

HONEYWELL

**DPS/LEVEL 68 &
DPS 8M
MULTICS
PROCESSOR
MANUAL**

HARDWARE

DPS/LEVEL 68)
& DPS 8M
MULTICS PROCESSOR MANUAL

SUBJECT

Description of the Multics Processor

SPECIAL INSTRUCTIONS

This manual supersedes AL39, Revision 0, dated April 1976 and AL39A, Revision 0, dated September 1976. The manual has been extensively revised. Change bars in the margin indicate technical additions and changes; asterisks denote deletions.

ORDER NUMBER

AL39, Rev. 1

April 1979

Honeywell

PREFACE

This manual describes the processors used in the Multics system. These are the DPS/L68, which refers to the DPS, L68 or older model processors (excluding the GE-645) and DPS 8M, which refers to the DPS 8 family of Multics processors, i.e. DPS 8/70M, DPS 8/62M and DPS 8/52M. The reader should be familiar with the overall modular organization of the Multics system and with the philosophy of asynchronous operation. In addition, this manual presents a discussion of virtual memory addressing concepts including segmentation and paging.

The manual is intended for use by systems programmers responsible for writing software to interface with the virtual memory hardware and with the fault and interrupt portions of the hardware. It should also prove valuable to programmers who must use machine instructions (particularly language translator implementors) and to those persons responsible for analyzing crash conditions in system dumps.

This manual includes the processor capabilities, modes of operation, functions, and detailed descriptions of machine instructions. Data representation, program-addressable registers, addressing by means of segmentation and paging, faults and interrupts, hardware ring implementation, and cache operation are also covered.

Changes and Additions

Section 3 has been revised to include register information pertaining to the DPS 8M processor.

The information and specifications in this document are subject to change without notice. This document contains information about Honeywell products or services that may not be available outside the United States. Consult your Honeywell Marketing Representative.

CONTENTS

		Page
Section 1	Introduction	1-1
	Multics Processor Features	1-1
	Segmentation and Paging	1-2
	Address Modification and Address Appending	1-2
	Faults and Interrupts	1-2
	Processor Modes of Operation	1-3
	Instruction Execution Modes	1-3
	Normal Mode	1-3
	Privileged Mode	1-3
	Addressing Modes	1-3
	Absolute Mode	1-3
	Append Mode	1-4
	Bar Mode	1-4
	Processor Unit Functions	1-4
	Appending Unit	1-4
	Associative Memory Assembly	1-4
	Control Unit	1-4
	Operation Unit	1-5
	Decimal Unit	1-5
	Section 2	Data Representation
Information Organization		2-1
Position Numbering		2-1
Number System		2-1
Information Formats		2-2
Data Parity		2-4
Representation of Data		2-4
Numeric Data		2-4
Fixed-point Binary Data		2-4
Fixed-Point Binary Integers		2-4
Fixed-point Binary Fractions		2-5
Floating-point Binary Data		2-6
Overlength Registers		2-8
Normalized Numbers		2-8
Decimal Data		2-9
Decimal Data Values		2-11
Alphanumeric Data		2-12
Character String Data	2-12	
Bit String Data	2-12	
Section 3	Program Accessible Registers	3-1
	Accumulator Register (A)	3-2
	Quotient Register (Q)	3-3
	Accumulator-Quotient Register (AQ)	3-3
	Exponent Register (E)	3-4
	Exponent-Accumulator-Quotient Register (EAQ)	3-4
	Index Registers (X _n)	3-5
	Indicator Register (IR)	3-5
	Base Address Register (BAR)	3-9
	Timer Register (TR)	3-10
	Ring Alarm Register (RALR)	3-10
	Pointer Registers (PR _n)	3-11
	Address Registers (AR _n)	3-12
	Procedure Pointer Register (PPR)	3-14
Temporary Pointer Register (TPR)	3-15	
Descriptor Segment Base Register (DSBR)	3-16	

CONTENTS (cont)

	Page
Segment Descriptor Word Associative Memory (SDWAM) - DPS/L68 and DPS 8M	3-18
Page Table Word Associative Memory (PTWAM) - DPS/L68 and DPS 8M	3-20
Fault Register (FR) - DPS/L68	3-23
Fault Register (FR) - DPS 8M	3-25
Mode Register (MR) - DPS and L68	3-27
Mode Register (MR) - DPS 8M	3-30
Cache Mode Register (CMR) - DPS and L68	3-32
Cache Mode Register (CMR) - DPS 8M	3-34
Control Unit (CU) History Registers - DPS and L68	3-37
Control Unit (CU) History Registers - DPS 8M	3-39
Operations Unit (OU) History Registers	3-41
Decimal Unit (DU) History Registers - DPS and L68	3-43
Decimal/Operations Unit (DU/OU) History Registers - DPS 8M	3-46
Appending Unit (APU) History Registers - DPS and L68	3-49
Appending Unit (APU) History Registers - DPS 8M	3-51
Configuration Switch Data - DPS and L68	3-54
Configuration Switch Data - DPS 8M	3-56
Control Unit Data	3-58
Decimal Unit Data	3-63

Section 4

Machine Instructions	4-1
Instruction Repertoire	4-1
Arrangement of Instructions	4-1
Basic Operations	4-1
Extended Instruction Set (eis) Operations	4-1
EIS Single-Word Operations	4-2
EIS Multiword Operations	4-2
Format of Instruction Description	4-2
Definitions of Notation and Symbols	4-4
Main Memory Addresses	4-4
Index Values	4-4
Abbreviations and Symbols	4-4
Register Positions and Contents	4-5
Other Symbols	4-5
Common Attributes of Instructions	4-6
Illegal Modification	4-6
Parity Indicator	4-6
Instruction Word Formats	4-6
Basic and EIS Single-Word Instructions	4-6
Indirect Words	4-7
EIS Multiword Instructions	4-8
EIS Modification Fields (MF)	4-9
MF Coding Examples	4-11
EIS Operand Descriptors and Indirect Pointers	4-11
Operand Descriptor Indirect Pointer	4-11.1
Format	4-11.1
Alphanumeric Operand Descriptor Format	4-12
Numeric Operand Descriptor Format	4-13
Bit-string Operand Descriptor Format	4-15
Fixed-point Arithmetic Instructions	4-16
Fixed-Point Data Movement Load	4-16
Fixed-Point Data Movement Store	4-25
Fixed-Point Data Movement Shift	4-36
Fixed-Point Addition	4-42
Fixed-Point Subtraction	4-50
Fixed-Point Multiplication	4-57
Fixed-Point Division	4-59

CONTENTS (cont)

	Page
Fixed-Point Negate	4-62
Fixed-Point Comparison	4-64
Fixed-Point Miscellaneous	4-69
Boolean Operation Instructions	4-70
Boolean AND	4-70
Boolean Or	4-74
Boolean Exclusive Or	4-78
Boolean Comparative And	4-82
Boolean Comparative Not	4-84
Floating-Point Arithmetic Instructions	4-86
Floating-Point Data Movement Load	4-86
Floating-Point Data Movement Store	4-87
Floating-Point Addition	4-90
Floating-Point Subtraction	4-93
Floating-Point Multiplication	4-96
Floating-Point Division	4-99
Floating-Point Negate	4-103
Floating-Point Normalize	4-104
Floating-Point Round	4-105
Floating-Point Compare	4-107
Floating-Point Miscellaneous	4-109
Transfer Instructions	4-111
Pointer Register Instructions	4-124
Pointer Register Data Movement Load	4-124
Pointer Register Data Movement Store	4-130
Pointer Register Address Arithmetic	4-134
Pointer Register Miscellaneous	4-135
Miscellaneous Instructions	4-136
Calendar Clock	4-136
Derail	4-137
Execute	4-138
Master Mode Entry	4-140
No Operation	4-143
Repeat	4-145
Ring Alarm Register	4-153
Store Base Address Register	4-154
Translation	4-155
Register Load	4-157
Privileged Instructions	4-157.1
Privileged - Register Load	4-157.1
Privileged - Register Store	4-163
Privileged - Clear Associative Memory	4-168
Privileged - Configuration and Status	4-170
Privileged - System Control	4-173
Privileged - Miscellaneous	4-176
Extended Instruction Set (EIS)	4-177
EIS - Address Register Load	4-177
EIS - Address Register Store	4-180
EIS - Address Register Special Arithmetic	4-183
EIS - Alphanumeric Compare	4-191
EIS - Alphanumeric Move	4-202
EIS - Numeric Compare	4-210
EIS - Numeric Move	4-213
EIS - Bit String Combine	4-218
EIS - Bit String Compare	4-222
EIS - Bit String Set Indicators	4-224
EIS - Data Conversion	4-226
EIS - Decimal Addition	4-230
EIS - Decimal Subtraction	4-236
EIS - Decimal Multiplication	4-239
EIS - Decimal Division	4-242
Micro Operations For Edit Instructions	4-246
Micro Operation Sequence	4-246
Edit Insertion Table	4-246
Edit Flags	4-247

CONTENTS (cont)

	Page
Terminating Micro Operations	4-247
MVNE and MVE Differences	4-248
Numeric Edit	4-248
Alphanumeric Edit	4-248
Micro Operations	4-248
Micro Operation Code Assignment Map	4-257
 Section 5	
Addressing -- Segmentation And Paging	5-1
Addressing Modes	5-1
Absolute Mode	5-1
Append Mode	5-2
Segmentation	5-2
Paging	5-3
Changing Addressing Modes	5-5
Address Appending	5-6
Address Appending Sequences	5-6
Appending Unit Data Word Formats	5-9
Page Table Word (ptw) Format	5-10
 Section 6	
Virtual Address Formation	6-1
Definition of Virtual Address	6-1
Types of Virtual Address Formation	6-1
Symbology (alm)	6-2
Symbolic Fields	6-2
Alm Pseudo-Instructions	6-2
Computed Address Formation	6-3
The Address Modifier (TAG) Field	6-3
General Types of Computed Address Modification	6-4
Computed Address Formation Flowcharts	6-6
Register (r) Modification	6-6
Examples:	6-8
Register Then Indirect (ri) Modifications Examples:	6-9 6-10
Indirect Then Register (ir) Modification Examples:	6-10 6-11
Indirect Then Tally (it) Modification	6-12
Special Address Modifiers	6-19
Indirect to Pointer (ITP) Modification	6-20
Indirect to Segment (ITS) Modification	6-21
Effective Segment Number Generation	6-22
Virtual Address Formation for Extended Instruction Set	6-24
Character- and Bit-String Addressing	6-26
Character- and Bit-String Address Arithmetic Algorithms	6-26
9-bit Byte String Address Arithmetic	6-27
6-bit Character String Address Arithmetic	6-27
4-bit Byte String Address Arithmetic	6-27
Bit String Address Arithmetic	6-27
 Section 7	
Faults And Interrupts	7-1
Fault Cycle Sequence	7-1
Fault Priority	7-3
Fault Recognition	7-4
Fault Descriptions	7-4
Group 1 Faults	7-4
Group 2 Faults	7-5
Group 3 Faults	7-5
Group 4 Faults	7-6
Group 5 Faults	7-7
Group 6 Faults	7-7

CONTENTS (cont)

		Page
	Group 7 Faults	7-8
	Interrupts and External Faults	7-8
	Interrupt Sampling	7-8
	Interrupt Cycle Sequence	7-9
Section 8	Hardware Ring Implementation	8-1
	Ring Protection in Multics	8-1
	Ring Protection in the Processor	8-2
	Appending Unit Operation with Ring Mechanism	8-3
Section 9	Cache Memory Operation	9-1
	Philosophy of Cache Memory	9-1
	Cache Memory Organization	9-1
	Cache Memory/Main Memory Mapping	9-1
	Cache Memory Addressing	9-4
	Cache Memory Control	9-5
	Enabling and Disabling Cache Memory	9-5
	Cache Memory Control in Segment	
	Descriptor Words	9-6
	Loading the Cache Memory	9-6
	Clearing the Cache Memory	9-6
	General Clear	9-6
	Selective Clear	9-7
	Dumping the Cache Memory	9-7
Appendix A	Operation Code Map	A-1
Appendix B	Alphabetic Operation Code List	B-1
Appendix C	Address Modifiers	C-1
	Nonstandard Modifiers	C-1
Index	i-1

ILLUSTRATIONS

Figure 2-1.	Unstructured Machine Word Format	2-2
Figure 2-2.	Unstructured Word Pair Format	2-3
Figure 2-3.	Unstructured 4-bit Byte Format	2-3
Figure 2-4.	Unstructured 6-bit Character Format	2-3
Figure 2-5.	Unstructured 9-bit Byte Format	2-3
Figure 2-6.	Unstructured 18-bit Half Word Format	2-4
Figure 2-7.	Eighteen-bit Half Word Floating-Point Binary Operand Format	2-7
Figure 2-8.	Single-Precision Floating-Point Binary Operand Format	2-7
Figure 2-9.	Double-Precision Floating-Point Binary Operand Format	2-7
Figure 3-1.	Accumulator Register (A) Format	3-2
Figure 3-2.	Quotient Register (Q) Format	3-3
Figure 3-3.	Accumulator-Quotient Register (AQ) Format	3-3
Figure 3-4.	Exponent Register (E) Format	3-4
Figure 3-5.	Exponent-Accumulator-Quotient Register (EAQ) Format	3-4
Figure 3-6.	Index Register (X _n) Format	3-5
Figure 3-7.	Indicator Register (IR) Format	3-5
Figure 3-8.	Base Address Register (BAR) Format	3-9
Figure 3-9.	Timer Register (TR) Format	3-10
Figure 3-10.	Ring Alarm Register (RALR) Format	3-10
Figure 3-11.	Pointer Register (PR _n) Format	3-11
Figure 3-12.	Address Register (AR _n) Format	3-12
Figure 3-13.	Procedure Pointer Register (PPR) Format	3-14

CONTENTS (cont)

	Page
Figure 3-14.	Temporary Pointer Register (TPR) Format 3-15
Figure 3-15.	Descriptor Segment Base Register (DSBR) Format 3-16
Figure 3-16.	Segment Descriptor Word Associative Memory (SDWAM) Format DPS/L68 and DPS 8M 3-18
Figure 3-17.	Page Table Word Associative Memory (PTWAM) Format DPS/L68 and DPS 8M 3-20
Figure 3-18.	Fault Register (FR) Format - DPS and L68 3-23
Figure 3-19.	Fault Register (FR) Format - DPS 8M 3-25
Figure 3-20.	Mode Register (MR) Format - DPS and L68 3-27
Figure 3-21.	Mode Register (MR) Format - DPS 8M 3-30
Figure 3-22.	Cache Mode Register (CMR) Format - DPS and L68 3-32
Figure 3-23.	Cache Mode Register (CMR) Format - DPS 8M 3-34
Figure 3-24.	Control Unit (CU) History Register Format - DPS and L68 3-37
Figure 3-25.	Control Unit (CU) History Register Format - DPS 8M 3-39
Figure 3-26.	Operations Unit (OU) History Register Format 3-41
Figure 3-27.	Decimal/Operations (DU/OU) History Register Format - DPS 8M 3-46
Figure 3-28.	Appending Unit (APU) History Register Format - DPS and L68 3-49
Figure 3-29.	Appending Unit (APU) History Register Format - DPS 8M 3-51
Figure 3-30.	Configuration Switch Data Formats - DPS and L68 3-54
Figure 3-31.	Configuration Switch Data Formats - DPS 8M 3-56
Figure 3-32.	Control Unit Data Format 3-58
Figure 3-33.	Decimal Unit Data Format 3-63
Figure 4-1.	Basic and EIS Single-Word Instruction Format 4-7
Figure 4-2.	Indirect Word Format 4-8
Figure 4-3.	EIS Multiword Instruction Format 4-9
Figure 4-4.	EIS Modification Field (MF) Format 4-9
Figure 4-5.	Operand Descriptor Indirect Pointer Format 4-11.1
Figure 4-6.	Alphanumeric Operand Descriptor Format 4-12
Figure 4-7.	Numeric Operand Descriptor Format 4-14
Figure 4-8.	Bit String Operand Descriptor Format 4-15
Figure 4-9.	Repeat Double (rpd) Instruction Word Format 4-145
Figure 4-10.	Repeat Link (rpl) Instruction Word Format 4-148
Figure 4-11.	Repeat (rpt) Instruction Word Format 4-150
Figure 4-12.	EIS Address Register Special Arithmetic Instruction Format 4-183
Figure 4-13.	Compare Alphanumeric Character Strings (cmpe) EIS Multiword Instruction Format 4-191
Figure 4-14.	Scan Characters Double (scd) EIS Multiword Instruction Format 4-193
Figure 4-15.	Scan with Mask (scm) EIS Multiword Instruction Format 4-196
Figure 4-16.	Test Character and Translate (tct) EIS Multiword Instruction Format 4-199
Figure 4-17.	Move Alphanumeric Left to Right (mlr) EIS Multiword Instruction Format 4-202
Figure 4-18.	Move Alphanumeric Edited (mve) EIS Multiword Instruction Format 4-205
Figure 4-19.	Move Alphanumeric with Translation (mvt) EIS Multiword Instruction Format 4-207
Figure 4-20.	Compare Numeric (cmpn) EIS Multiword Instruction Format 4-210
Figure 4-21.	Move Numeric (mvn) EIS Multiword Instruction Format 4-213
Figure 4-22.	Move Numeric Edited (mvne) EIS Multiword Instruction Format 4-216
Figure 4-23.	Combine Bit Strings Left (csl) EIS Multiword Instruction Format 4-218
Figure 4-24.	Compare Bit Strings (cmpb) EIS Multiword Instruction Format 4-222

CONTENTS (cont)

	Page
Figure 4-25.	Binary to Decimal Convert (BTD) EIS Multiword Instruction Format 4-226
Figure 4-26.	Decimal to Binary Convert (dtb) EIS Multiword Instruction Format 4-228
Figure 4-27.	Add Using Two Decimal Operands (ad2d) EIS Multiword Instruction Format 4-230
Figure 4-28.	Add Using Three Decimal Operands (ad3d) EIS Multiword Instruction Format 4-233
Figure 4-29.	Micro Operation (MOP) Character Format 4-246
Figure 5-1.	Main Memory Address Generation for Unpaged Segments 5-3
Figure 5-2.	Page Number Formation 5-3
Figure 5-3.	Main Memory Address Generation for Paged Segments 5-5
Figure 5-4.	Appending Unit Operation Flowchart 5-8
Figure 5-5.	Segment Descriptor Word (SDW) Format 5-9
Figure 5-6.	Page Table Word (PTW) Format 5-10
Figure 6-1.	Address Modifier (TAG) Field Format 6-3
Figure 6-2.	Common Computed Address Formation Flowchart 6-6
Figure 6-3.	Register Modification Flowchart 6-7
Figure 6-4.	Register Then Indirect Modification Flowchart 6-9
Figure 6-5.	Indirect Then Register Modification Flowchart 6-11
Figure 6-6.	Indirect Then Tally Modification Flowchart 6-18
Figure 6-7.	Format of Instruction Word ADDRESS When Bit 29 = 1 6-19
Figure 6-8.	ITP Pointer Pair Format 6-21
Figure 6-9.	ITS Pointer Pair Format 6-22
Figure 6-10.	Effective Segment Generation Flowchart 6-23
Figure 6-11.	EIS Virtual Address Formation Flowchart 6-25
Figure 8-1.	Complete Appending Unit Operation Flowchart 8-4
Figure 9-1.	Main Memory/Cache Memory Mapping 9-3
Figure A-1.	Processor Operation Code Map A-2
Figure A-2.	EIS MF Codes A-4

TABLES

Table 2-1.	Fixed-Point Binary Integer Values 2-5
Table 2-2.	Fixed-Point Binary Fraction Values 2-6
Table 2-3.	Floating-Point Binary Operand Values 2-9
Table 2-4.	Decimal Sign Character Interpretation 2-10
Table 2-5.	Decimal Data Values 2-11
Table 2-6.	Character String Data Length Limits 2-12
Table 3-1.	Processor Registers 3-1
Table 3-2.	System Controller Illegal Action Codes 3-25
Table 4-1.	R-type Modifiers for REG Fields 4-10
Table 4-2.	Alphanumeric Character Number (CN) Codes 4-13
Table 4-3.	Alphanumeric Data Type (TA) Codes 4-13
Table 4-4.	Sign and Decimal Type (S) Codes 4-14
Table 4-5.	Relation Between Data Bits and Indicators 4-22
Table 4-6.	Control Relations for Store Byte Instructions (9-Bit) 4-28
Table 4-7.	Control Relations for Store Character Instructions (6-Bit) 4-31
Table 4-8.	Default Edit Insertion Table Characters 4-247
Table 4-9.	Micro Operation Code Assignment Map 4-257
Table 5-1.	Appending Unit Cycle Definitions 5-7
Table 6-1.	General Computed Address Modification Types 6-5
Table 6-2.	Register Modification Decode 6-8
Table 6-3.	Variations of Indirect Then Tally Modification 6-13
Table 6-4.	Special Address Modifiers 6-20
Table 7-1.	List of Faults 7-3

SECTION 1

INTRODUCTION

The processor described in this reference manual is a hardware module designed for use with Multics. The many distinctive features and functions of Multics are enhanced by the powerful hardware features of the processor. The addressing features, in particular, are designed to permit the Multics software to compute relative and absolute addresses, locate data and programs in the Multics virtual memory, and retrieve such data and programs as necessary.

MULTICS PROCESSOR FEATURES

The Multics processor contains the following general features:

1. Storage protection to place access restrictions on specified segments.
2. Capability to interrupt program execution in response to an external signal (e.g., I/O termination) at the end of any even/odd instruction pair (midinstruction interrupts are permitted for some instructions), to save processor status, and to restore the status at a later time without loss of continuity of the program.
3. Capability to fetch instruction pairs and to buffer two instructions (up to four instructions, depending on certain main memory overlap conditions) including the one currently in execution.
4. Overlapping instruction execution, address preparation, and instruction fetch. While an instruction is being executed, address preparation for the next operand (or even the operand following it) or the next instruction pair is taking place. The operations unit can be executing instruction N, instruction N+1 can be buffered in the operations unit (with its operand buffered in a main memory port), and the control unit can be executing instructions N+2 or N+3 (if such execution does not involve the main memory port or registers of instructions N or N+1) or preparing the address to fetch instructions N+4 and N+5. This includes the capability to detect store instructions that alter the contents of buffered instructions and the ability to delay preprocessing of an address using register modification if the instruction currently in execution changes the register to be used in that modification.
5. Interlacing capability to direct main memory accesses to interlaced system controller modules.
6. Intermediate storage of address and control information in high-speed registers addressable by content (associative memory).
7. Intermediate storage of base address and control information in pointer registers that are loaded by the executing program.
8. Absolute address computation at execution time.

9. Ability to hold recently referenced operands and instructions in a high-speed look-aside memory (cache option).

Segmentation and Paging

A segment is a collection of data or instructions that is assigned a symbolic name and addressed symbolically by the user. Paging is controlled by the system software; the user need not be aware of the existence of pages. User-visible address preparation is concerned with the calculation of a virtual memory address; the processor hardware completes address preparation by translating the final virtual memory address into an absolute main memory address. The user may view each of his segments as residing in an independent main memory unit. Each segment has its own origin that can be addressed as location zero. The size of each segment varies without affecting the addressing of the other segments. Each segment can be addressed like a conventional main memory image starting at location zero. Maximum segment size is 262,144 words.

When viewed from the processor, main memory consists of blocks or page frames, each of which has a length of "page-size" words. The page size used by Multics is 1024 words. Each frame begins at an absolute address which is zero modulo the page size. Any page of a segment can be placed in any available main memory frame. These pages may be addressed as if they were contiguous, even though they may be in widely scattered absolute locations. Only currently referenced pages need be in main memory. A segment need not be paged, in which case the complete segment is located in contiguous words of main memory. In Multics, all user segments are paged. See Section 5 for additional discussion.

Address Modification and Address Appending

Before each main memory access, two major phases of address preparation take place:

1. Address modification by register or indirect word content, if specified by the instruction word or indirect word.
2. Address appending, in which a virtual memory address is translated into an absolute address to access main memory.

Although the above two types of modification are combined in most operations, they are described separately in Sections 5 and 6. The address modification procedure can go on indefinitely, with one type of modification leading to repetitions of the same type or to other types of modification prior to a main memory access for an operand.

Faults and Interrupts

The processor detects certain illegal instruction usages, faulty communication with the main memory, programmed faults, certain external events, and arithmetic faults. Many of the processor fault conditions are deliberately or inadvertently caused by the software and do not necessarily involve error conditions. The processor communicates with the other system modules (I/O multiplexers, bulk store controllers, and other processors) by setting and answering external interrupts. When a fault or interrupt is recognized, a "trap" results. The trap causes the forced execution of a pair of instructions in a main memory location, unique to the fault or interrupt, known as the fault or interrupt vector. The first of the forced instructions may cause safe storage of the processor status. The second instruction in a fault vector

should be some form of transfer, or the faulting program will be resumed at the point of interruption. Faults and interrupts are described in Section 7.

Interrupts and certain low-priority faults are recognized only at specific times during the execution of an instruction pair. If, at these times, bit 28 in the instruction word is set ON, the trap is inhibited and program execution continues. The interrupt or fault signal is saved for future recognition and is reset only when the trap occurs.

PROCESSOR MODES OF OPERATION

There are three modes of main memory addressing (absolute mode, append mode, and BAR mode), and two modes of instruction execution (normal mode and privileged mode).

Instruction Execution Modes

NORMAL MODE

Most instructions can be executed in the normal mode. Certain instructions, classed as privileged, cannot be executed in normal mode. These are identified in the individual instruction descriptions. An attempt to execute privileged instructions while in the normal mode results in an illegal procedure fault. The processor executes instructions in normal mode only if it is forming addresses in append mode and the segment descriptor word (SDW) for the executing segment specifies a nonprivileged procedure.

PRIVILEGED MODE

In privileged mode, all instructions can be executed. The processor executes instructions in privileged mode when forming addresses in absolute mode or when forming addresses in append mode and the segment descriptor word (SDW) for the segment in execution specifies a privileged procedure and the execution ring is equal to zero. See Sections 5 and 7 for additional discussion.

Addressing Modes

ABSOLUTE MODE

In absolute mode, the final computed address is treated as the absolute main memory address unless the appending hardware mechanism is invoked for a particular main memory reference. During instruction fetches, the procedure pointer register is ignored. The processor enters absolute mode when it is initialized or immediately after a fault or interrupt. It remains in absolute mode until it executes a transfer instruction whose operand is obtained via explicit use of the appending hardware mechanism.

The appending hardware mechanism may be invoked for an instruction by setting bit 29 of the instruction word ON to cause a reference to a properly loaded pointer register or by the use of indirect-to-segment (its) or indirect-to-pointer (itp) modification in an indirect word.

APPEND MODE

The append mode is the most commonly used main memory addressing mode. In append mode the final computed address is either combined with the procedure pointer register, or it is combined with one of the eight pointer registers. If bit 29 of the instruction word contains a 0, then the procedure pointer register is selected; otherwise, the pointer register given by bits 0-2 of the instruction word is selected.

BAR MODE

In BAR mode, the base address register (BAR) is used. The BAR contains an address bound and a base address. All computed addresses are relocated by adding the base address. The relocated address is combined with the procedure pointer register to form the virtual memory address. A program is kept within certain limits by subtracting the unrelocated computed address from the address bound. If the result is zero or negative, the relocated address is out of range, and a store fault occurs.

PROCESSOR UNIT FUNCTIONS

Major functions of each principal logic element are listed below and are described in subsequent sections of this manual.

Appending Unit

- Controls data input/output to main memory
- Performs main memory selection and interlace
- Does address appending
- Controls fault recognition
- Interfaces with cache

Associative Memory Assembly

This assembly consists of sixteen 51-bit page table word associative memory (PTWAM) registers and sixteen 108-bit segment descriptor word associative memory (SDWAM) registers. These registers are used to hold pointers to most recently used segments (SDWs) and pages (PTWs). This unit reduces the need for possible multiple main memory accesses before obtaining an absolute main memory address of an operand or instruction.

Control Unit

- Performs address modification
- Controls mode of operation (privileged, normal, etc.)
- Performs interrupt recognition

Decodes instruction words and indirect words
Performs timer register loading and decrementing

Operation Unit

Does fixed- and floating-binary arithmetic
Does shifting and Boolean operations

Decimal Unit

Does decimal arithmetic
Does character-string and bit-string operations

SECTION 2

DATA REPRESENTATION

INFORMATION ORGANIZATION

The processor, like the rest of the Multics system, is organized to deal with information in basic units of 36-bit words. Other units of 4-, 6-, 9-bit characters or bytes, 18-bit half words, and 72-bit word pairs can be manipulated within the processor by use of the instruction set. These bit groupings are used by the hardware and software to represent a variety of forms of coded data. Certain processor functions appear to manipulate larger units of 144, 288, 576, and 1152 bits, but these functions are performed by means of repeated use of 72-bit word pairs. All information is transmitted, stored, and processed as strings of binary bits. The data values are derived when the bit strings are interpreted according to the various formats discussed in this section.

POSITION NUMBERING

The numbering of bit positions, character and byte positions, and words increases from 0 in the direction of conventional reading and writing: from the most significant to the least significant digit of a number, and from left to right in conventional alphanumeric text.

Graphic presentations in this manual show registers and data with position numbers increasing from left to right.

NUMBER SYSTEM

The binary arithmetic functions of the processor are implemented in the two's complement, binary number system. One of the primary properties of this number system is that a field (or register) having width n bits may be interpreted in two different ways; the logical case and the arithmetic or algebraic case.

In the logical case, the number is unsigned, positive, and lies in the range $[0, 2^n - 1]$ where n is the size of the register or the length of the field. The results of arithmetic operations on numbers for this case are interpreted as modulo 2^n numbers. Overflow is not defined for this case since the range of the field or register cannot be exceeded. The numbers 0 and $2^n - 1$ are consecutive (not separated) in the set of numbers defined for the field or register.

In the arithmetic case, the number is signed and lies in the range $[-2^{(n-1)}, 2^{(n-1)} - 1]$. Overflow is defined for this case since the range can be exceeded in either direction (positive or negative). The left-hand-most bit of the field or register (bit 0) serves as the sign bit and does not contribute to the magnitude of the number.

The main advantage of this implementation is that the hardware arithmetic algorithms for the two cases are identical; the only distinction lying in the interpretation of the results by the user. Instruction set features are provided for performing binary arithmetic with overflow disabled (the so-called logical instructions) and for comparing numbers in either sense.

Subtraction is performed by adding the twos complement of the subtrahend to the minuend. (Note that when the subtrahend is zero the algorithm for forming the twos complement is still carried out, but, since the twos complement of zero is zero, the result is correct.)

Another important feature of the twos complement number system (with respect to comparison of numeric values) is that the no borrow condition in true subtraction is identical to the carry condition in true addition and vice versa.

A statement on the assumed location of the binary point has significance only for multiplication and division. These two operations are implemented for the arithmetic case in both integer and fraction modes. Integer means that the position of the binary point is assumed to the right of the least significant bit position, that is, to the right of the right-hand-most bit of the field or register, and fraction means that the position of the binary point is assumed to the left of the most significant bit position, that is, between bit 0 and bit 1 of the field or register (recall that bit 0 is the sign bit).

INFORMATION FORMATS

The figures that follow show the unstructured formats (templates) for the various information units defined for the processor. Data transfer between the processor and main memory is word oriented; a 36-bit machine word is transferred for single-precision operands and subfields of machine words, and a 72-bit word pair is transferred for all other cases (multiword operands, instruction fetches, bit- and character-string operands, etc.). The information unit to be used and the data transfer mode are determined by the processor according to the function to be performed.

The 36-bit unstructured machine word shown in Figure 2-1 is the minimum addressable information unit in main memory. Its location is uniquely determined by its main memory address, Y. All other information units are defined relative to the 36-bit machine word.

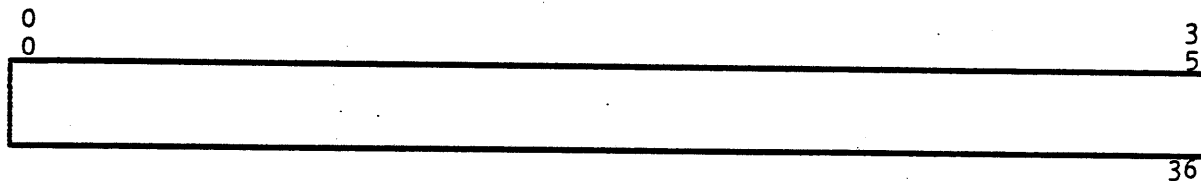

Figure 2-1. Unstructured Machine Word Format

Two consecutive machine words as shown in Figure 2-2, the first having an even main memory address, form a 72-bit word pair. In 72-bit word pair data transfer mode, the word pair is uniquely located by the main memory address of either of its constituent 36-bit machine words. Thus, if Y is even, the word pair at (Y, Y+1) is selected. If Y is odd, the word pair at (Y-1, Y) is selected. The term Y-pair is used when referring to such a word pair.

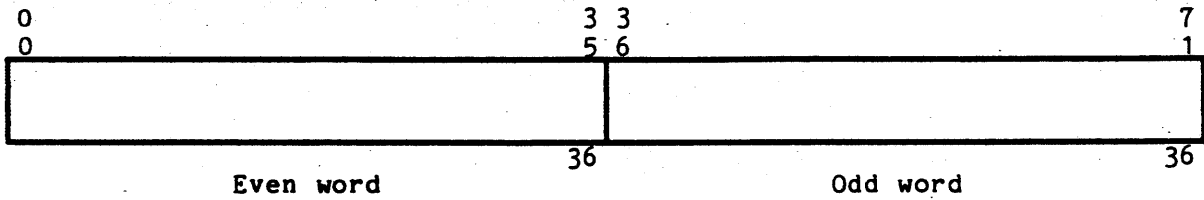

Figure 2-2. Unstructured Word Pair Format

Four-bit bytes are mapped onto 36-bit machine words as shown in Figure 2-3. The 0 bits at bit positions 0, 9, 18, and 27 are forced to be 0 by the processor on data transfers to main memory and are ignored on data transfers from main memory.

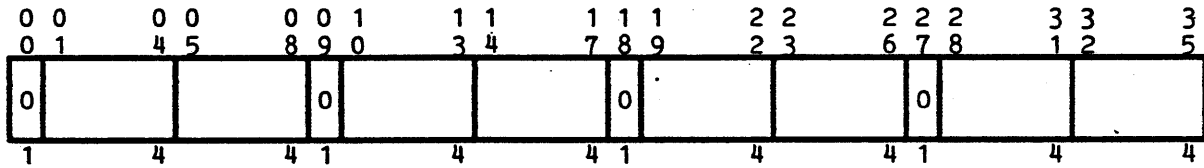

Figure 2-3. Unstructured 4-bit Byte Format

Six-bit characters are mapped onto 36-bit machine words as shown in Figure 2-4.

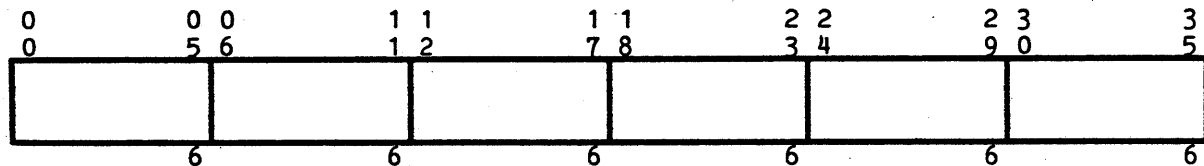

Figure 2-4. Unstructured 6-bit Character Format

Nine-bit bytes are mapped onto 36-bit machine words as shown in Figure 2-5.

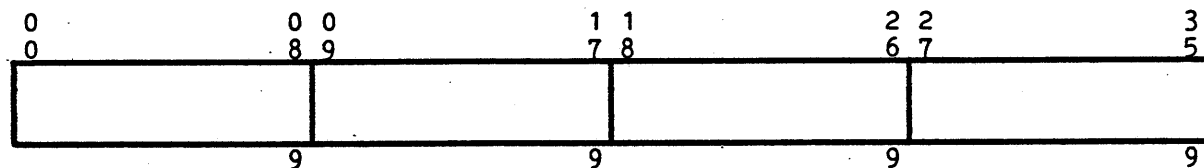

Figure 2-5. Unstructured 9-bit Byte Format

Eighteen-bit half words are mapped onto 36-bit machine words as shown in Figure 2-6.

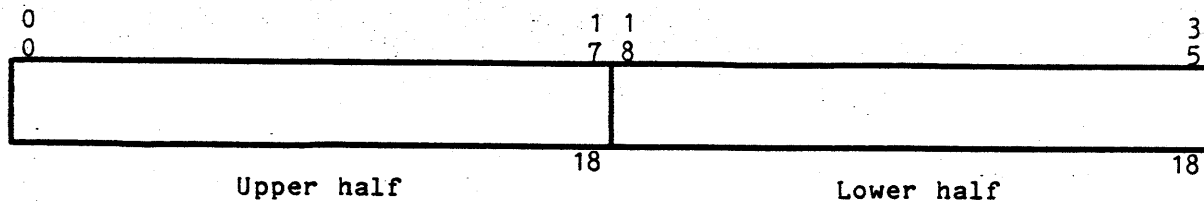

Figure 2-6. Unstructured 18-bit Half Word Format

DATA PARITY

Odd parity on each 36-bit machine word transferred to main memory is generated as it leaves the processor, is verified at several points along the transmission path, and is held in main memory either as an extra bit in the case of magnetic core memory or as part of the error detecting and correcting (EDAC) code in the case of magnetic oxide semiconductor (MOS) memory. If an incorrect parity is detected at any of the various parity check points, the main memory returns an illegal action signal and a code appropriate to the check point.

On data transfers from main memory, the parity information is retrieved and transmitted with the data information. The same verification checks are made and illegal action signalled for errors. The processor makes a final parity check as the data enters the processor.

Any detected parity error causes the processor parity indicator to be set ON and (if enabled) a parity fault occurs.

REPRESENTATION OF DATA

Data is defined by imposing an operand structure on the information units just described. Data is represented in two forms: numeric or alphanumeric. The form is determined by the processor according to function to be performed.

In the definitions below, a_i is the value of the bit in the i^{th} bit position, either 0 or 1.

Numeric Data

Numeric data is represented in three modes: fixed-point binary, floating-point binary, and decimal. The mode is determined by the processor according to the function being performed.

FIXED-POINT BINARY DATA

Fixed-Point Binary Integers

Fixed-point binary integer data is defined by imposing either of the bit position value expressions shown below on an information unit of n bits.

Logical value:

$$a_0x2^{(n-1)} + a_1x2^{(n-2)} + \dots + a_ix2^{(n-i-1)} + \dots + a_{n-1}$$

Arithmetic value:

$$-a_0x2^{(n-1)} + a_1x2^{(n-2)} + \dots + a_ix2^{(n-i-1)} + \dots + a_{n-1}$$

The following fixed-point binary integer data items are defined (also see Table 2-1 for values):

<u>Operand size(bits)</u>	<u>Operand name</u>
6	6-bit character operand
9	9-bit byte operand
18	Half word operand
36	Single-precision operand
72	Double-precision operand

Note that a 4-bit operand is not defined. This data item is defined only for decimal data. (See discussion of decimal data later in this section).

The proper operand and its position with respect to a 36-bit machine word are determined by the processor during preparation of the main memory address for the operand. If the data width of the operand selected is smaller than the register involved, the operand is high- or low-order zero filled as necessary.

The values in Table 2-1 are given in terms of the operand sizes. The value an operand contributes to a larger field or register depends on the alignment of the operand with respect to the field or register.

Table 2-1. Fixed-Point Binary Integer Values

Operand	6-bit character	9-bit byte	18-bit half word	36-bit single precision	72-bit double precision
Logical					
minimum	2^0	2^0	2^0	2^0	2^0
maximum	2^6-1	2^9-1	$2^{18}-1$	$2^{36}-1$	$2^{72}-1$
resolution	1	1	1	1	1
Arithmetic					
minimum	0	0	0	0	0
maxima					
negative	2^5	2^8	2^{17}	2^{35}	2^{71}
positive	2^5-1	2^8-1	$2^{17}-1$	$2^{35}-1$	$2^{71}-1$
resolution	1	1	1	1	1

Fixed-point Binary Fractions

Fixed-point binary fraction data is defined by imposing the bit position value expression below on an information unit of n bits.

Arithmetic value:

$$-a_0 + a_1x2^{-1} + a_2x2^{-2} + \dots + a_ix2^{-i} \dots + a_{n-1}x2^{-(n-1)}$$

Note that logical values are not defined for fixed-point binary fraction data.

The following fixed-point binary fraction data items are defined (also see Table 2-2 for values):

<u>Operand size(bits)</u>	<u>Operand name</u>
6	6-bit character operand
9	9-bit byte operand
18	Half word operand
36	Single-precision operand
72	Double-precision operand

Note that a 4-bit operand is not defined. This data item is defined only for decimal data. (See discussion of decimal data later in this section.) Fixed-point binary fraction operands are used by the Divide Fraction (dvf) and Multiply Fraction (mpf) instructions only.

The proper operand and its position with respect to a 36-bit machine word are determined by the processor during preparation of the main memory address for the operand. If the data width of the operand selected is smaller than the register involved, the operand is high- or low-order zero filled as necessary.

The values in Table 2-2 are given in terms of the operand sizes. The value an operand contributes to a larger field or register depends on the alignment of the operand with respect to the field or register.

Table 2-2. Fixed-Point Binary Fraction Values

Operand	6-bit character	9-bit byte	18-bit half word	36-bit single precision	72-bit double precision
Arithmetic minimum	0	0	0	0	0
Arithmetic maxima	-1.0	-1.0	-1.0	-1.0	-1.0
negative resolution	$1.0 \cdot 2^{-5}$	$1.0 \cdot 2^{-8}$	$1.0 \cdot 2^{-17}$	$1.0 \cdot 2^{-35}$	$1.0 \cdot 2^{-71}$
positive resolution	2^{-5}	2^{-8}	2^{-17}	2^{-35}	2^{-71}

FLOATING-POINT BINARY DATA

A floating-point binary number is expressed as:

$$Z = M \times 2^E$$

where:

M is a fixed-point binary fraction; the mantissa

E is a fixed-point binary integer; the exponent

A floating-point binary number is defined by partitioning an information unit of n bits into two pieces; an 8-bit fixed-point binary integer exponent and an (n-8)-bit fixed-point binary fraction mantissa.

The following floating-point data items are defined.

<u>Operand size(bits)</u>	<u>Operand name</u>
18	Half word operand
36	Single-precision operand
72	Double-precision operand

For clarity, the formats of these operands are shown in Figure 2-7 through Figure 2-9. In the figures, the fields labeled S hold sign bits associated with the exponent, E, and the mantissa, M.

The floating-point binary operands are used only by the floating-point binary arithmetic instructions (see Section 4). The 18-bit half word operand has meaning only when used in conjunction with the direct upper (du) address modification (see Section 6 for a discussion of address modification).

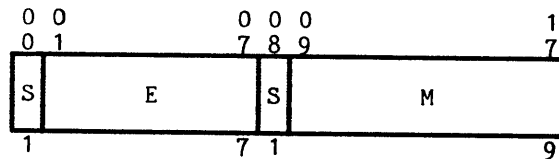

Figure 2-7. Eighteen-bit Half Word Floating-Point Binary Operand Format

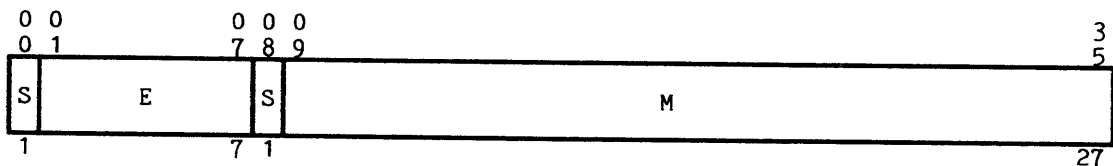

Figure 2-8. Single-Precision Floating-Point Binary Operand Format

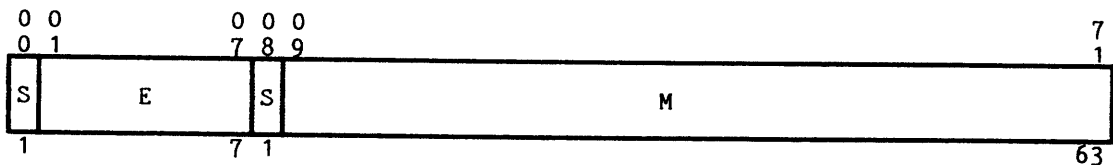

Figure 2-9. Double-Precision Floating-Point Binary Operand Format

The proper operand is selected by the processor during preparation of the main memory address for the operand.

Overlength Registers

The AQ-register is used to hold the mantissa of all floating-point binary numbers. The AQ-register is said to be overlength with respect to the operands since it has more bits than are provided by the operands. Operands are low-order zero filled when loaded and low-order truncated (or rounded, depending on the instruction) when stored. Thus, the result of all floating-point instructions has more bits of precision in the AQ-register than may be stored.

Users are cautioned that calculations involving floating-point operands may suffer from propagation of truncation errors even if the computation algorithms are designed to hold mantissas in the AQ-register as long as possible. It is possible to retain full AQ-register precision of intermediate results if they are saved with the Store AQ (staq) and Store Exponent (ste) instructions but such saved data are not usable as a floating-point operand.

Normalized Numbers

A floating-point binary number is said to be normalized if the relation

$$-0.5 > M > -1 \text{ or } 0.5 \leq M < 1 \text{ or } [M=0 \text{ and } E=-128]$$

is satisfied. This is a result of using a 2's complement mantissa. Bits 8 and 9 are different unless the number is zero. The presence of unnormalized numbers in any finite mantissa arithmetic can only degrade the accuracy of results. For example, in an arithmetic allowing only two digits in the mantissa, the number 0.005×10^2 has the value zero instead of the value one-half

Normalization is a process of shifting the mantissa and adjusting the exponent until the relation above is satisfied. Normalization may be used to recover some or all of the extra bits of the overlength AQ-register after a floating-point operation.

There are cases where the limits of the registers force the use of unnormalized numbers. For example, in an arithmetic allowing three digits of mantissa and one digit of exponent, the calculation $0.3 \times 10^{-10} - 0.1 \times 10^{-11}$ (the normalized case) may not be made, but $0.03 \times 10^{-9} - 0.001 \times 10^{-9} = 0.029 \times 10^{-9}$ (the unnormalized case) is a valid result.

Some examples of normalized and unnormalized floating-point binary numbers are:

Unnormalized positive binary 0.00011010×2^7

Same number normalized 0.11010000×2^4

Unnormalized negative binary 1.11010111×2^{-4}

Same number normalized 1.01011100×2^{-6}

The minimum normalized nonzero floating-point binary number is 2^{-128} in all cases. Table 2-3 gives the values for the floating-point binary operands.

Table 2-3. Floating-Point Binary Operand Values

Operand	18-bit half word	36-bit single precision	72-bit double precision
Unnormalized minimum	0(a)	0(a)	0(a)
maxima			
negative	-1.0×2^{127}	-1.0×2^{127}	-1.0×2^{127}
positive	$(1-2^{-9}) \times 2^{127}$	$(1-2^{-27}) \times 2^{127}$	$(1-2^{-63}) \times 2^{127}$
resolution	1:9(b)	1:27(b)	1:63(b)

- (a) There is no unique representation for the value zero in floating-point binary numbers; any number with mantissa zero has the value zero. However, the processor treats a zero mantissa as a special case in order to preserve precision in later calculations with a zero intermediate result. Whenever the processor detects a zero mantissa as the result of a floating-point binary operation, the AQ-register is cleared to zeros and the E register is set to -128. This representation is known as a floating-point normalized zero. The unnormalized zero (any zero mantissa) will be handled correctly if encountered in an operand but precision may be lost. For example, $A \times 10^{-14} + 0 \times 10^{85}$ will not produce desired results since all the precision of A will be lost when it is aligned to match the 10^{85} exponent of the 0.
- (b) A value cannot be given for resolution in these cases since such a value depends on the value of the exponent, E. The notation used, 1:m, indicates resolution to 1 bit in a field of m. Thus, the following general statement on resolution may be made:

The resolution of a floating-point binary operand with mantissa length m and exponent value E is $2^{(E-m)}$.

DECIMAL DATA

Decimal numbers are expressed in the following forms:

- | | |
|----------------------------|--------------------------|
| Fixed-point, no sign | MMMMMM. |
| Fixed-point, leading sign | +MMMMMM. |
| Fixed-point, trailing sign | MMMMMM.± |
| Floating-point | +MMMMMM.x10 ^E |

The form is specified by control information in the operand descriptor for the operand as used by the Extended Instruction Set (EIS) instructions (see Section 4 for a discussion of the EIS instructions).

A decimal number is defined by imposing any of the byte position value expressions below on a 4- or 9-bit byte information unit of length n bytes.

Fixed-point, no sign:

$$c_0 \times 10^{(n-1)} + c_1 \times 10^{(n-2)} + \dots + c_{(n-1)}$$

Fixed-point, leading sign:

$$[\text{sign}=c_0] c_1 \times 10^{(n-2)} + c_2 \times 10^{(n-3)} + \dots + c_{(n-1)}$$

Fixed-point, trailing sign:

$$c_0 \times 10^{(n-2)} + c_1 \times 10^{(n-3)} + \dots + c_{(n-2)} [\text{sign}=c_{(n-1)}]$$

Floating-point:

$$[\text{sign}=c_0] c_1 \times 10^{(n-3)} + c_2 \times 10^{(n-4)} + \dots + c_{(n-3)} [\text{exponent}=8 \text{ bits}]$$

where:

c_i is the decimal value of the byte in the i^{th} byte position.

$[\text{sign}=c_i]$ indicates that c_i is interpreted as a sign byte.

$[\text{exponent}=8 \text{ bits}]$ indicates that the exponent value is taken from the last 8 bits of the string. If the data is in 9-bit bytes, the exponent is bits 1-8 of $c_{(n-1)}$. If the data is in 4-bit bytes, the exponent is the binary value of the concatenation of $c_{(n-2)}$ and $c_{(n-1)}$.

The decimal number as described above is the only decimal data item defined. It may begin on any legal byte boundary (without regard to word boundaries) and has a maximum extent of 63 bytes.

The processor handles decimal data as 4-bit bytes internally. Thus, 9-bit bytes are high-order truncated as they are transferred from main memory and high-order filled as they are transferred to main memory. The fill pattern is "00011"b for digit bytes and "00010" for sign bytes. The floating-point exponent is a special case and is treated as a fixed-point binary integer.

The processor performs validity checking on decimal data. Only the byte values $[0, 11]_8$ are legal in digit positions and only the byte values $[12, 17]_8$ are legal in sign positions. Detection of an illegal byte value causes an illegal procedure fault. The interpretation of decimal sign bytes is shown in Table 2-4.

Table 2-4. Decimal Sign Character Interpretation

9-bit bytes	4-bit bytes	Interpretation
52 ₈	12 ₈	+
53 ₈ (a)	13 ₈ (b)	+
54 ₈	14 ₈ (a)	+
55 ₈ (a)	15 ₈ (a)	-
56 ₈	16 ₈	+
57 ₈	17 ₈	+

- (a) This value is used as the default sign byte for storage of results. The presence of other values will yield correct results according to the interpretation.
- (b) An optional control bit in the EIS decimal arithmetic instructions (see Section 4) allows the selection of 13₈ for the plus sign byte for storage of results in 4-bit data mode.

Decimal Data Values

The operand descriptors for decimal data operands have a 6-bit fixed-point binary integer field for specification of a scaling factor (SF). This scaling factor has the same effect as the value of E in floating-point decimal operands; a negative value moves the assumed decimal point to the left; a positive value, to the right. The use of the scaling factor extends the range and resolution of decimal data operands. The range of the scaling factor is $[-32, 31]_{10}$. See Table 2-5 for decimal data operand values.

Table 2-5. Decimal Data Values

Operand	Fixed-point unsigned	Fixed-point signed	Floating-point 9-bit	Floating-point 4-bit
Arithmetic minimum	0	0(a)	0(a)	0(a)
maximum	$(10^{63}-1) \times 10^{31}$	$\pm(10^{62}-1) \times 10^{31}$	$\pm(10^{61}-1) \times 10^{158}$	$\pm(10^{60}-1) \times 10^{158}$
resolution	1:SF ^(b)	1:SF ^(b)	1:SF+E ^(c)	1:SF+E ^(c)

- (a) As in floating-point binary arithmetic, there is no unique representation of the value zero except in the case of fixed-point, unsigned data. Therefore, the processor detects a zero result and forces a value of +0. for fixed-point, signed data and $+0.x10^{127}$ for floating-point data. Again, as in floating-point binary arithmetic, other representations of the value zero will be handled correctly except for possible loss of precision during operand alignment.
- (b) A value cannot be given for resolution in these cases since such a value depends on the value of the scaling factor, SF. The notation used, 1:SF, indicates resolution to 1 part in $10^{(SF)}$. Thus, the following general statement on resolution may be made:

The resolution of a fixed-point decimal operand with scaling factor SF is 10^{SF} .

- (c) A value cannot be given for resolution in these cases since such a value depends on the values of the scaling factor, SF, and the exponent, E. The notation used, 1:SF+E, indicates resolution to 1 part in $10^{(SF+E)}$. Thus, the following general statement on resolution may be made:

The resolution of a floating-point decimal operand with scaling factor SF and exponent E is 10^{SF+E} .

Alphanumeric Data

Alphanumeric data is represented in two modes; character-string and bit-string. The mode is determined by the processor according to the function being performed.

CHARACTER STRING DATA

Character string data is defined by imposing the character position structure below on a 4-bit, 6-bit, or 9-bit information unit of length n bytes or characters.

$$c_0 \parallel c_1 \parallel \dots \parallel c_{(n-1)}$$

where:

c_i is the character in the i^{th} character position.

\parallel indicates the concatenation operation.

The character string described above is the only character string data item defined. It may begin on any legal character boundary (without regard to word boundaries) and has a maximum extent as shown in Table 2-6.

Table 2-6. Character String Data Length Limits

Character size	Length limit
9-bit	1048576
6-bit	1572864
4-bit	2097152

No interpretation of the characters is made except as specified for the instruction being executed (see Section 4).

BIT STRING DATA

Bit string data is defined by imposing the bit position structure below on a bit information unit of length n bits.

$$b_0 \parallel b_1 \parallel \dots \parallel b_{(n-1)}$$

where:

b_i is the value of the bit in the i^{th} position.

\parallel indicates the concatenation operation.

The bit string described above is the only bit string data item defined. It may begin at any bit position (without regard to character or word boundaries) and has a maximum extent of 9437184 bits.

SECTION 3

PROGRAM ACCESSIBLE REGISTERS

A processor register is a hardware assembly that holds information for use in some specified way. An accessible register is a register whose contents are available to the user for his purposes. Some accessible registers are explicitly addressed by particular instructions, some are implicitly referenced during the course of execution of instructions, and some are used in both ways. The accessible registers are listed in Table 3-1. See Section 4 for a discussion of each instruction to determine the way in which the registers are used.

Table 3-1. Processor Registers

Register name	Mnemonic	Length (bits)	Quantity
Accumulator Register	A	36	1
Quotient Register	Q	36	1
Accumulator-Quotient Register ^(a)	AQ	72	1
Exponent Register	E	8	1
Exponent-Accumulator-Quotient Register ^(a)	EAQ	80	1
Index Registers	X _n	18	8
Indicator Register	IR	14	1
Base Address Register	BAR	18	1
Timer Register	TR	27	1
Ring Alarm Register	RALR	3	1
Pointer Registers	PR _n	42	8
Address Registers	AR _n	24	8
Procedure Pointer Register ^(b)	PPR	37	1
Temporary Pointer Register ^(b)	TPR	42	1
Descriptor Segment Base Register	DSBR	51	1
Segment Descriptor Word Associative Memory	SDWAM	88	16
Page Table Word Associative Memory	PTWAM	51	16
Fault Register	FR	35	1
Mode Register	MR	33	1
Cache Mode Register	CMR	28	1
Control Unit (CU) History Register		72	16
Operations Unit (OU) History Register		72	16
Decimal Unit (DU) History Register		72	16
Appending Unit (APU) History Register		72	16
Configuration Switch Data		36	5
Control Unit Data		288	1
Decimal Unit Data		288	1

(a) This register is not a separate physical assembly but is a combination of its constituent registers.

(b) This register is not explicitly addressable, but is included because of its vital role in DPS 8M/ p p 980,982P 976,986P in instruction and operand address preparation.

In the descriptions that follow, the diagrams given for register formats do not imply that a physical assembly possessing the pictured bit pattern exists. The diagram is a graphic representation of the form of the register data as it appears in main memory when the register contents are stored or how data bits must be assembled for loading into the register.

If the diagrams contain the characters "x" or "0", the values of the bits in the positions shown are irrelevant to the register. Bits pictured as "x" are not changed when the register is stored. Bits pictured as "0" are set to 0 when the register is stored. Neither "x" bits or "0" bits are loaded into the register.

ACCUMULATOR REGISTER (A)

Format: - 36 bits

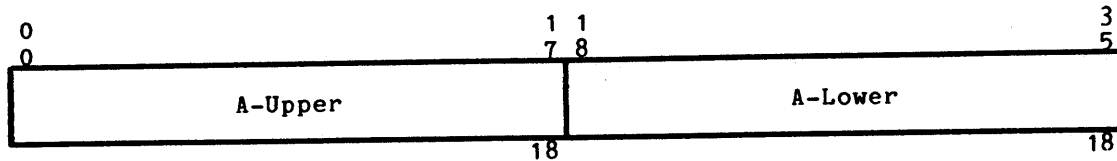

Figure 3-1. Accumulator Register (A) Format

Description:

A 36-bit physical register located in the operations unit.

Function:

In fixed-point binary instructions, holds operands and results.

In floating-point binary instructions, holds the most significant part of the mantissa.

In shifting instructions, holds original data and shifted results.

In address preparation, may hold two logically independent word offsets, A-upper and A-lower, or an extended range bit- or character-string length.

QUOTIENT REGISTER (Q)

Format: - 36 bits

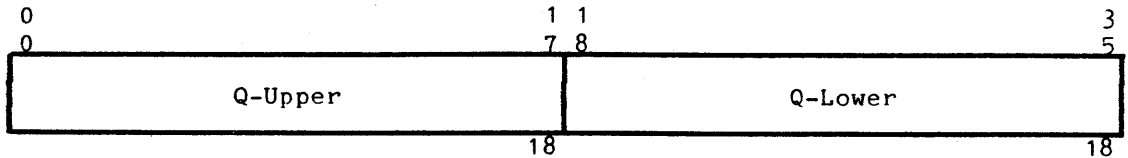

Figure 3-2. Quotient Register (Q) Format

Description:

A 36-bit physical register located in the operations unit.

Function:

In fixed-point binary instructions, holds operands and results.

In floating-point binary instructions, holds the least significant part of the mantissa.

In shifting instructions, holds original data and shifted results.

In address preparation, may hold two logically independent word offsets, Q-upper and Q-lower, or an extended range bit- or character-string length.

ACCUMULATOR-QUOTIENT REGISTER (AQ)

Format: - 72 bits

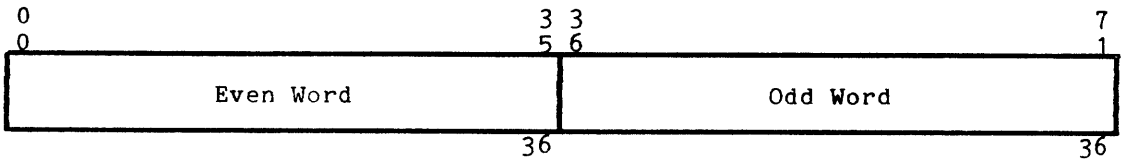

Figure 3-3. Accumulator-Quotient Register (AQ) Format

Description:

A combination of the accumulator (A) and quotient (Q) registers.

Function:

In fixed-point binary instructions, holds double-precision operands and results.

In floating-point binary instructions, holds the mantissa.

In shifting instructions, holds original data and shifted results.

EXPONENT REGISTER (E)

Format: - 8 bits

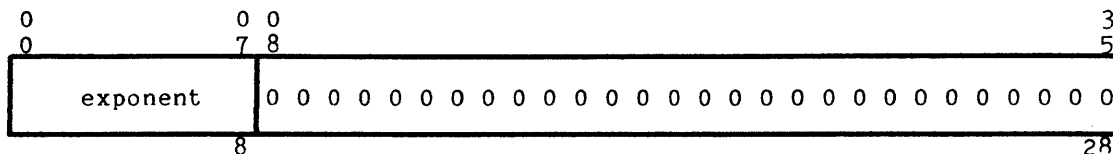

Figure 3-4. Exponent Register (E) Format

Description:

An 8-bit physical register located in the operations unit.

Function:

In floating-point binary instructions, holds the exponent.

EXPONENT-ACCUMULATOR-QUOTIENT REGISTER (EAQ)

Format: - 80 bits

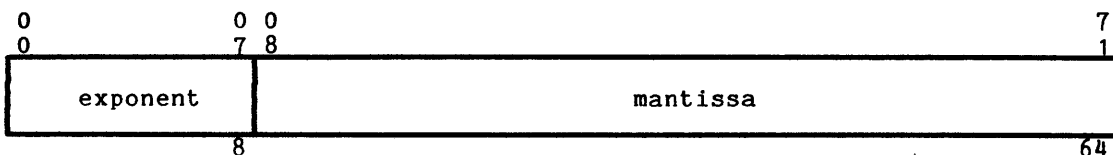

Figure 3-5. Exponent-Accumulator-Quotient Register (EAQ) Format

Description:

A combination of the exponent (E), accumulator (A), and quotient (Q) registers. Although the combined register has a total of 80 bits, only 72 are involved

in transfers to and from main memory. The 8 low-order bits are discarded on store and zero-filled on load.

Function:

In floating-point binary instructions, holds operands and results.

INDEX REGISTERS (Xn)

Format: - 18 bits each

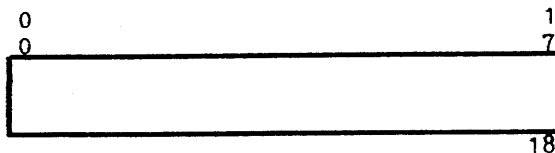

Figure 3-6. Index Register (X_n) Format

Description:

Eight 18-bit physical registers in the operations unit numbered 0 through 7. Index register data may occupy the position of either an upper or lower 18-bit half-word operand (see Section 2).

Function:

In fixed-point binary instructions, hold half-word operands and results.

In address preparation, hold word offsets or extended range bit- or character-string lengths.

INDICATOR REGISTER (IR)

Format: - 14 bits

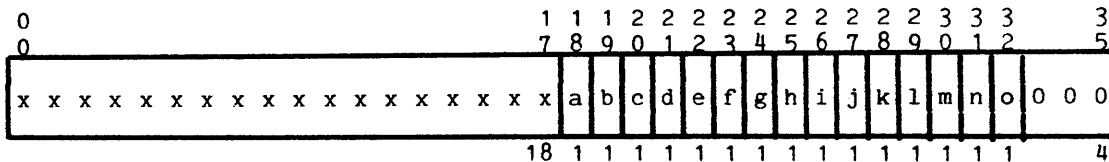

Figure 3-7. Indicator Register (IR) Format

Description:

An assemblage of 15 indicator flags from various units of the processor. The data occupies the position of a lower 18-bit half word operand (see Section 2). When interpreted as data, a bit value of 1 corresponds to the ON state of the indicator, a bit value of 0 corresponds to the OFF state.

Function:

The functions of the individual indicator bits are given below. An "x" in the column headed "L" indicates that the state of the indicator is not affected by instructions that load the IR.

<u>key</u>	<u>L</u>	<u>Indicator name</u>	<u>Action</u>
a		Zero	This indicator is set ON whenever the output of the main binary adder consists entirely of zero bits for binary or shifting instructions or the output of the decimal adder consists entirely of zero digits for decimal instructions; otherwise, it is set OFF.
b		Negative	This indicator is set ON whenever the output of bit 0 of the main binary adder has value 1 for binary or shifting instructions or the sign character of the result of a decimal instruction is the negative sign character; otherwise, it is set OFF.
c		Carry	This indicator is set ON for any of the following conditions; otherwise, it is set OFF. (1) If a bit propagates leftward out of bit 0 of the main binary adder for any binary or shifting instruction. (2) If $ value1 = < value2 $ for a decimal numeric comparison instruction. (3) If $char1 = < char2$ for a decimal alphanumeric compare instruction.
d		Overflow	This indicator is set ON if the arithmetic range of a register is exceeded in a fixed-point binary instruction or if the target string of a decimal numeric instruction is too small to hold the integer part of the result. It remains ON until reset by the Transfer On Overflow (tov) instruction or is reset by some other instruction that loads the IR. The event that sets this indicator ON may also cause an overflow fault. (See overflow mask indicator below.)
e		Exponent overflow	This indicator is set ON if the exponent of the result of a floating-point binary or decimal numeric instruction is greater than +127. It remains ON until reset by the Transfer On Exponent Overflow (teo) instruction or is reset by some other instruction that loads the IR. The event that sets this indicator ON may also cause an overflow fault. (See overflow mask indicator below.)

<u>key</u>	<u>L</u>	<u>Indicator name</u>	<u>Action</u>
f		Exponent underflow	This indicator is set ON if the exponent of the result of a floating-point binary or decimal numeric instruction is less than -128. It remains ON until reset by the Transfer On Exponent Underflow (teu) instruction or is reset by some other instruction that loads the IR. The event that sets this indicator ON may also cause an overflow fault. (See overflow mask indicator below.)
g		Overflow mask	This indicator is set ON or OFF only by the instructions that load the IR. When set ON, the IR inhibits the generation of the fault for those events that normally cause an overflow fault. If the overflow mask indicator is set OFF after occurrence of an overflow event, an overflow fault does not occur even though the indicator for that event is still set ON. The state of the overflow mask indicator does not affect the setting, testing, or storing of any other indicator.
h		Tally runout	This indicator is set OFF at initialization of any tallying operation, that is, any repeat instruction or any indirect then tally address modification. It is then set ON for any of the following conditions: <ul style="list-style-type: none"> (1) If any repeat instruction terminates because of tally exhaust. (2) If a Repeat Link (rpl) instruction terminates because of a zero link address. (3) If a tally exhaust is detected for an indirect then tally modifier. The instruction is executed whether or not tally exhaust occurs. (4) If an EIS string scanning instruction reaches the end of the string without finding a match condition.
i		Parity error	This indicator is set ON whenever a system controller signals illegal action with a parity error code or the processor detects an internal parity error condition. The indicator is set OFF only by instructions that load the IR.
j		Parity mask	This indicator is set ON or OFF only by the instructions that load the IR and is changed only when the processor is in privileged or absolute mode. When it is set ON, the IR inhibits the generation of the parity fault for all events that set the parity error indicator. If the parity mask indicator is set OFF after the occurrence of a parity error event, a parity fault does not occur even though the parity error indicator may still be set ON. The state of the parity mask indicator does not affect the loading, testing, or storing of any other indicator.
k	x	Not BAR mode	This indicator is set OFF (placing the processor in BAR mode) only by execution of the Transfer

key L Indicator name

Action

and Set Slave (tss) instruction or by the operand data of the Restore Control Unit (rcu) instruction and is changed only when the processor is in privileged or absolute mode. It is set ON (taking the processor out of BAR mode) by the execution of any transfer instruction other than tss during a fault or interrupt trap. (See Section 7.) If a fault or interrupt trap occurs while in BAR mode and the IR is stored before any transfer occurs, then a Return (ret) or Restore Control Unit (rcu) instruction that reloads the stored data will return the processor to BAR mode.

l Truncation

This indicator is set ON whenever the target string of a decimal numeric instruction is too small to hold all the digits of the result or the target string of an alphanumeric instruction is too small to hold all the bits or characters to be stored. (Also see the overflow indicator for decimal numeric instructions.) The event that sets this indicator ON may also cause an overflow fault. (See overflow mask indicator above.)

m Mid instruction interrupt fault

This indicator is set OFF at the start of execution of each instruction and is set ON by the events described below. The indicator has meaning only when determining the proper restart sequence for the interrupted instruction. This indicator can be set on:

- (1) By any fault during execution of an EIS instruction; however, the state is safe-stored in the Control Unit Data only for access violation and directed faults.
- (2) By an interrupt signal during execution of those EIS instructions that allow very long operand strings.
- (3) If the processor is in absolute or privileged mode, by the execution of a Load Indicator Register (ldi), Return (ret), or Restore Control Unit (rcu) instruction with bit 30 set to 1 in the IR data.

n x Absolute mode

This indicator is set ON (placing the processor in absolute mode) when the processor is initialized and by execution of a nonappended transfer instruction during a fault or interrupt trap and is set OFF (placing the processor in append mode) by any execution of an appended transfer instruction. If the processor is not in absolute mode when the fault or interrupt occurs and the transfer instruction is Return (ret) or Restore Control Unit (rcu) and the appropriate mode bit is properly set in the IR data, the processor remains in its current mode.

o Hex mode

When the hexadecimal permission indicator (bit 33 of the Mode Register) is set on and this indicator is also on, then the exponent of a

floating point number has a power of 16 rather than a power of two (binary floating point). The state of the hex mode indicator can be changed by executing a Load Indicator Register (ldi), Return (ret), or Restore Control Unit (rcu), instruction with the desired state (1 or 0) set in bit 32 of the IR data. Hexadecimal mode is only available on DPS 8M processors. Indicator Register bit 32 is set to a zero value on DPS/L68 processors

BASE ADDRESS REGISTER (BAR)

Format: - 18 bits

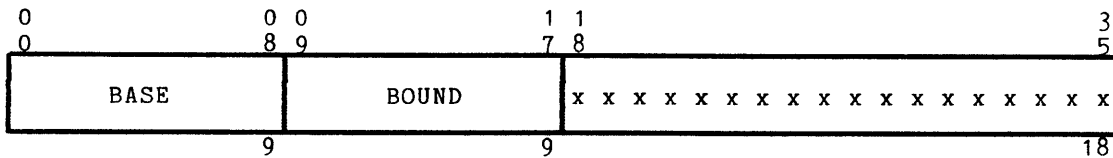

Figure 3-8. Base Address Register (BAR) Format

Description:

An 18-bit physical register in the control unit.

Function:

The Base Address Register provides automatic hardware Address relocation and Address range limitation when the processor is in BAR mode.

- BAR.BASE Contains the 9 high-order bits of an 18-bit address relocation constant. The low-order bits are generated as zeros.
- BAR.BOUND Contains the 9 high-order bits of the unrelocated address limit. The low-order bits are generated as zeros. An attempt to access main memory beyond this limit causes a store fault, out of bounds. A value of 0 is truly 0, indicating a null memory range.

TIMER REGISTER (TR)

Format: - 27 bits

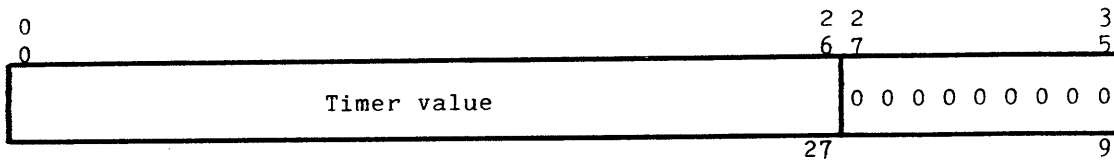

Figure 3-9. Timer Register (TR) Format

Description:

A 27-bit settable, free-running clock in the control unit. The value decrements at a rate of 512 kHz. Its range is 1.953125 microseconds to approximately 4.37 minutes.

Function:

The TR may be loaded with any convenient value with the privileged Load Timer (ldt) instruction. When the value next passes through zero, a timer runout fault is signalled. If the processor is in normal or BAR mode with interrupts not inhibited or is stopped at an uninhibited Delay Until Interrupt Signal (dis) instruction, the fault occurs immediately. If the processor is in absolute or privileged mode or has interrupts inhibited, the fault is delayed until the processor returns to uninhibited normal or BAR mode or stops at an uninhibited Delay Until Interrupt Signal (dis) instruction.

RING ALARM REGISTER (RALR)

Format: - 3 bits

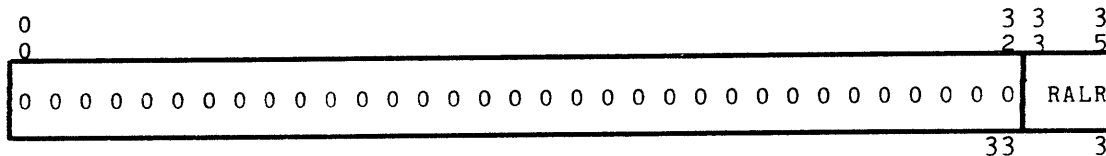

Figure 3-10. Ring Alarm Register (RALR) Format

Description:

A 3-bit physical register in the appending unit.

Function:

If the RALR contains a value other than zero and the effective ring number (see TPR.TRR below) is greater than or equal to the contents of the RALR and the instruction for which an absolute main memory address is being prepared is a transfer instruction, an access violation, ring alarm, fault occurs. Operating system software may use this register to detect crossings from inner rings to outer rings.

POINTER REGISTERS (PR_n)

Format: - 42 bits each

Even word of ITS pointer pair

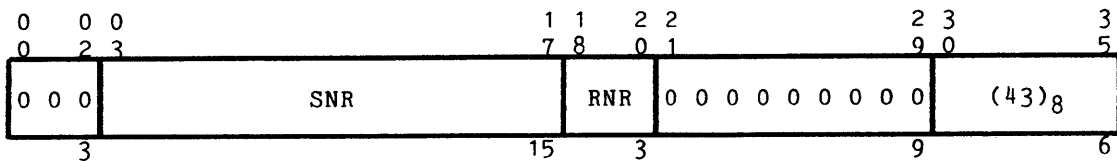

Odd word of ITS pointer pair

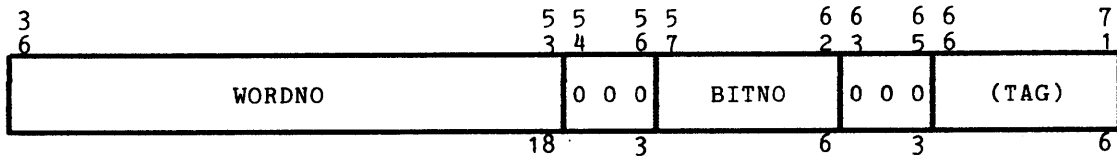

Data as stored by Store Pointer Register n Packed (sprpn)

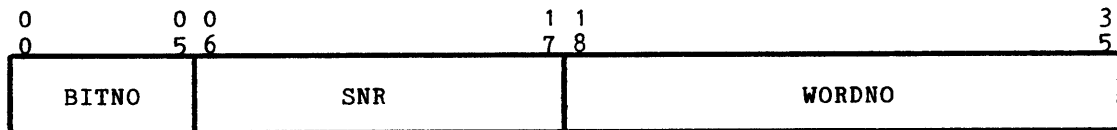

Figure 3-11. Pointer Register (PR_n) Format

Description:

Eight combinations of physical registers from the appending unit and decimal unit numbered 0 through 7. PR_n.RNR, PR_n.SNR, and PR_n.BITNO are located in the appending unit and PR_n.WORDNO is located in the decimal unit. The WORDNO registers also form part of the address registers discussed later in this section.

Function:

The pointer registers hold information relative to the location in main memory of data items that may be external to the segment containing the procedure being executed. The functions of the individual constituent registers are:

<u>Register</u>	<u>Function</u>
PR _n .SNR	The segment number of the segment containing the data item described by the pointer register.
PR _n .RNR	The final effective ring number value calculated during execution of the instruction that last loaded the PR.
(43) ₈	This field is not part of the PR but is generated each time the PR is stored as an ITS pair.
PR _n .WORDNO	The offset in words from the base or origin of the segment to the data item.
PR _n .BITNO	The number of the bit within PR _n .WORDNO that is the first bit of the data item. Data items aligned on word boundaries always have the value 0. Unaligned data items may have any value in the range [1,35].
(TAG)	This field is not part of the PR but, in an ITS pointer pair, holds an address modifier for use in address preparation.

ADDRESS REGISTERS (AR_n)

Format: - 24 bits each

Data as stored by Store Address Register n (sAR_n)

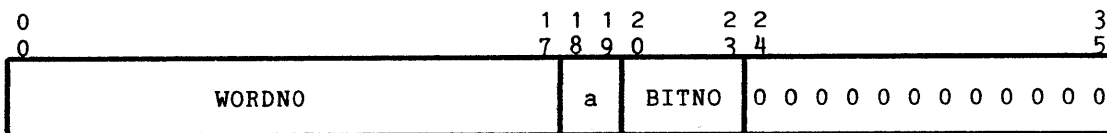

Figure 3-12. Address Register (AR_n) Format

Description:

Eight combinations of physical registers from the decimal unit numbered 0 through 7. The WORDNO registers also form part of the pointer registers discussed earlier in this section.

Function:

The address registers hold information relative to the location in main memory of the next bit, character, or byte of an EIS operand to be processed

by an EIS instruction. The functions of the individual constituent registers are:

<u>key Register</u>	<u>Function</u>
AR _n .WORDNO	The offset in words relative to the current addressing base referent (segment origin, BAR.BASE, or absolute 0 depending on addressing mode) to the word containing the next data item element.
a AR _n .CHAR	The number of the 9-bit byte within AR _n .WORDNO containing the first bit of the next data item element.
AR _n .BITNO	The number of the bit within AR _n .CHAR that is the first bit of the next data item element.

NOTE: The reader's attention is directed to the presence of two bit number registers, PR_n.BITNO and AR_n.BITNO. Because the Multics processor was implemented as an enhancement to an existing design, certain apparent anomalies appear. One of these is the difference in the handling of unaligned data items by the appending unit and decimal unit. The decimal unit handles all unaligned data items with a 9-bit byte number and bit offset within the byte. Conversion from the description given in the EIS operand descriptor is done automatically by the hardware. The appending unit maintains compatibility with the earlier generation Multics processor by handling all unaligned data items with a bit offset from the prior word boundary; again with any necessary conversion done automatically by the hardware. Thus, a pointer register, PR_i, may be loaded from an ITS pointer pair having a pure bit offset and modified by one of the EIS address register instructions (a4bd, s9bd, etc.) using character displacement counts. The automatic conversion performed ensures that the pointer register, PR_i, and its matching address register, AR_i, both describe the same physical bit in main memory.

SPECIAL NOTICE: The decimal unit has built-in hardware checks for illegal bit offset values but the appending unit does not except for a single case for packed pointers. See NOTES for Load Packed Pointers (lprpn) in Section 4.

PROCEDURE POINTER REGISTER (PPR)

Format: - 37 bits

Shown as part of word 0 of control unit data

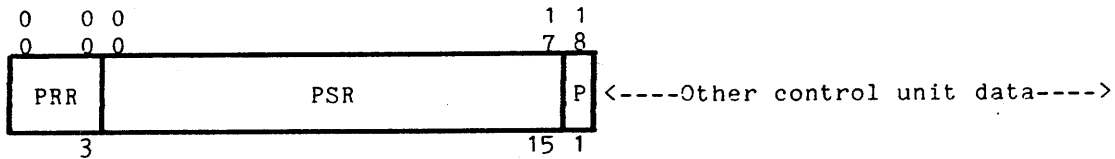

Shown as part of word 4 of control unit data

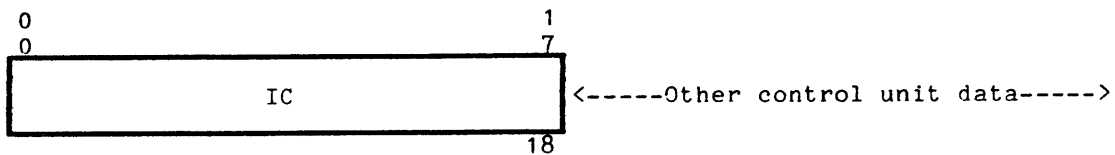

Figure 3-13. Procedure Pointer Register (PPR) Format

Description:

A combination of physical registers from the appending unit and the control unit. PPR.PRR, PPR.PSR, and PPR.P are located in the appending unit and PPR.IC is located in the control unit. The PPR is not explicitly addressable but its data is extracted and stored as part of the data stored with the Store Control Unit (scu) and Store Control Double (stdc) instructions. It is loaded from the control unit data with the Restore Control Unit (rcu) instruction.

Function:

The Procedure Pointer Register holds information relative to the location in main memory of the procedure segment in execution and the location of the current instruction within that segment. The functions of the individual constituent registers are:

<u>Register</u>	<u>Function</u>
PPR.PRR	The number of the ring in which the process is executing. It is set to the effective ring number of the procedure segment when control is transferred to the procedure.
PPR.PSR	The segment number of the procedure being executed.
PPR.P	A flag controlling execution of privileged instructions. Its value is 1 (permitting execution of privileged instructions) if PPR.PRR is 0 and the privileged bit in the segment descriptor word (SDW.P) for the procedure is 1; otherwise, its value is 0.

PPR.IC

The word offset from the origin of the procedure segment to the current instruction.

TEMPORARY POINTER REGISTER (TPR)

Format: - 42 bits

Shown as part of word 2 of control unit data

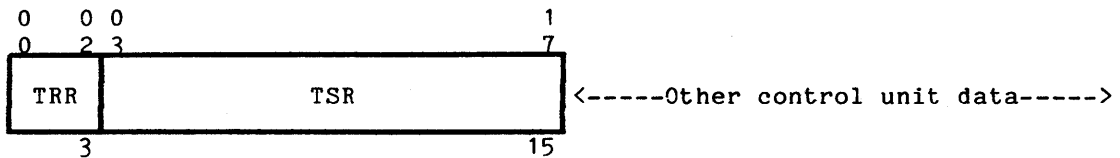

Shown as part of word 3 of control unit data

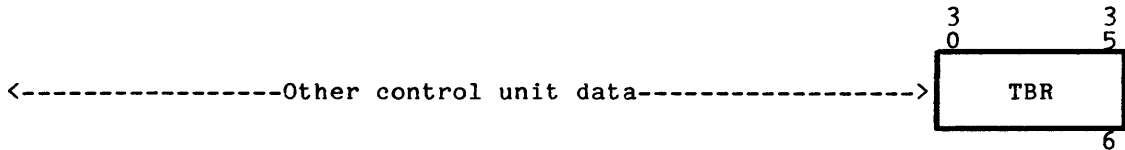

Shown as part of word 5 of control unit data

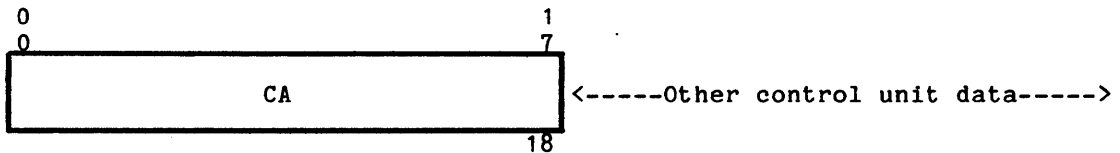

Figure 3-14. Temporary Pointer Register (TPR) Format

Description:

A combination of physical registers from the appending unit and the control unit. TPR.TRR, TPR.TSR, and TPR.TBR are located in the appending unit and TPR.CA is located in the control unit. The TPR is not explicitly addressable but its data is extracted and stored as part of the data stored with the Store Control Unit (scu) instruction. It is loaded from the control unit data with the Restore Control Unit (rcu) instruction.

Function:

The temporary pointer register holds the current virtual address used by the processor in performing address preparation for operands, indirect words, and instructions. At the completion of address preparation, the contents of the TPR is presented to the appending unit associative memories for

translation into the 24-bit absolute main memory address. The functions of the individual constituent registers are:

<u>Register</u>	<u>Function</u>
TPR.TRR	The current effective ring number (see Section 8).
TPR.TSR	The current effective segment number (see Section 8).
TPR.TBR	The current bit offset as calculated from ITS and ITP pointer pairs. (See Section 8.)
TPR.CA	The current computed address relative to the origin of the segment whose segment number is in TPR.TSR. (See Section 8.)

DESCRIPTOR SEGMENT BASE REGISTER (DSBR)

Format: - 51 bits

Even word of Y-pair as stored by Store Descriptor Base Register (sdbR)

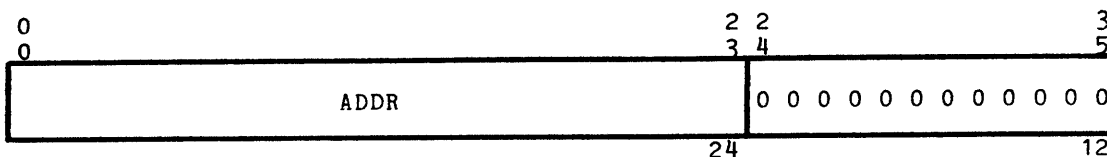

Odd word of Y-pair as stored by Store Descriptor Base Register (sdbR)

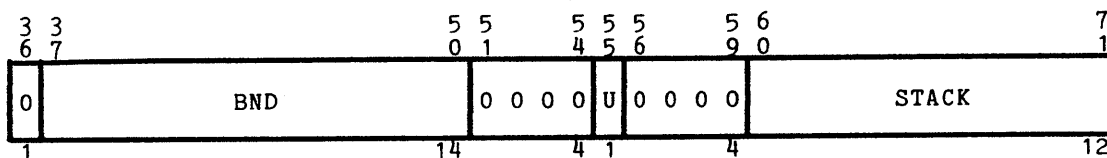

Figure 3-15. Descriptor Segment Base Register (DSBR) Format

Description:

A physical register in the appending unit.

Function:

The Descriptor Segment Base Register contains information concerning the descriptor segment being used by the processor. The descriptor segment holds the segment descriptor words (SDWs) for all segments accessible by the processor, that is, the currently defined virtual address space. The functions of its individual constituent registers are:

<u>Register</u>	<u>Function</u>
DSBR.ADDR	If DSBR.U = 1, the 24-bit absolute main memory address of the origin of the current descriptor segment; otherwise, the 24-bit absolute main memory address of the page table for the current descriptor segment.
DSBR.BND	The 14 most significant bits of the highest Y-block16 address of the descriptor segment that can be addressed without causing an access violation, out of segment bounds, fault.
DSBR.U	A flag specifying whether the descriptor segment is unpagged (U = 1) or pagged (U = 0).
DSBR.STACK	The upper 12 bits of the 15-bit stack base segment number. It is used only during the execution of the call6 instruction. (See Section 8 for a discussion of generation of the stack segment number.)

SEGMENT DESCRIPTOR WORD ASSOCIATIVE MEMORY (SDWAM) - DPS/L68 and DPS 8M

Format: - 88 bits each

Even word of Y-pairs as stored by Store Segment Descriptor Registers (ssdr)

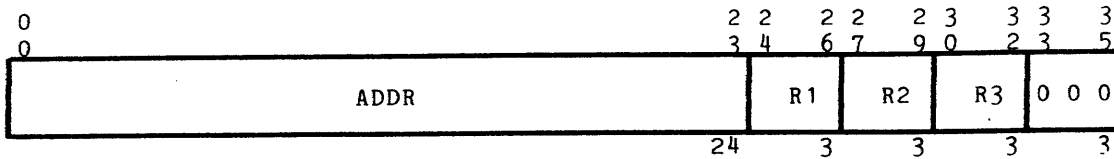

Odd word of Y-pairs as stored by Store Segment Descriptor Registers (ssdr)

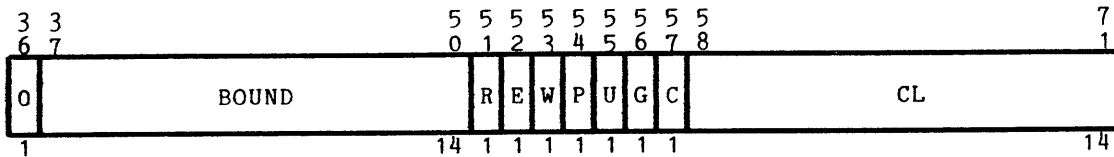

Data as stored by Store Segment Descriptor Pointers (ssdp)

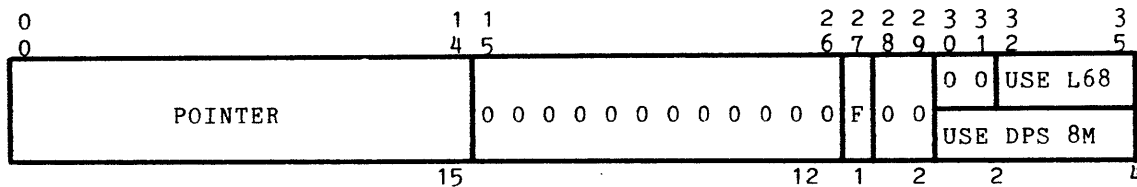

Figure 3-16. Segment Descriptor Word Associative Memory (SDWAM) Format
DPS/L68 and DPS 8M

Description:

A combination of 16 registers and flags from the appending unit constitute the Segment Descriptor Word Associative Memory (SDWAM). The registers are numbered consecutively from 0 through 15 but are not explicitly addressable by number.

For the DPS 8M processors, the SDW associative memory will hold the 16 most recently used (MRU) SDWs and have a full associative organization with least recently used (LRU) replacement.

For the DPS 8M processor, the SDW associative memory will hold the 64 MRU SDWs and have a 4-way set associative organization with LRU replacement.

Function:

Hardware segmentation in the Multics processor is implemented by the appending unit (see Section 5 for details). In order to permit addressing by segment number and offset as prepared in the temporary pointer register (described

earlier), a table containing the location and status of each accessible segment must be kept. This table is the descriptor segment. The descriptor segment is located by information held in the descriptor segment base register (DSBR) described earlier.

Every time an effective segment number (TPR.TSR) is prepared, it is used as an index into the descriptor segment to retrieve the segment descriptor word (SDW) for the target segment. To reduce the number of main memory references required for segment addressing, the SDWAM provides a content addressable memory to hold the sixteen most recently referenced SDWs.

Whenever a reference to the SDW for a segment is required, the effective segment number (TPR.TSR) is matched associatively against all 16 SDWAM.POINTER registers (described below). If the SDWAM match logic circuitry indicates a hit, all usage counts (SDWAM.USE) greater than the usage count of the register hit are decremented by one, the usage count of the register hit is set to 15, and the contents of the register hit are read out into the address preparation circuitry. If the SDWAM match logic does not indicate a hit, the SDW is fetched from the descriptor segment in main memory and loaded into the SDWAM register with usage count 0 (the oldest), all usage counts are decremented by one with the newly loaded register rolling over from 0 to 15, and the newly loaded register is read out into the address preparation circuitry. Faulted SDWs are not loaded into the SDWAM.

The functions of the constituent registers and flags of each SDWAM register areas follows:

<u>Register</u>	<u>Function</u>
SDWAM.ADDR	The 24-bit absolute main memory address of the page table for the target segment if SDWAM.U = 0; otherwise, the 24-bit absolute main memory address of the origin of the target segment.
SDWAM.R1	Upper limit of read/write ring bracket (see Section 8).
SDWAM.R2	Upper limit of read/execute ring bracket (see Section 8).
SDWAM.R3	Upper limit of call ring bracket (see Section 8).
SDWAM.BOUND	The 14 high-order bits of the last Y-block16 address within the segment that can be referenced without an access violation, out of segment bound, fault.
SDWAM.R	Read permission bit. If this bit is set ON, read access requests are allowed.
SDWAM.E	Execute permission bit. If this bit is set ON, the SDW may be loaded into the procedure pointer register (PPR) and instructions fetched from the segment for execution.
SDWAM.W	Write permission bit. If this bit is set ON, write access requests are allowed.
SDWAM.P	Privileged flag bit. If this bit is set ON, privileged instructions from the segment may be executed if PPR.PRR is 0.
SDWAM.U	Unpaged flag bit. If this bit is set ON, the segment is unpaged and SDWAM.ADDR is the 24-bit absolute main memory address of the origin of the segment. If this bit is set OFF, the segment is paged and SDWAM.ADDR is the 24-bit absolute main memory address of the page table for the segment.

<u>Register</u>	<u>Function</u>
SDWAM.G	Gate control bit. If this bit is set OFF, calls and transfers into the segment must be to an offset no greater than the value of SDWAM.CL as described below.
SDWAM.C	Cache control bit. If this bit is set ON, data and/or instructions from the segment may be placed in the cache memory.
SDWAM.CL	Call limiter (entry bound) value. If SDWAM.G is set OFF, transfers of control into the segment must be to segment addresses no greater than this value.
SDWAM.POINTER	The effective segment number used to fetch this SDW from main memory.
SDWAM.F	Full/empty bit. If this bit is set ON, the SDW in the register is valid. If this bit is set OFF, a hit is not possible. All SDWAM.F bits are set OFF by the instructions that clear the SDWAM.
SDWAM.USE	Usage count for the register. The SDWAM.USE field is used to maintain a strict FIFO queue order among the SDWs. When an SDW is matched, its USE value is set to 15 (newest) on the DPS/L68 and to 63 on the DPS 8M, and the queue is reordered. SDWs newly fetched from main memory replace the SDW with USE value 0 (oldest) and the queue is reordered.

PAGE TABLE WORD ASSOCIATIVE MEMORY (PTWAM) - DPS/L68 and DPS 8M

Format: - 51 bits each

Data as stored by Store Page Table Registers (sptr)

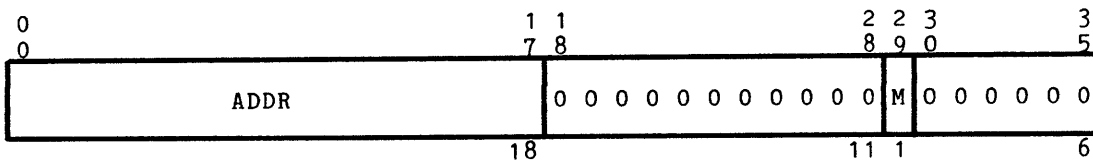

Data as stored by Store Page Table Pointers (sptp)

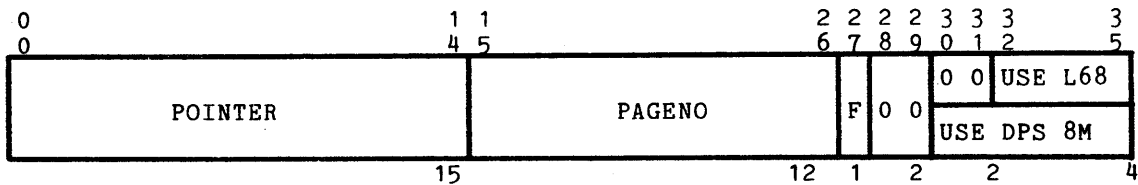

Figure 3-17. Page Table Word Associative Memory (PTWAM) Format
DPS/L68 and DPS 8M

Description:

A combination of 16 registers and flags from the appending unit constitute the Page Table Word Associative Memory (PTWAM). The registers are numbered consecutively from 0 through 15 but are not explicitly addressable by number.

For the DPS 8M processors, the PTW associative memory will hold the 16 most recently used (MRU) PTWs and have a full associative organization with least recently used (LRU) replacement.

For the DPS 8M processors, the PTW associative memory will hold the 64 MRU PTWs and have a 4-way set associative organization with LRU replacement.

Function:

Hardware paging in the Multics processor is implemented by the appending unit (see Section 5 for details). In order to permit segment addressing by page number and page offset as derived from the computed address prepared in the temporary pointer register (TPR.CA described above), a table containing the location and status of each page of an accessible segment must be kept. This table is the page table for the segment. The page table for an accessible paged segment is located by information held in the segment descriptor word (SDW) for the segment.

Every time a computed address (TPR.CA) for a paged segment is prepared, it is separated into a page number and a page offset. The page number is used as an index into the page table to retrieve the page table word (PTW) for the target page. To reduce the number of main memory references required for paging, the PTWAM provides a content addressable memory to hold the 16 most recently referenced PTWs.

Whenever a reference to the PTW for a page of a paged segment is required, the page number (as derived from TPR.CA) is matched associatively against all 16 PTWAM.PAGENO registers (described below) and, simultaneously, TPR.TSR is matched against PTWAM.POINTER (described below). If the PTWAM match logic circuitry indicates a hit, all usage counts (PTWAM.USE) greater than the usage count of the register hit are decremented by one, the usage count of the register hit is set to 15, and the contents of the register hit are read out into the address preparation circuitry. If the PTWAM match logic does not indicate a hit, the PTW is fetched from main memory and loaded into the PTWAM register with usage count 0 (the oldest), all usage counts are decremented by one with the newly loaded register rolling over from 0 to 15, and the newly loaded register is read out into the address preparation circuitry. Faulted PTWs are not loaded into the PTWAM.

The functions of the constituent registers and flags of each PTWAM register are: (See Section 8 for additional details.)

<u>Register</u>	<u>Function</u>
PTWAM.ADDR	The 18 high-order bits of the 24-bit absolute main memory address of the page. The hardware ignores low-order bits of this page address according to page size based on the following:

<u>Page size in words</u>	<u>ADDR bits ignored</u>
64	none
128	17
256	16-17
512	15-17
1024	14-17
2048	13-17
4096	12-17

PTWAM.M	Page modified flag bit. This bit is set ON whenever the PTW is used for a store type instruction. When the bit changes value from 0 to 1, a special extra cycle is generated to write it back into the PTW in the page table in main memory.
---------	--

PTWAM.POINTER	The effective segment number used to fetch this PTW from main memory.
---------------	---

PTWAM.PAGENO	The 12 high-order bits of the 18-bit computed address (TPR.CA) used to fetch this PTW from main memory. Low-order bits are forced to zero by the hardware and not used as part of the page table index according to page size based on the following:
--------------	---

<u>Page size in words</u>	<u>PAGENO bits forced</u>
64	none
128	11
256	10-11
512	09-11
1024	08-11
2048	07-11
4096	06-11

PTWAM.F	Full/empty bit. If this bit is set ON, the PTW in the register is valid. If this bit is set OFF, a hit is not possible. All PTWAM.F bits are set OFF by the instructions that clear the PTWAM.
---------	--

PTWAM.USE	Usage count for the register. The PTWAM.USE field is used to maintain a strict FIFO queue order among the PTWs. When an PTW is matched its USE value is set to 15 (newest) on the DPS/L68 and to 63 on the DPS 8M, and the queue is reordered. PTWs newly fetched from main memory replace the PTW with USE value 0 (oldest) and the queue is reordered.
-----------	--

FAULT REGISTER (FR) - DPS/L68

Format: - 72 bits

Even word of Y-pair as stored by Store Central Processor Register (scpr), TAG = 01

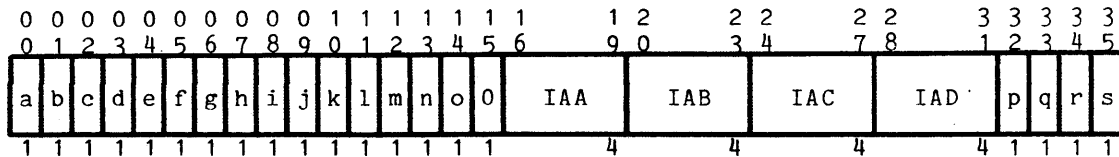

Odd word of Y-pair as stored by Store Central Processor Register (scpr), TAG = 01

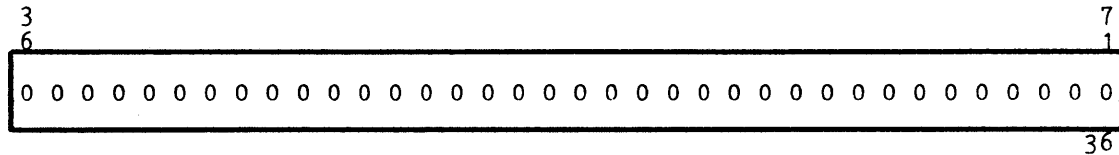

Figure 3-18. Fault Register (FR) Format - DPS and L68

Description:

A combination of flags and registers all located in the control unit. The register is stored and cleared by the Store Central Processor Register (scpr), TAG = 01, instruction. Note that the data is stored into the word pair at location Y. The Fault Register cannot be loaded.

Function:

The Fault Register contains the conditions in the processor for several of the hardware faults. Data is strobed into the Fault Register during a fault sequence. Once a bit or field in the Fault register is set, it remains set until the register is stored and cleared. The data is not overwritten during subsequent fault events.

The functions of the constituent flags and registers are:

<u>Flag or key register</u>	<u>Function</u>
a ILL OP	An illegal operation code has been detected.
b ILL MOD	An illegal address modifier has been detected.
c ILL SLV	An illegal BAR mode procedure has been encountered.
d ILL PROC	An illegal procedure other than the three above has been encountered.

<u>key</u>	<u>Flag or register</u>	<u>Function</u>
e	NEM	A nonexistent main memory address has been requested.
f	OOB	A BAR mode boundary violation has occurred.
g	ILL DIG	An illegal decimal digit or sign has been detected by the decimal unit.
h	PROC PARU	A parity error has been detected in the upper 36 bits of data.
i	PROC PARL	A parity error has been detected in the lower 36 bits of data.
j	\$CON A	A \$CONNECT signal has been received through port A.
k	\$CON B	A \$CONNECT signal has been received through port B.
l	\$CON C	A \$CONNECT signal has been received through port C.
m	\$CON D	A \$CONNECT signal has been received through port D.
n	DA ERR1	Operation not complete. Processor/system controller interface sequence error 1 has been detected. (\$DATA-AVAIL received with no prior \$INTERRUPT sent.)
o	DA ERR2	Operation not complete. Processor/system controller interface sequence error 2 has been detected. (Multiple \$DATA-AVAIL received or \$DATA-AVAIL received out of order.)
	IAA	Coded illegal action, port A. (see Table 3-2)
	IAB	Coded illegal action, port B. (See Table 3-2)
	IAC	Coded illegal action, port C. (See Table 3-2)
	IAD	Coded illegal action, port D. (See Table 3-2)
p	CPAR DIR	A parity error has been detected in the cache memory directory.
q	CPAR STR	A data parity error has been detected in the cache memory.
r	CPAR IA	An illegal action has been received from a system controller during a store operation with cache memory enabled. This implies that the data are correct in cache memory and incorrect in main memory.
s	CPAR BLK	A cache memory parity error has occurred during a cache memory data block load.

Table 3-2. System Controller Illegal Action Codes

Code	Priority	Fault	Reason
00	--		No illegal action
01	--	Command	Unassigned
02	05	Store	Nonexistent address
03	01	Command	Stop on condition
04	--	Command	Unassigned
05	12	Parity	Data parity, store unit to system controller
06	11	Parity	Data parity in store unit
07	10	Parity	Data parity in store unit and store unit to system controller
10	04	Command	Not control ^(a)
11	13	Command	Port not enabled
12	03	Command	Illegal command
13	07	Store	Store unit not ready
14	02	Parity	Zone-address-command parity, processor to system controller
15	06	Parity	Data parity, processor to system controller
16	08	Parity	Zone-address-command parity, system controller to store unit
17	09	Parity	Data parity, system controller to store unit

(a) This illegal action code not relevant to later model system controllers.

FAULT REGISTER (FR) - DPS 8M

Format: - 72 bits

Even word of Y-pair as stored by Store Control Processor Register (scpr), TAG = 01

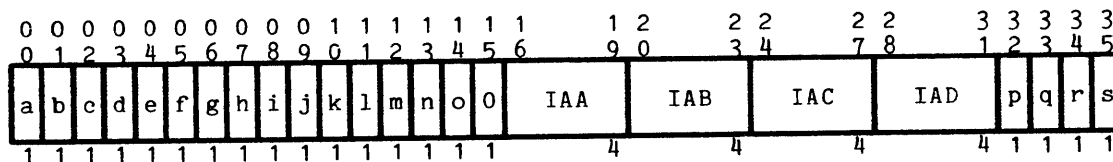

Odd word of Y-pair is stored by Store Control Processor Register (scpr), TAG = 01

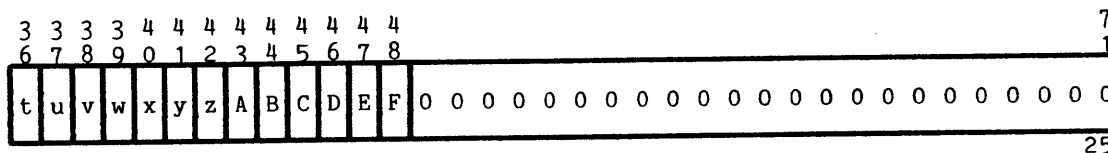

Figure 3-19. Fault Register (FR) Format - DPS 8M

Function:

The Fault Register contains the conditions in the processor for several of the hardware faults on the DPS 8M CPU and cache directory buffer overflows. Data is strobed into the Fault Register during a fault or buffer overflow fault sequence. Once a bit or field in the Fault Register is set, it remains set until the register is stored and cleared. The data is not overwritten during subsequent fault events.

The functions of the constituent flags and registers are:

<u>key</u>	<u>Flag or register</u>	<u>Fault</u>	<u>Function</u>
a	ILL OP	IPR	An illegal operation code has been detected.
b	ILL MOD	IPR	An illegal address modifier has been detected.
c	ILL SLV	IPR	An illegal BAR mode procedure has been encountered.
d	ILL PROC	IPR	An illegal procedure other than the three above has been encountered.
e	NEM	ONC	A nonexistent main memory address has been requested.
f	OOB	STR	A BAR mode boundary violation has occurred.
b	ILL DIG	IPR	An illegal decimal digit or sign has been detected by the decimal unit.
h	PROC PARU	PAR	A parity error has been detected in the upper 36 bits of data.
i	PROC PARL	PAR	A parity error has been detected in the lower 36 bits of data.
j	\$CON A	CON	A \$CONNECT signal has been received through port A.
k	\$CON B	CON	A \$CONNECT signal has been received through port B.
l	\$CON C	CON	A \$CONNECT signal has been received through port C.
m	\$CON D	CON	A \$CONNECT signal has been received through port D.
n	DA ERR1	ONC	Operation not complete. Processor/system controller interface sequence error 1 has been detected. (\$DATA-AVAIL received with no prior \$INTERRUPT sent.)
o	DA ERR2	ONC	Operation not completed. Processor/system controller interface sequence error 2 has been detected. (Multiple \$DATA-AVAIL received or \$DATA-AVAIL received out of order.)
	IAA		Coded illegal action, port A. (See Table 3-2)
	IAB		Coded illegal action, port B. (See Table 3-2)
	IAC		Coded illegal action, port C. (See Table 3-2)
	IAD		Coded illegal action, port D. (see Table 3-2)
p	CPAR DIR	None	A parity error has been detected in the cache memory directory.
q	CPAR STR	PAR	A data parity error has been detected in the cache memory.

<u>Flag or key</u>	<u>register</u>	<u>Fault</u>	<u>Function</u>
r	CPAR IA	PAR	An illegal action has been received from a system controller during a store operation with cache memory enabled. This implies that the data are correct in cache memory and incorrect in main memory.
s	CPAR BLK	PAR	A cache memory parity error has occurred during a cache memory data block load.
t		None	Cache Duplicate Directory WNO Buffer Overflow Port A
u		None	Port B
v		None	Port C
w		None	Port D
x		None	Cache Primary Directory WNO Buffer Overflow
y		None	Write Notify (WNO) Parity Error on Port A, B, C, or D.
z		None	Cache Duplicate Directory Parity Error Level 0
A		None	Level 1
B		None	Level 2
C		None	Level 3
D			Cache Duplicate Directory Multiple Match
E		None	A parity error has been detected in the SDWAM.
F		None	A parity error has been detected in the PTWAM.

MODE REGISTER (MR) - DPS and L68

Format: - 33 bits

Even word of Y-pair as stored by Store Central Processor Register (scpr), TAG = 06

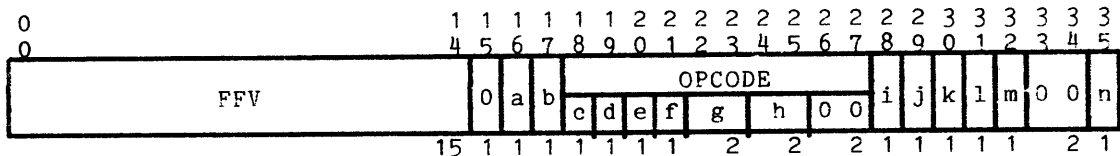

Figure 3-20. Mode Register (MR) Format - DPS and L68

Description:

An assemblage of flags and registers from the control unit. The Mode Register and the Cache Mode Register are both stored into the Y-pair by the Store Central Processor Register (scpr), TAG = 06. The Mode Register is loaded with the Load Central Processor Register (lcpr), TAG = 04, instruction.

Function:

The Mode Register controls the operation of those features of the processor that are capable of being enabled and disabled.

The functions of the constituent flags and registers are:

<u>Flag or key</u>	<u>register</u>	<u>Function</u>
	FFV	A floating-fault vector address. The 15 high-order bits of the Y-block8 address of four word pairs constituting a floating-fault vector. Traps to these floating faults are generated by other conditions the mode register sets.
a	OC TRAP	Trap on OPCODE match. If this bit is set ON and OPCODE matches the operation code of the instruction for which an address is being prepared (including indirect cycles), generate the second floating fault (xed FFV+2). See NOTE below.
b	ADR TRAP	Trap on ADDRESS match. If this bit is set ON and the computed address (TPR.CA) matches the setting of the address switches on the processor maintenance panel, generate the fourth floating fault (xed FFV+6). See NOTE below.
	OPCODE	The operation code on which to trap if OC TRAP (bit 16, key a) is set ON or for which to strobe all control unit cycles into the control unit history registers if O.C\$ l (bit 29, key j) is set ON.

or

Processor conditions codes as follows if OC TRAP (bit 16, key a) and O.C\$~~l~~ (bit 29, key j) are set OFF and ~~l~~ VOLT (bit 32, key m) is set ON.

Key Condition

- c Set control unit overlap inhibit if set ON. The control unit waits for the operations unit to complete execution of the even instruction of the current instruction pair before it begins address preparation for the associated odd instruction. The control unit also waits for the operations unit to complete execution of the odd instruction before it fetches the next instruction pair.
- d Set store overlap inhibit if set ON. The control unit waits for completion of a current main memory fetch (read cycles only) before requesting a main memory access for another fetch.
- e Set store incorrect data parity if set ON. The control unit causes incorrect data parity to be sent to the system controller for the next store instruction and then resets bit 20.
- f Set store incorrect zone-address-command (ZAC) parity if set ON. The control unit causes incorrect zone-address-command (ZAC) parity to be sent to the system controller for each main memory cycle of the next store instruction and resets bit 21 at the end of the instruction.

Flag or
key register

Function

Key Condition

- g Set timing margins if set ON. If ϵ VOLT (bit 32, key m) is set ON and the margin control switch on the processor maintenance panel is in PROG position, set processor timing margins as follows:

<u>22,23</u>	<u>Margin</u>
0,0	normal
0,1	slow
1,0	normal
1,1	fast

- h Set +5 voltage margins if set ON. If ϵ VOLT (bit 32, key m) is set ON and the margin control switch on the processor maintenance panel is in the PROG position, set +5 voltage margins as follows:

<u>24,25</u>	<u>Margin</u>
0,0	normal
0,1	low
1,0	high
1,1	normal

- i Trap on control unit history register count overflow if set ON. If this bit and STROBE ϵ (bit 30, key k) are set ON and the control unit history register counter overflows, generate the third floating fault (xed FFV+4). Further, if FAULT RESET (bit 31, key l) is set, reset STROBE ϵ (bit 30, key k), locking the history registers. A Load Central Processor Register (lcpr), TAG = 04, instruction setting bit 28 ON resets the control unit history register counter to zero. (See NOTE below.)
- j O.C ϵ Strobe control unit history registers on OPCODE match. If this bit and STROBE ϵ (bit 30, key k) are set ON and the operation code of the current instruction matches OPCODE, strobe the control unit history registers on all control unit cycles (including indirect cycles).
- k STROBE ϵ Enable history registers. If this bit is set ON, all history registers are strobed at appropriate points in the various processor cycles. If this bit is set OFF or MR ENABLE (bit 35, key n) is set OFF, all history registers are locked. This bit is set OFF with a Load Central Processor Register (lcpr), TAG = 04, instruction providing a 0 bit, by an operation not complete fault, and, conditionally, by other faults (see FAULT RESET (bit 31, key l) below). Once set OFF, this bit must be set ON with a Load Central Processor Register (lcpr), TAG = 04, instruction providing a 1 bit to re-enable the history registers.
- l FAULT RESET History register lock control. If this bit is set ON, set STROBE ϵ (bit 30, key k) OFF, locking the history registers for all faults including the floating faults. See NOTE below.
- m ϵ VOLT Test mode indicator. This bit is set ON whenever the TEST/NORMAL switch on the processor maintenance panel is in TEST position; otherwise, it is set OFF. It serves

Flag or
key register

Function

to enable the program control of voltage and timing margins.

n MR ENABLE

Enable mode register. When this bit is set ON, all other bits and controls of the mode register are active. When this bit is set OFF, the mode register controls are disabled.

NOTE: The traps described above (address match, OPCODE match, control unit history register counter overflow) occur after completion of the next odd instruction following their detection. They are handled as Group 7 faults in regard to servicing and inhibition. (See Section 7 for descriptions of these faults.) The complete Group 7 priority sequence (in increasing order) is:

- 1 - Connect
- 2 - Time runout
- 3 - Shutdown
- 4 - OPCODE trap
- 5 - Control unit history register counter overflow
- 6 - Address match trap
- 7 - External interrupts

MODE REGISTER (MR) - DPS 8M

Format: - 36 bits

Even word of Y-pair as stored by Store Central Processor Register (scpr), TAG = 06

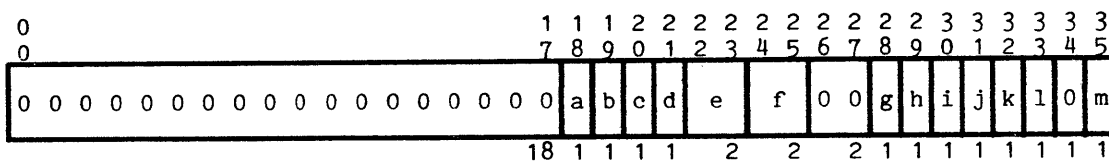

Figure 3-21. Mode Register (MR) Format - DPS 8M

Description:

An assemblage of flags and registers from the control unit. The Mode Register and the Cache Mode Register are both stored into the Y-pair by the Store Central Processor Register (scpr), TAG = 06. The Mode Register is loaded with the Load Central Processor Register (lcpr), TAG = 04, instruction.

Function:

The mode register controls the operation of those features of the processor that are capable of being enabled and disabled.

The functions of the constituent flags and registers are:

<u>Flag or key register</u>	<u>Function</u>										
a cuolin	Set CU overlap inhibit. The CU waits for the OU to complete execution of the even instruction before it begins address preparation for the associated odd instruction. The CU also waits for the OU to complete execution of the odd instruction before it fetches the next instruction pair.										
b solin	Set store overlap inhibit. The CU waits for completion of a current memory fetch (read cycles only) before requesting a memory access for another fetch.										
C sdpap	Set store incorrect data parity. The CU causes incorrect data parity to be sent to the SC for the next data store instruction and then resets bit 20.										
d separ	Set store incorrect ZAC parity. The CU causes incorrect zone-address-command (ZAC) parity to be sent to the SC for each memory cycle of the next data store instruction and resets bit 21 at the end of the instruction.										
e tm	Set timing margins. If bit 32 key (K) is set and the margin control switch on the CPU maintenance panel is in program position, set CPU timing margins as follows: <table border="1" data-bbox="711 974 932 1100"> <thead> <tr> <th><u>22,23</u></th> <th><u>margin</u></th> </tr> </thead> <tbody> <tr> <td>0,0</td> <td>normal</td> </tr> <tr> <td>0,1</td> <td>slow</td> </tr> <tr> <td>1,0</td> <td>normal</td> </tr> <tr> <td>1,1</td> <td>fast</td> </tr> </tbody> </table>	<u>22,23</u>	<u>margin</u>	0,0	normal	0,1	slow	1,0	normal	1,1	fast
<u>22,23</u>	<u>margin</u>										
0,0	normal										
0,1	slow										
1,0	normal										
1,1	fast										
f vm	Set +5 voltage margins. If bit 32 (key K) is set and the margin control switch on the CPU maintenance panel is in the program position, set +5 voltage margins as follows: <table border="1" data-bbox="711 1251 932 1377"> <thead> <tr> <th><u>24,25</u></th> <th><u>margin</u></th> </tr> </thead> <tbody> <tr> <td>0,0</td> <td>normal</td> </tr> <tr> <td>0,1</td> <td>low</td> </tr> <tr> <td>1,0</td> <td>high</td> </tr> <tr> <td>1,1</td> <td>normal</td> </tr> </tbody> </table>	<u>24,25</u>	<u>margin</u>	0,0	normal	0,1	low	1,0	high	1,1	normal
<u>24,25</u>	<u>margin</u>										
0,0	normal										
0,1	low										
1,0	high										
1,1	normal										
g hrhlt	Stop HR Strobe on HR Counter Overflow. (Setting bit 28 shall cause the HR counter to be reset to zero.)										
h hrxfr	Strobe the HR on Transfer Made. If bits 29,30, and 35 are = 1, the HR will be strobed on all Transfers Made. Bits 36-53 of the OU/DU register will indicate the "From" location and bits 36-59 of the CU register will contain the real address of the final "To" location.										
i ihr	Enable History Registers. If bit 30 = 1, the HRs may be strobed. If bit 30 = 0 or bit 35 = 0, they will be locked out. This bit will be reset by either an LCPR with the bit corresponding to 30 = 0 or by an Op Not Complete fault. It may be reset by other faults (see bit 31). After being reset, it must be enabled by another LCPR instruction before the History Registers may be strobed again.										

<u>key</u>	<u>Flag or register</u>	<u>Function</u>
j	ihrrs	Additional resetting of bit 30. If bit 31 = 1, the following faults also reset bit 30: <ul style="list-style-type: none"> - Lock Up - Parity - Command - Store - Illegal Procedure - Shutdown
k	mrgctl	Margin Control. Bit 32 informs the software when it can control margins. A one indicates that software has control. When the LOCAL/REMOTE switch on the power supply is in REMOTE and bit 35 = 1, bit 32 is set to 1 by occurrence of the following conditions: the NORMAL/TEST switch is in the TEST position, the Memory and CU Overlap Inhibit switches are OFF, the Timing Margins for the OU, CU, DU and VU are NORMAL, and the Forced Data and ZAC Parity are OFF.
l	hexfp	Hexadecimal Exponent Floating Point Arithmetic Mode can be set. When this bit is set, the Hex mode becomes effective when the Indicator Register bit 32 is set to 1.
m	emr	Enable Mode Register. Unless bit 35 = 1, all other bits in the Mode Register are ignored and the History Register is ignored and locked.

CACHE MODE REGISTER (CMR) - DPS and L68

Format: - 28 bits

Odd word of Y-pair as stored by Store Central Processor Register (scpr), TAG = 06

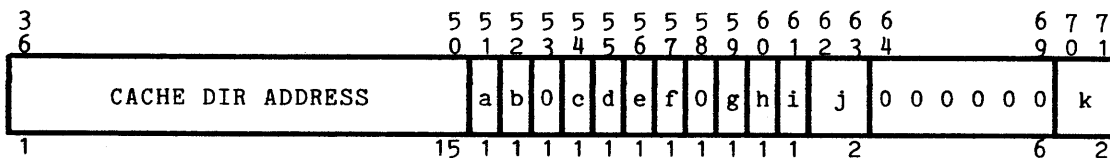

Figure 3-22. Cache Mode Register (CMR) Format - DPS and L68

Description:

An assemblage of flags and registers from the control unit. The Mode Register and Cache Mode Register are both stored into the Y-pair by the Store Central Processor Register (scpr), TAG = 06, instruction. The Cache Mode Register is loaded with the Load Central Processor Register (lcpr), TAG = 02, instruction.

The data stored from the cache mode register is address-dependent. The algorithm used to map main memory into the cache memory (see Section 9) is effective for the Store Central Processor Register (scpr) instruction. In general, the user may read out data from the directory entry for any cache memory block by proper selection of certain subfields in the 24-bit absolute main memory address. In particular, the user may read out the directory entry for the cache memory block involved in a suspected cache memory error by ensuring that the required 24-bit absolute main memory address subfields are the same as those for the access which produced the suspected error.

The fault handling procedure(s) should be unencacheable (SDW.C = 0) and the history registers and cache memory should be disabled as quickly as possible in order that vital information concerning the suspected error not be lost.

Function:

The Cache Mode register provides configuration information and software control over the operation of the cache memory. Those items with an "x" in the column headed L are not loaded by the Load Central Processor Register (lcpr), TAG = 02, instruction.

The functions of the constituent flags and registers are:

<u>key</u>	<u>L</u>	<u>Register</u>	<u>Function</u>
	x	CACHE DIR ADDRESS	15 high-order bits of the cache memory block address from the cache directory.
a	x	PAR BIT	Cache memory directory parity bit.
b	x	LEV FUL	The selected column and level is loaded with active data.
c		CSH1 ON	Enable the upper 1024 words of the cache memory (see Section 9).
d		CSH2 ON	Enable the lower 1024 words of the cache memory (see Section 9).
e		OPND ON	Enable the cache memory for operands (see Section 9).
f		INST ON	Enable the cache memory for instructions (see Section 9).
g		CSH REG	Enable cache-to-register (dump) mode. When this bit is set ON, double-precision operations unit read operands (e.g., Load AQ (ldaq) operands) are read from the cache memory according to the mapping algorithm and without regard to matching of the full 24-bit absolute main memory address. All other operands address main memory as though the cache memory were disabled. This bit is reset automatically by the hardware for any fault or interrupt.
h	x	STR ASD	Enable store aside. When this bit is set ON, the processor does not wait for main memory cycle completion after a store operation but proceeds after the cache memory cycle is complete.
i	x	COL FUL	Selected cache memory column is full.
j	x	RRO A,B	Cache round robin counter (see Section 9).
k		LUF MSB,LSB	Lockup timer setting. The lockup timer may set to four different values according to the value of this field.

key L Register

Function

<u>LUF value</u>	<u>Lockup time</u>
0	2ms
1	4ms
2	8ms
3	16ms

The lockup timer is set to 16ms when the processor is initialized.

CACHE MODE REGISTER (CMR) - DPS 8M

Format: - 36 bits

Odd word of Y-pair as stored by Store Central Processor Register (scpr), TAG = 06.

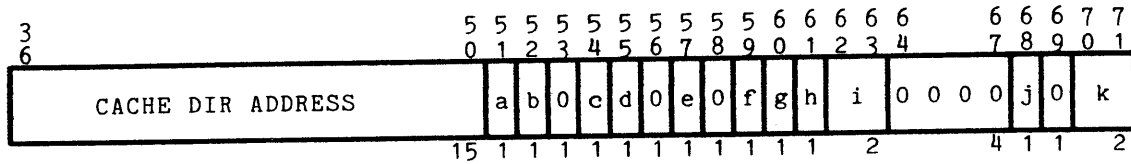

Figure 3-23. Cache Mode Register (CMR) Format - DPS 8M

Description:

An assemblage of flags and registers from the control unit. The Mode Register and Cache Mode Register are both stored into the Y-pair by the Store Central Processor Register (scpr), TAG = 06, instruction. The Cache Mode Register is loaded with the Load Central Processor Register (lcp), TAG = 02, instruction.

The data stored from the Cache Mode register is address-dependent. The algorithm used to map main memory into the cache memory (see Section 9) is effective for the Store central Processor Register (scpr) instruction. In general, the user may read out data from the directory entry for any cache memory block by proper selection of certain subfields in the 24-bit absolute main memory address. In particular, the user may read out the directory entry for the cache memory block involved in a suspected cache memory error by ensuring that the required 24-bit absolute main memory address subfields are the same as those for the access which produced the suspected error.

The fault handling procedure(s) should be unencacheable (SDW.D = 0) and the history registers and cache memory should be disabled as quickly as possible in order that vital information concerning the suspected error not be lost.

Function:

The Cache Mode Register provides configuration information and software control over the operation of the cache memory. Those items with an "x" in the column headed L are not loaded by the Load Central Processor Register (lcp_r), TAG = 02, instruction.

The functions of the constituent flags and registers are:

<u>key</u>	<u>L</u>	<u>Register</u>	<u>Function</u>
	x	CACHE DIR ADDRESS	15 high-order bits of the cache memory block address from the cache directory.
a	x	PAR BIT	Cache memory directory parity bit.
b	x	LEV FUL	The selected column and level is loaded with active data.
c		CSH1 ON	Enable the upper 4096 words of the cache memory (see Section 9).
d		CSH2 ON	Enable the lower 4096 words of the cache memory (see Section 9).
e		INST ON	Enable the cache memory for instructions (see Section 9).
f		CSH REG	Enable cache-to-register (dump) mode. When this bit is set ON, double-precision operations unit read operands (e.g., Load AQ (lda _q) operands) are read from the cache memory according to the mapping algorithm and without regard to matching of the full 24-bit absolute main memory address. All other operands address main memory as though the cache memory were disabled. This bit is reset automatically by the hardware for any fault or interrupt.
g	x	STR ASD	Enable store aside. When this bit is set ON, the processor does not wait for main memory cycle completion after a store operation but proceeds after the cache memory cycle is complete.
h	x	COL FUL	Selected cache memory column is full.
i	x	RRO A,B	Cache round-robin counter (see Section 9).
j			Bypass cache bit. Enables the bypass option of SDW.C when set OFF. See Notes below for further information.
k		LUF MSB,LSB	Lockup timer setting. The lockup timer may set to four different values according to the value of this field.

<u>LUF</u> <u>value</u>	<u>Lockup</u> <u>time</u>
0	2ms
1	4ms
2	8ms
3	16ms

The lockup timer is set to 16ms when the processor is initialized.

Notes

1. The COL FUL, RRO A, RRO B, and CACHE DIR ADDRESS fields reflect different locations in cache depending on the final (absolute) address of the sepr instruction storing this data.
2. If either cache enable bit c or d changes from disable state to enable state, the entire cache is cleared.
3. The DPS 8M processors contain an 8k hardware-controlled cache memory. When running a mixed configuration of DPS 8M and DPS/L68 processors, bit 68 of the cmr (reference j) allows the DPS 8M processor to utilize software compatible with the older 2k software controlled by the DPS/L68 and DPS processors. The following summarizes the operation of the DPS 8M hardware-controlled cache.
 - a. The cache bypass option in the segment descriptor word is retained. An overriding bypass enable, bit 68 of the Cache Mode Register, is added. The cache mode is set as follows:

SDW.C	CMR ₆₈	RESULTANT CACHE MODE
Use Cache	X	Use Cache
Bypass Cache	Bypass Cache	Bypass Cache
Bypass Cache	Use Cache	Use Cache

- b. All close gate instructions, LDAC, LDQC, STAC, STACQ, and SZNC automatically bypass cache. Two features are added to ensure integrity of gated shared data; one is added during the close gate operation and the other during the open gate operation. The instruction following the close gate instruction bypasses cache if the instruction is a Read or a Read-alter-rewrite. The open gate operation must be performed with either a STC2 or STACQ, which includes the synchronizing function. The synchronizing function forces the processor to delay the open gate operation until it is notified by the SCU that write completes have occurred and write notifications requesting cache block clears have been sent to the other processors for all write instructions that the processor previously issued.
- c. Read-alter-rewrite instructions no longer automatically bypass cache. Cache behavior for these instructions is determined fully by SDW.C. If the bypass cache mode is set, these instructions bypass cache and issue read-lock-write-unlock commands to memory. If a cache directory match occurs, the location is cleared.
- d. All accesses to memory by SDW and PTW associative memory hardware continue to bypass cache. Operations are Reads for SDWs, Read-alter-rewrites with lock for PTWs and setting the page Used bit, and Writes for setting the page Modified and Used bits. For Writes, the hardware also disables the key line so that the SCU lock is honored. This is consistent with dynamic PTW modification by software, which also bypasses cache and uses Read-alter-rewrite instructions.
- e. The instructions that cleared the associative memories and also cleared cache or selective portions of cache are changed to eliminate the cache clear function. Bit C (TPR.CA)¹⁵, is ignored. These instructions also include disable/enable capabilities for each half of the associative memories.

- f. Cache mode register bit 56, which had previously controlled cache bypass for operands, is disregarded. All other cache control bits are continued. However, maintenance panel cache control function is restricted to cache half enable/disable functions.

CONTROL UNIT (CU) HISTORY REGISTERS - DPS and L68

The L68 and DPS processors have four sets of 16 history requests. There is one set for each major unit: the Control Unit, CU; the Operations Unit, OU; the Decimal Unit, DU; and the Appending Unit, APU. The DPS 8M Processor has four sets of 64 history registers. There is one set for the CU, two sets for the APU, and one set that combines the history of the OU and DU.

Because the history registers for the L68 and DPS and the DPS 8M are different in number and content, they are described separately. The following section describes the L68 and DPS history registers first, followed by a description of the DPS 8M history registers.

Format: - 72 bits each

Even word of Y-pair as stored by Store Central Processor Register (scpr), TAG = 20

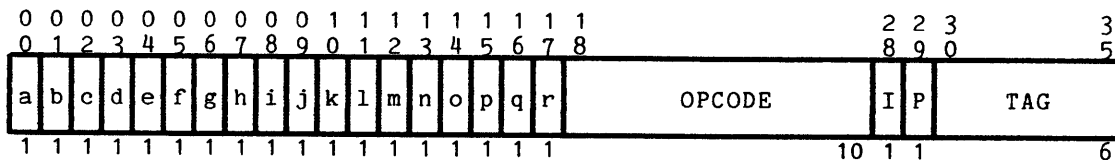

Odd word of Y-pair as stored by Store Central Processor Register (scpr), TAG = 20

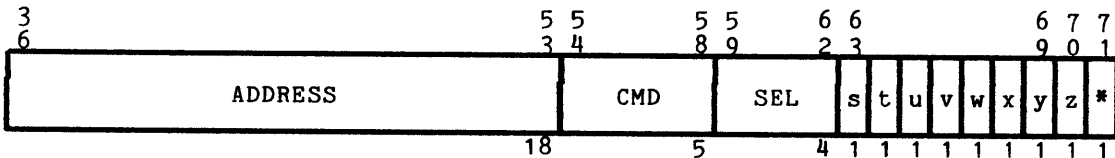

Figure 3-24. Control Unit (CU) History Register Format - DPS and L68

Description:

A combination of 16 flags and registers from the control unit. The 16 registers are handled as a rotating queue controlled by the Control Unit History Register counter. The counter is always set to the number of the oldest entry and advances by one for each history register reference (data entry or Store Central Processor Register (scpr) instruction). Multicycle instructions (such as Load Pointer Registers from ITS Pairs (lpri), Load Registers (lreg), Restore Control Unit (rcu), etc.) have an entry for each of their cycles.

Function:

A control unit history register entry shows the conditions at the end of the control unit cycle to which it applies. The 16 registers hold the conditions for the last 16 control unit cycles. Entries are made according to controls set in the Mode Register. (See Mode Register earlier in this section.)

The meanings of the constituent flags and registers are:

<u>key</u>	<u>Flag Name</u>	<u>Meaning</u>
a	PIA	Prepare instruction address
b	POA	Prepare operand address
c	RIW	Request indirect word
d	SIW	Restore indirect word
e	POT	Prepare operand tally (indirect tally chain)
f	PON	Prepare operand no tally (as for POT except no chain)
g	RAW	Request read-alter-rewrite word
h	SAW	Restore read-alter-rewrite word
i	TRGO	Transfer GO (conditions met)
j	XDE	Execute even instruction from Execute Double (xed) pair
k	XDO	Execute odd instruction from Execute Double (xed) pair
l	IC	Execute odd instruction of the current pair
m	RPTS	Execute a repeat instruction
n	WI	Wait for instruction fetch
o	AR F/E	1 = ADDRESS has valid data
p	\overline{XIP}	NOT prepare interrupt address
q	\overline{FLT}	NOT prepare fault address
r	\overline{BASE}	NOT BAR mode
	OPCODE	Operation code from current instruction word
	I	Interrupt inhibit bit from current instruction word
	P	Pointer register flag bit from current instruction word
	TAG	Current address modifier. This modifier is replaced by the contents of the TAG fields of indirect words as they are fetched during indirect chains.
	ADDRESS	Current computed address (TPR.CA)
	CMD	System controller command
	SEL	Port select bits. (Valid only if port A-D is selected)
s	XEC-INT	An interrupt is present
t	INS-FETCH	Perform an instruction fetch

<u>key</u>	<u>Flag Name</u>	<u>Meaning</u>
u	CU-STORE	Control unit store cycle
v	OU-STORE	Operations unit store cycle
w	CU-LOAD	Control unit load cycle
x	OU-LOAD	Operations unit load cycle
y	DIRECT	Direct cycle
z	$\overline{\text{PC-BUSY}}$	Port control logic not busy
*	BUSY	Port interface busy

CONTROL UNIT (CU) HISTORY REGISTERS - DPS 8M

Format: - 72 bits each

Even word of Y-pair as stored by Store Central Processor Register (scpr), TAG = 20

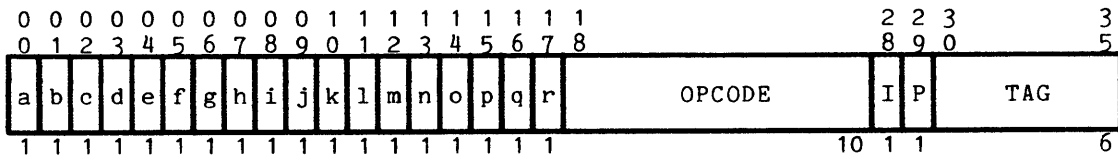

Odd word of Y-pair as stored by Store Central Processor Register (scpr), TAG = 20

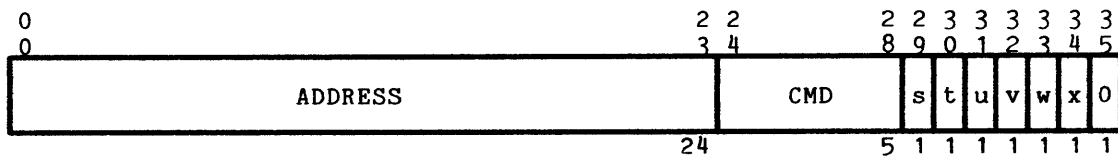

Figure 3-25. Control Unit (CU) History Register Format - DPS 8M

Description:

A combination of 64 flags and registers from the control unit. The 64 registers are handled as a rotating queue, controlled by the control unit history register counter, in which only the 16 most recently used are stored (except in the event of a system crash in which case all 64 will be saved). The counter is always set to the number of the oldest entry and advances by one for each history register reference (data entry or Store Central Processor Register (scpr) instruction). Multicycle instructions (such as Load Pointer Registers from ITS Pairs (lpri), Load Registers (lreg), Restore Control Unit (rcu), etc.) have an entry for each of their cycles.

Function:

A control unit history register entry shows the conditions at the end of the control unit cycle to which it applies. The 16 registers hold the conditions for the last 16 control unit cycles. Entries are made according to controls set in the Mode Register. (See Mode Register earlier in this section.)

The meanings of the constituent flags and registers are:

<u>key</u>	<u>Flag Name</u>	<u>Meaning</u>
a	PIA	Prepare instruction address
b	POA	Prepare operand address
c	RIW	Request indirect word
d	SIW	Restore indirect word
e	POT	Prepare operand tally
f	PON	Prepare operand no tally
g	RAW	Request read-alter-rewrite word
h	SAW	Restore read-alter-rewrite word
i	RTRGO	Remember transfer GO (condition met)
j	XDE	XED from even location
k	XDO	XED from odd location
l	IC	Even/odd instruction pair
m	RPTS	Repeat operation
n	PORTF	Memory cycle to port on previous cycle
o	INTERNAL	Memory cycle to cache or direct on previous cycle
p	PAI	Prepare interrupt address
q	PFA	Prepare fault address
r	PRIV	In privileged mode
	OPCODE	Opcode of instruction
	I	Inhibit interrupt bit
	P	AR reg mod flag
	TAG	Tag field of instruction
	ADDRESS	Absolute mean address of instruction
	CMD	Processor command register
s	XINT	Execute instruction
t	IFT	Instruction fetch
u	CRD	Cache read, this CU cycle
v	MRD	Memory read, this CU cycle

<u>key</u>	<u>Flag Name</u>	<u>Meaning</u>
w	MSTO	Memory store, this CU cycle
x	PIB	Memory port interface busy

OPERATIONS UNIT (OU) HISTORY REGISTERS

Format: - 72 bits each

Even word of Y-pair as stored by Store Central Processor Register (scpr), TAG = 40

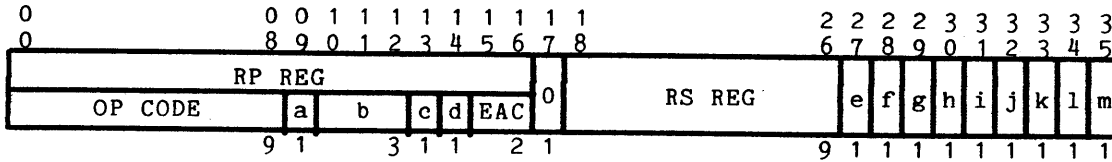

Odd word of Y-pair as stored by Store Central Processor Register (scpr), TAG = 40

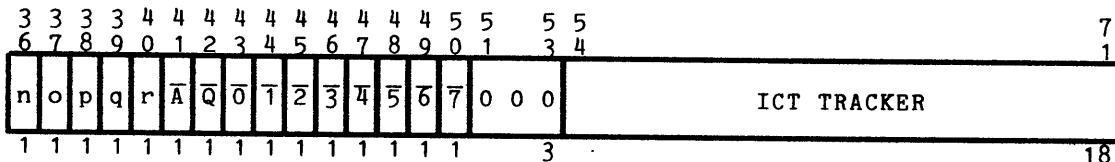

Figure 3-26. Operations Unit (OU) History Register Format

Description:

A combination of 16 flags and registers from the operation unit and control unit. The 16 registers are handled as a rotating queue controlled by the operations unit history register counter. The counter is always set to the number of the oldest entry and advances by one for each history register reference (data entry or Store Central Processor Register (scpr) instruction).

Function:

An Operations Unit History Register entry shows the conditions at the end of the operations unit cycle to which it applies. The 16 registers hold the conditions for the last 16 operations unit cycles. As the operations unit performs various cycles in the execution of an instruction, it does not advance the counter for each such cycle. The counter is advanced only at successful completion of the instruction or if the instruction is aborted for a fault condition. Entries are made according to controls set in the Mode Register. (See Mode Register earlier in this section.)

The meanings of the constituent flags and registers are:

<u>key</u>	<u>Flag Name</u>	<u>Meaning</u>
	RP REG	Primary operations unit operation register. RP REG receives the operation code and other data for the next instruction from the control unit during the control unit instruction fetch cycle while the operations unit may be busy with a prior instruction. RP REG is further substructured as:
	OP CODE	The 9 high-order bits of the 10-bit operation code from the instruction word. Note that basic (non EIS) instructions do not involve bit 27 hence the 9-bit field is sufficient to determine the instruction.
a	9 CHAR	Character size for indirect then tally address modifiers 0 = 6-bit 1 = 9-bit
b	TAG1,2,3	The 3 low-order bits of the address modifier from the instruction word. This field <u>may</u> contain a character position for an indirect then tally address modifier.
c	CR FLG	Character operation flag
d	DR FLG	Direct operation flag
	EAC	Address counter for lreg/sreg instructions
	RS REG	Secondary operations unit operation register. OP CODE is moved from RP REG to RS REG during the operand fetch cycle and is held until completion of the instruction.
e	RB1 FULL	OP CODE buffer is loaded
f	RP FULL	RP REG is loaded
g	RS FULL	RS REG is loaded
h	GIN	First cycle for all OU instructions
i	GOS	Second cycle for multicycle OU instructions
j	GD1	First divide cycle
k	GD2	Second divide cycle
l	GOE	Exponent compare cycle
m	GOA	Mantissa alignment cycle
n	GOM	General operations unit cycle
o	GON	Normalize cycle
p	GOF	Final operations unit cycle
q	STR OP	Store (output) data available
t	<u>DA-AV</u>	Data not available
\bar{A}	<u>A-REG</u>	A register not in use
\bar{Q}	<u>Q-REG</u>	Q register not is use

<u>key</u>	<u>Flag Name</u>	<u>Meaning</u>
0	X0-RG	X0 not in use
1	X1-RG	X1 not in use
2	X2-RG	X2 not in use
3	X3-RG	X3 not in use
4	X4-RG	X4 not in use
5	X5-RG	X5 not in use
6	X6-RG	X6 not in use
7	X7-RG	X7 not in use
	ICT TRACKER	The current value of the instruction counter (PPR.IC). Since the Control Unit and Operations Unit run asynchronously and overlap is usually enabled, the value of ICT TRACKER may not be the address of the operations unit instruction currently being executed.

DECIMAL UNIT (DU) HISTORY REGISTERS - DPS and L68

Format: - 72 bits each

Decimal Unit History Register data is stored with the Store Central Processor Register (scpr), TAG = 10, instruction. There is no format diagram because the data is defined as individual bits.

Description:

A combination of 16 flags from the decimal unit. The 16 registers are handled as a rotating queue controlled by the decimal unit history register counter. The counter is always set to the number of the oldest entry and advances by one for each history register reference (data entry or Store Central Processor Register (scpr) instruction).

The decimal unit and the control unit run synchronously. There is a control unit history register entry for every decimal unit history register entry and vice versa (except for instruction fetch and EIS descriptor fetch cycles). If the processor is not executing a decimal instruction, the decimal unit history register entry shows an idle condition.

Function:

A decimal unit history register entry shows the conditions in the decimal unit at the end of the control unit cycle to which it applies. The 16 registers hold the conditions for the last 16 control unit cycles. Entries are made according to controls set in the Mode Register. (See Mode Register earlier in this section.)

A minus (-) sign preceding the flag name indicates that the complement of the flag is shown. Unused bits are set ON.

The meanings of the constituent flags are:

<u>bit</u>	<u>Flag Name</u>	<u>Meaning</u>
0	-FPOL	Prepare operand length
1	-FPOP	Prepare operand pointer
2	-NEED-DESC	Need descriptor
3	-SEL-ADR	Select address register
4	-DLEN=DIRECT	Length equals direct
5	-DFRST	Descriptor processed for first time
6	-FEXR	Extended register modification
7	-DLAST-FRST	Last cycle of DFRST
8	-DDU-LDEA	Decimal unit load
9	-DDU-STAE	Decimal unit store
10	-DREDO	Redo operation without pointer and length update
11	-DLVL<WD-SZ	Load with count less than word size
12	-EXH	Exhaust
13	DEND-SEQ	End of sequence
14	-DEND	End of instruction
15	-DU=RD+WRT	Decimal unit write-back
16	-PTRAO0	PR address bit 0
17	-PTRAO1	PR address bit 1
18	FA/I1	Descriptor 1 active
19	FA/I2	Descriptor 2 active
20	FA/I3	Descriptor 3 active
21	-WRD	Word operation
22	-NINE	9-bit character operation
23	-SIX	6-bit character operation
24	-FOUR	4-bit character operation
25	-BIT	Bit operation
26		Unused
27		Unused
28		Unused
29		Unused

30	FSAMPL	Sample for mid-instruction interrupt
31	-DFRST-CT	Specified first count of a sequence
32	-ADJ-LENGTH	Adjust length
33	-INTRPTD	Mid-instruction interrupt
34	-INHIB	Inhibit STC1 (force "STC0")
35		Unused
36	DUD	Decimal unit idle
37	-GDLDA	Descriptor load gate A
38	-GDLDB	Descriptor load gate B
39	-GDLDC	Descriptor load gate C
40	NLD1	Prepare alignment count for first numeric operand load
41	GLDP1	Numeric operand one load gate
42	NLD2	Prepare alignment count for second numeric operand load
43	GLDP2	Numeric operand two load gate
44	ANLD1	Alphanumeric operand one load gate
45	ANLD2	Alphanumeric operand two load gate
46	LDWRT1	Load rewrite register one gate
47	LDWRT2	Load rewrite register two gate
48	-DATA-AVLDU	Decimal unit data available
49	WRT1	Rewrite register one loaded
50	GSTR	Numeric store gate
51	ANSTR	Alphanumeric store gate
52	FSTR-OP-AV	Operand available to be stored
53	-FEND-SEQ	End sequence flag
54	-FLEN<128	Length less than 128
55	FGCH	Character operation gate
56	FANPK	Alphanumeric packing cycle gate
57	FEXMOP	Execute MOP gate
58	FBLNK	Blanking gate
59		Unused
60	DGBD	Binary to decimal execution gate
61	DGDB	Decimal to binary execution gate
62	DGSP	Shift procedure gate
63	FFLTG	Floating result flag

64	FRND	Rounding flag
65	DADD-GATE	Add/subtract execute gate
66	DMP+DV-GATE	Multiply/divide execution gate
67	DXPN-GATE	Exponent network execution gate
68		Unused
69		Unused
70		Unused
71		Unused

DECIMAL/OPERATIONS UNIT (DU/OU) HISTORY REGISTERS - DPS 8M

Format: - 72 bits each

Even word of Y-pair as stored by Store Central Processor Register (scpr),
TAG = 40

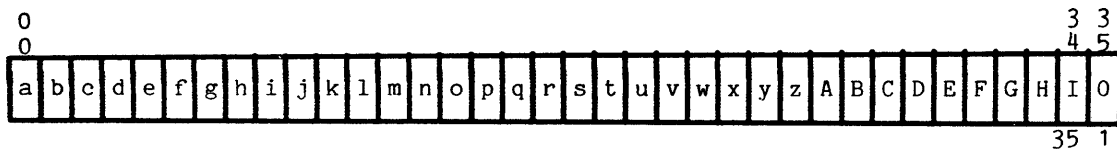

Odd word of Y-pair as stored by Store Central Processor Register (scpr),
TAG = 40

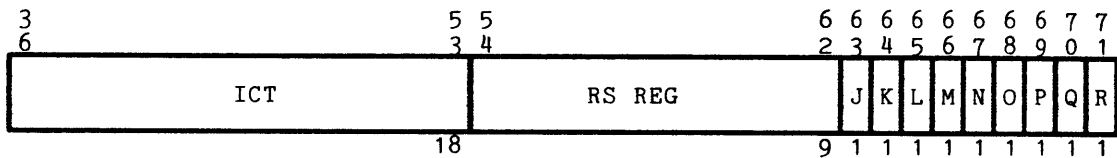

Figure 3-27. Decimal/Operations (DU/OU) History Register Format - DPS 8M

Description:

A combination of 16 flags and registers from the operation unit and decimal unit. The 16 registers are handled as a rotating queue controlled by the operations unit history register counter. The counter is always set to the number of the oldest entry and advances by one for each history register reference (data entry or Store Central Processor Register (scpr) instruction).

The decimal unit and the control unit run synchronously. There is a control unit history register entry for every decimal unit history register entry and vice versa (except for instruction fetch and EIS descriptor fetch cycles). If the processor is not executing a decimal instruction, the decimal unit history register entry shows an idle condition.

Function:

An operations unit history register entry shows the conditions at the end of the operations unit cycle to which it applies. The 16 registers hold the conditions for the last 16 operations unit cycles. As the operations unit performs various cycles in the execution of an instruction, it does not advance the counter for each such cycle. The counter is advanced only at successful completion of the instruction or if the instruction is aborted for a fault condition. Entries are made according to controls set in the Mode Register. (See Mode Register earlier in this section.)

The meanings of the constituent flags and registers are:

<u>key</u>	<u>Flag Name</u>	<u>Meaning</u>
a	FANLD1	Alpha-num load desc 1 (complemented)
b	FANLD2	Alpha-num load desc 2 (complemented)
c	FANSTR	Alpha-num store (complemented)
d	FLDWRT1	Load re-write reg 1 (complemented)
e	FLDWRT2	Load re-write reg 2 (complemented)
f	FNLD1	Numeric load desc 1 (complemented)
g	FNLD2	Numeric load desc 2 (complemented)
h	NOSEQF	End sequence flag
i	FDUD	Decimal unit idle (complemented)
j	FGSTR	General store flag (complemented)
k	NOSEQ	End of sequence (complemented)
l	NINE	9-bit character operation
m	SIX	6-bit character operation
n	FOUR	4-bit character operation
o	DUBIT	Bit operation
p	DUWORD	Word operation
q	PTR1	Select ptr 1
r	PTR2	Select ptr 2
s	PTR3	Select ptr 3
t	FPOP	Prepare operand pointer
u	GEAM	Add timing gates (complemented)
v	LPD12	Load pointer 1 or 2 (complemented)
w	GEMAE	Multiply gates A E (complemented)
x	BTDS	Binary to decimal gates (complemented)
y	SP15	Align cycles (complemented)
z	FSWEQ	Single word sequence flag (complemented)

<u>key</u>	<u>Flag Name</u>	<u>Meaning</u>
A	FGCH	Character cycle (complemented)
B	DFRST	Processing descriptor for first time
C	EXH	Exhaust
D	FGADO	Add cycle (complemented)
E	INTRPTD	Interrupted
F	GLDP2	Load DP2
G	GEMC	Multiply gate C
H	GBDA	Binary to decimal gate A
I	GSP5	Final align cycle
	ICT	Instruction counter (See NOTE below.)
	RS	OU op-code register (RS0-8)
IR		Indicator register (IR):
J	ZERO	Zero indicator
K	NEG	Negative indicator
L	CARRY	Carry indicator
M	OVFL	Overflow indicator
N	EOVFL	Exponent overflow indicator
O	EUFL	Exponent underflow indicator
P	OFLM	Overflow mask indicator
Q	HEX	Hex mode indicator
R	DTRGO	Transfer go

NOTE:

The current value of the instruction counter (PPR.IC). Since the control unit and operations unit run asynchronously and overlap is usually enabled, the value of ICT TRACKER may not be the address of the operations unit instruction currently being executed.

APPENDING UNIT (APU) HISTORY REGISTERS - DPS and L68

Format: - 72 bits each

Even word of Y-pair as stored by Store Central Processor Register (scpr),
TAG = 00

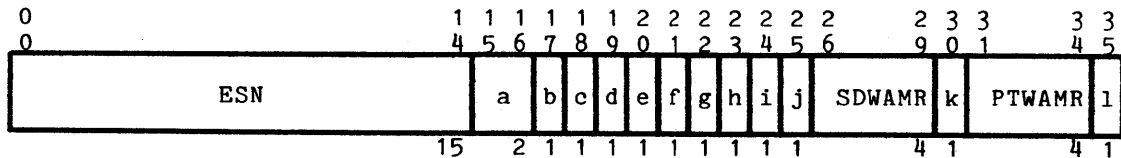

Odd word of Y-pair as stored by Store Central Processor Register (scpr),
TAG = 00

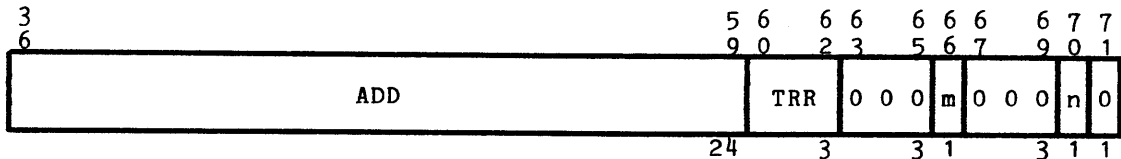

Figure 3-28. Appending Unit (APU) History Register Format - DPS and L68

Description:

A combination of 16 flags and registers from the appending unit. The 16 registers are handled as a rotating queue controlled by the appending unit history register counter. The counter is always set to the number of the oldest entry and advances by one for each history register reference (data entry or Store Central Processor Register (scpr) instruction).

Function:

An appending unit history register entry shows the conditions in the appending unit at the end of an address preparation cycle in appending mode. The 16 registers hold the conditions for the last 16 such address preparation cycles. Entries are made according to controls set in the Mode Register. (See Mode Register earlier in this section.)

The meanings of the constituent flags and registers are:

<u>key</u>	<u>Flag name</u>	<u>Meaning</u>
	ESN	Effective segment number (TPR.TSR)
a	BSY	Data source for ESN
		00 = from PPR.PSR
		01 = from PRn.SNR
		10 = from TPR.TSR
		11 = not used

<u>key</u>	<u>Flag name</u>	<u>Meaning</u>
b	FDSPTW	Descriptor segment PTW fetch
c	MDSPTW	Descriptor segment PTW modification
d	FSDWP	SDW fetch from paged descriptor segment
e	FPTW	PTW fetch
f	FPTW2	PTW+1 fetch (prepaging for certain EIS instructions)
g	MPTW	PTW modification
h	FANP	Final address fetch from nonpaged segment
i	FAP	Final address fetch from paged segment
j	SDWAMM	SDWAM match occurred
	SDWAMR	SDWAM register number if SDWAMM=1
k	PTWAMM	PTWAM match occurred
	PTWAMR	PTWAM register number if PTWAMM=1
l	FLT	Access violation or directed fault on this cycle
	ADD	24-bit absolute main memory address from this cycle
	TRR	Ring number from this cycle (TPR.TRR)
m		Multiple match error in SDWAM
n	CA	Segment is encacheable
p		Multiple match error in PTWAM
r	FHLD	An access violation or directed fault is waiting

APPENDING UNIT (APU) HISTORY REGISTERS - DPS 8M

Format: - 72 bits each

Even word of Y-pair as stored by Store Central Processor Register (scpr),
TAG = 00

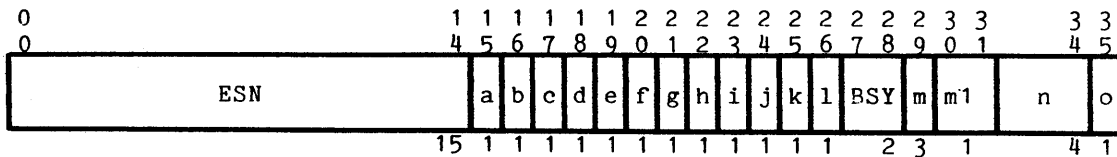

Odd word of Y-pair as stored by Store Central Processor Register (scpr),
TAG = 00

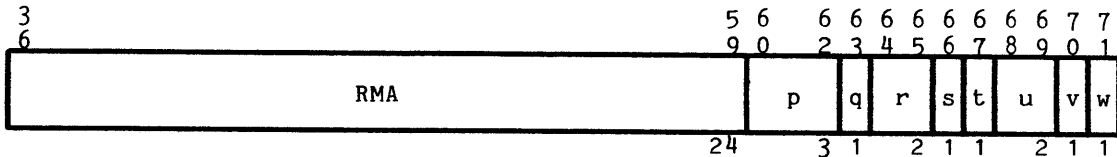

Extended APU History Register:

Even word of Y-pair as stored by Store Central Processor Register (scpr),
TAG = 10

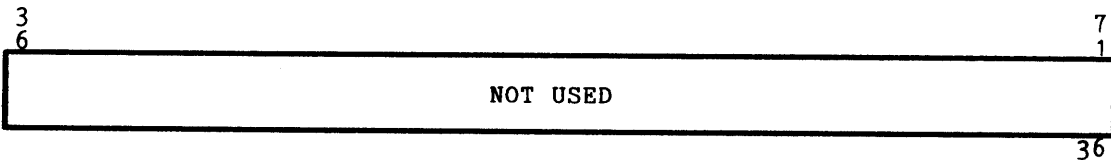
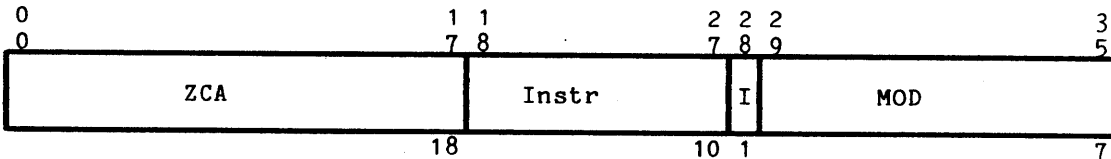

Figure 3-29. Appending Unit (APU) History Register Format - DPS 8M

Description:

A combination of 64 flags and registers from the appending unit. The 64 registers are handled as a rotating queue controlled by the appending unit history register counter. The counter is always set to the number of the oldest entry and advances by one for each history register reference (data entry or Store Central Processor Register (scpr) instruction).

Function:

An appending unit history register entry shows the conditions in the appending unit at the end of an address preparation cycle in appending mode. The 64 registers hold the conditions for the last 64 such address preparation cycles. Entries are made according to controls set in the Mode Register. (See Mode Register earlier in this section.)

The meanings of the constituent flags and registers are:

<u>key</u>	<u>Flag name</u>	<u>Meaning</u>
	ESN	Effective segment number
a		PIA Page overflow
b		PIA out of segment bounds
c	FDSPTW	Fetch descriptor segment FTW
d	MDSPTW	Descriptor segment PTW is modified
e	FSDW	Fetch SDW
f	FPTW	Fetch PTW
g	FPTW2	Fetch pre-page PTW
h	MPTW	PTW modified
i	FANP	Final address nonpaged
j	FAP	Final address paged
k	MTCHSDW	SDW match found
l	SDWMF	SDW match found and used
	BSY	Data source for ESN 00 = from ppr.ic 01 = from prn.tsr 10 = from tpr.swr 11 = from tpr.ca
m	MTCHPTW	PTW match found (AM)
m1	PTWMF	PTW match found (AM) and used
n	PTWAM	PTW AM direct address (ZCA bits 4-7)
o	SDWMF	SDW match found
	RMA	Read 24 bit memory address
p	RTRR	Temporary ring register
q	SDWME	SDW match error
r	SDWLVL	SDW match level count (0 = Level A)
s	CACHE	Cache used this cycle
t		PTW match error
u	PTWLVL	PTW match level count (0 = level A)

<u>key</u>	<u>Flag name</u>	<u>Meaning</u>
v	FLTHLD	A directed fault or access violation fault is waiting
	ZCA	Computed address
	INSTR	Instruction executed
I		Inhibit bit
	MOD	Instruction modifier

CONFIGURATION SWITCH DATA - DPS and L68

Format: - 36 bits each

Data read by Read Switches (rsw), y = xxxxx0

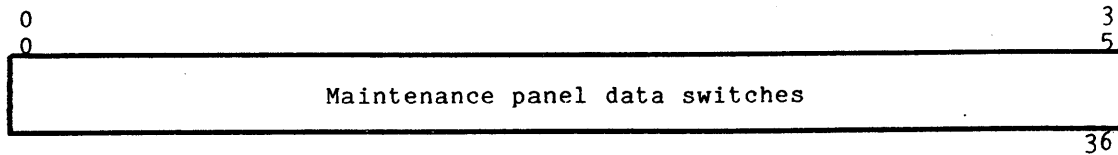

Data read by Read Switches (rsw), y = xxxxx2

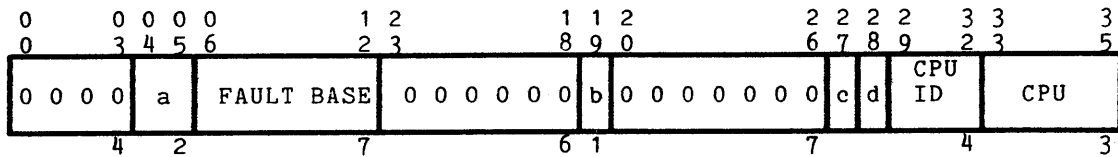

Data read by Read Switches (rsw), y = xxxxx1 (port A-D) or xxxxx3 (port E-H)

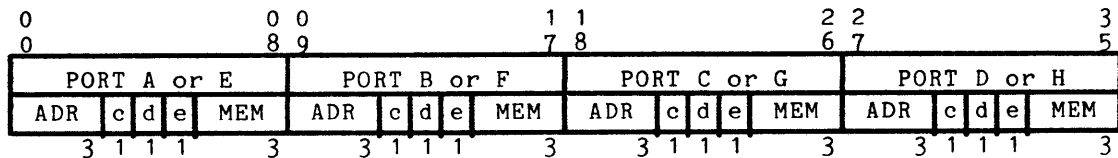

Data read by Read Switches (rsw), y = xxxxx4

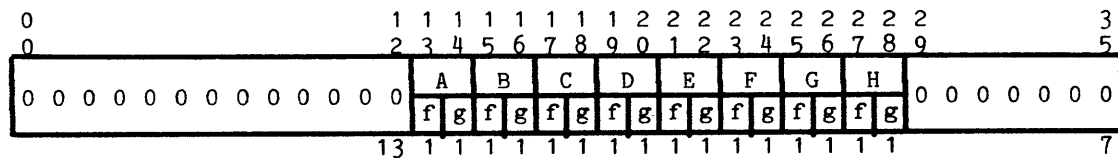

Figure 3-30. Configuration Switch Data Formats - DPS and L68

Description:

The Read Switches (rsw) instruction provides the ability to interrogate various switches and options on the processor maintenance and configuration panels. The 3 low-order bits of the computed address (TPR.CA) select the switches to be read. High-order address bits are ignored. Data are placed in the A Register.

Read Switches (rsw), y = xxxxx1 reads data for ports A, B, C, and D. Read Switches (rsw), y = xxxxx3 reads data for ports E, F, G, and H.

Function:

The meanings of the constituent fields are:

<u>key</u>	<u>Field name</u>	<u>Meaning</u>
a	CPU-Type	Equals "00" for a L68 or a DPS processor.
	FLT BASE	The seven MSB of the 12-bit fault base address
b	dps_option	Processor option 0 = L68 processor 1 = DPS processor
c	cache	2K cache option 0 = disabled 1 = enabled
d	ext_gcoss	GCOS mode extended memory option 0 = disabled 1 = enabled
	CPU_ID	These bit positions have a configuration of "1110"s for a L68 or a DPS CPU.
	CPU	Processor number from processor configuration panel number switches.
	PORT A or E, etc.	Port data fields further substructured as:
	ADR	Address assignment switch setting for port
c		Port enabled flag
d		System initialize enabled flag
e		Interlace enabled flag
	MEM	Coded memory size ...
		000 32K
		001 64K
		010 128K
		011 256K
		100 512K
		101 1024K
		110 2048K
		111 4096K
	A, B, etc.	Port data fields further substructured as:
f		Interlace mode 0 = 4 word if interlace enabled for port 1 = 2 word if interlace enabled for port
g		Main memory size 0 = full, all of MEM is configured 1 = half, half of MEM is configured

CONFIGURATION SWITCH DATA - DPS 8M

The following changes apply to the DPS 8M processor.

Format: - 36 bits each

Data read by Read Switches (rsw), y = xxxxx2

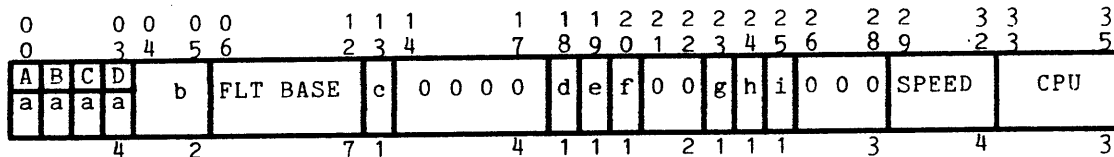

Data read by Read Switches (rsw), y = xxxxx1 (port A-D)

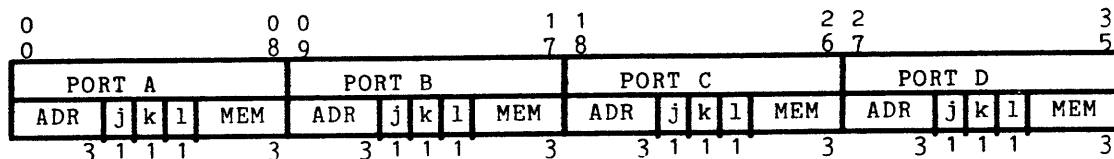

Figure 3-31. Configuration Switch Data Formats - DPS 8M

Description:

The Read Switches (rsw) instruction provides the ability to interrogate various switches and options on the processor maintenance and configuration panels. The two low-order bits of the computed address (TPR.CA) select the switches to be read. High-order address bits are ignored. Data are placed in the A Register.

Read Switches (rsw), y = xxxxx1 reads data for ports A, B, C, and D.

Function:

The meanings of the constituent fields are:

<u>key</u>	<u>Field name</u>	<u>Meaning</u>
a		If the corresponding rsw1 interface enabled flag, bit (e) is ON, then 0 = 4 word interfaces 1 = 2 word interfaces For ports A - D
b		Indicates processor type 00 = L68 or DPS Processor 01 = DPS 8M Processor 10 = reserved for future use 11 = reserved for future use

<u>key</u>	<u>Field name</u>	<u>Meaning</u>
	FLTBASE	The seven MSB of the 12-bit fault base address
c		ID prom 0 = id prom not installed 1 = id prom installed
d		BCD option (Marketing designation) 1 = BCD option installed
e		DPS option (Marketing designation) 1 = DPS option
f		8K cache 1 = 8K cache installed
g		DPS 8M Processor type designation 1 = DPS 8/xxM 0 = DPS 8/xx
h		GCOS/VMS switch position 1 = Virtual Mode 0 = GCOS Mode
i		Current or new product line peripheral type 1 = NPL 0 = CPL
	SPEED	Processor speed options 0000 = 8/70 0100 = 8/52
	CPU	Processor number
	ADR	
j		Port enabled flag
k		System initialize enabled flag
l		Interface enabled flag
	MEM	Coded memory size: 000 32K 001 64K 010 128K 011 256K 100 512K 101 1024K 110 2048K 111 4096K

CONTROL UNIT DATA

Format: - 288 bits, 8 machine words

Data as stored by Store Control Unit (scu) instruction

Word

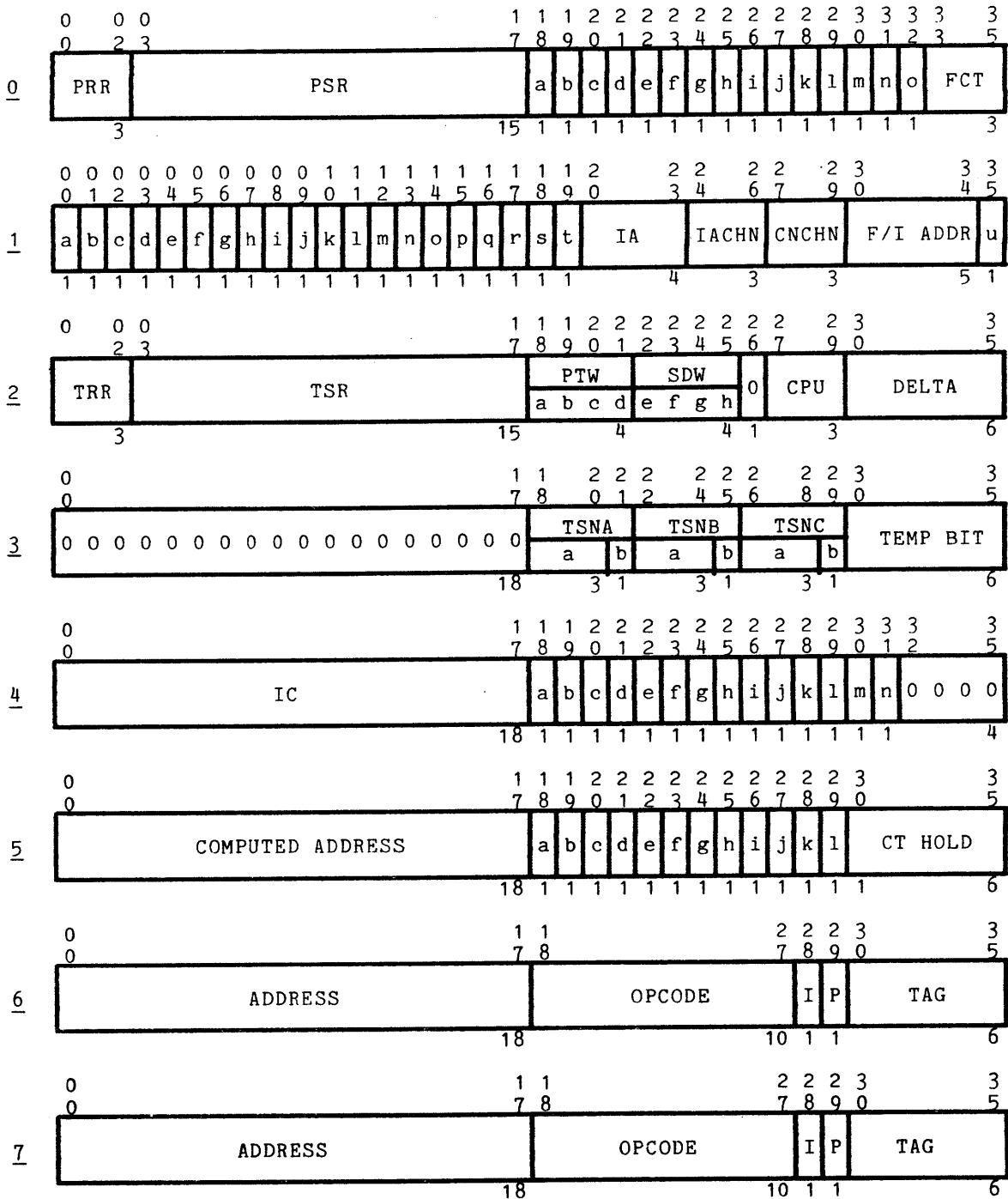

Figure 3-32. Control Unit Data Format

Description:

A collection of flags and registers from the appending unit and the control unit. In general, the data has valid meaning only when stored with the Store Control Unit (scu) instruction as the first instruction of a fault or interrupt trap pair.

Function:

The control unit data allows the processor to restart an instruction at the point of interruption when it is interrupted by an access violation fault, a directed fault, or (for certain EIS instructions) an interrupt. Directed faults are intentional, and most access violation faults and interrupts are recoverable. If the interruption is not recoverable, the control unit data provides enough information to determine the exact nature of the error.

Instruction execution restarts immediately upon execution of a Restore Control Unit (rcu) instruction referencing the Y-block8 area into which the control unit data was stored.

Fields having an "x" in the column headed L are not restored by the Restore Control Unit (rcu) instruction.

The meanings of the constituent fields are:

<u>Word</u>	<u>key</u>	<u>L</u>	<u>Field name</u>	<u>Meaning</u>
0			PRR	Procedure ring register (PPR.PRR)
0			PSR	Procedure segment register (PPR.PSR)
0	a		P	Privileged bit (PPR.P)
0	b		XSF	External segment flag
0	c	x	SDWAMM	Match on SDWAM
0	d	x	SD-ON	SDWAM enabled
0	e	x	PTWAMM	Match on PTWAM
0	f	x	PT-ON	PTWAM enabled
0	g	x	PI-AP	Instruction fetch append cycle
0	h	x	DSPTW	Fetch descriptor segment PTW
0	i	x	SDWNP	Fetch SDW - nonpaged
0	j	x	SDWP	Fetch SDW - paged
0	k	x	PTW	Fetch PTW
0	l	x	PTW2	Fetch prepage PTW
0	m	x	FAP	Fetch final address - paged
0	n	x	FANP	Fetch final address - nonpaged
0	o	x	FABS	Fetch final address - absolute
0			FCT	Fault counter - counts retries

<u>Word</u>	<u>key</u>	<u>L</u>	<u>Field</u> <u>name</u>	<u>Meaning</u>
1	a	x	IRO	For access violation fault - illegal ring order
		x	ISN	For store fault - illegal segment number
1	b	x	OEB	For access violation fault - out of execute bracket
		x	IOC	For illegal procedure fault - illegal op code
1	c	x	E-OFF	For access violation fault - execute bit is OFF
		x	IA+IM	For illegal procedure fault - illegal address or modifier
1	d	x	ORB	For access violation fault - out of read bracket
		x	ISP	For illegal procedure fault - illegal slave procedure
1	e	x	R-OFF	For access violation fault - read bit is OFF
		x	IPR	For illegal procedure fault - illegal EIS digit
1	f	x	OWB	For access violation fault - out of write bracket
		x	NEA	For store fault - nonexistent address
1	g	x	W-OFF	For access violation fault - write bit is OFF
		x	OOB	For store fault - out of bounds (BAR mode)
1	h	x	NO GA	For access violation fault - not a gate
1	i	x	OCB	For access violation fault - out of call bracket
1	j	x	OCALL	For access violation fault - outward call
1	k	x	BOC	For access violation fault - bad outward call
1	l	x	PTWAM_ER	For access violation fault - on DPS 8M processors, a PTW associative memory error. Not used on DPS/L68 processors.
1	m	x	CRT	For access violation fault - cross ring transfer
1	n	x	RALR	For access violation fault - ring alarm
1	o	x	SDWAM_ER	For access violation fault - On DPS 8M an SDW associative memory error. An associative memory error on DPS/L68.
1	p	x	OOSB	For access violation fault - out of segment bounds
1	q	x	PARU	For parity fault - processor parity upper
1	r	x	PARL	For parity fault - processor parity lower
1	s	x	ONC1	For operation not complete fault - processor/system controller sequence error #1
1	t	x	ONC2	For operation not complete fault - processor/system controller sequence error #2
1			x IA	System controller illegal action lines (see Table 3-1)
1			x IACHN	Illegal action processor port
1			x CNCHN	For connect fault - connect processor port
1			x F/I ADDR	Modulo 2 fault/interrupt vector address
1	u	x	F/I	Fault/interrupt flag
				0 = interrupt
				1 = fault

<u>Word</u>	<u>key</u>	<u>L</u>	<u>Field name</u>	<u>Meaning</u>
2			TRR	Temporary ring register (TPR.TRR)
2			TSR	Temporary segment register (TPR.TSR)
			PTW	DPS 8M processors only; this field mbz on DPS/L68 processors:
2	a	x		PTWAM levels A, B enabled (enabled = 1)
2	b	x		PTWAM levels C, D enabled
2	c	x		PTWAM levels A, B match (match = 1)
2	d	c		PTWAM levels C, D match
			SDW	DPS 8M processors only; this field mbz on DPS/L68 processors:
2	e	x		SDWAM levels A, B enabled
2	f	x		SDWAM levels C, D enabled
2	g	x		SDWAM levels A, B match
2	h	x		SDWAM levels C, D match
2			CPU	CPU number
2			DELTA	Address increment for repeats
3			TSNA	Pointer register number for non-EIS operands or for EIS operand #1 further substructured as:
3	a		PRNO	Pointer register number
3	b	----		1 = PRNO is valid
3			TSNB	Pointer register number for EIS operand #2 further substructured as for TSNA above
3			TSNC	Pointer register number for EIS operand #3 further substructured as for TSNA above
3			TEMP BIT	Current bit offset (TPR.TBR)
4			IC	Instruction counter (PPR.IC)
4	a		ZERO	Zero indicator
4	b		NEG	Negative indicator
4	c		CARY	Carry indicator
4	d		OVFL	Overflow indicator
4	e		EOVF	Exponent overflow indicator
4	f		EUFL	Exponent underflow indicator
4	g		OFLM	Overflow mask indicator
4	h		TRO	Tally runout indicator
4	i		PAR	Parity error indicator
4	j		PARM	Parity mask indicator
4	k		$\overline{\text{BM}}$	Not BAR mode indicator
4	l		TRU	EIS truncation indicator
4	m		MIF	Mid-instruction interrupt indicator

<u>Word</u>	<u>key</u>	<u>L</u>	<u>Field name</u>	<u>Meaning</u>
4	n		ABS	Absolute mode indicator
4	o		HEX	Hex mode indicator (DPS 8M processors only)
5	x		CA	Current computed address (TPR.CA)
5	a		RF	First cycle of all repeat instructions
5	b		RPT	Execute a Repeat (rpt) instruction
5	c		RD	Execute a Repeat Double (rpd) instruction
5	d		RL	Execute a Repeat Link (rpl) instruction
5	e		POT	Prepare operand tally. This flag is up until the indirect word of an indirect then tally address modifier is successfully fetched.
5	f		PON	Prepare operand no tally. This flag is up until the indirect word of a return type transfer instruction is successfully fetched. It indicates that there is no indirect chain even though an indirect fetch is being performed.
5	g		XDE	Execute instruction from Execute Double even pair
5	h		XDO	Execute instruction from Execute Double odd pair
5	i		ITP	Execute ITP indirect cycle
5	j		RFI	Restart this instruction
5	k		ITS	Execute ITS indirect cycle
5	l		FIF	Fault occurred during instruction fetch
5			CT HOLD	Contents of the modifier holding register
6				Word 6 is the contents of the working instruction register and reflects conditions at the exact point of address preparation when the fault or interrupt occurred. The ADDRESS and TAG fields are replaced with data from pointer registers, indirect pointers, and/or indirect words during each indirect cycle. Each instruction of the current pair is moved to this register before actual address preparation begins.
7				Word 7 is the contents of the instruction holding register. It contains the odd word of the last instruction pair fetched from main memory. Note that, primarily because of overlap, this instruction is not necessarily paired with the instruction in word 6.

DECIMAL UNIT DATA

Format: - 288 bits, 8 machine words

Data as stored by Store Pointers and Lengths (spl) instruction.

Word

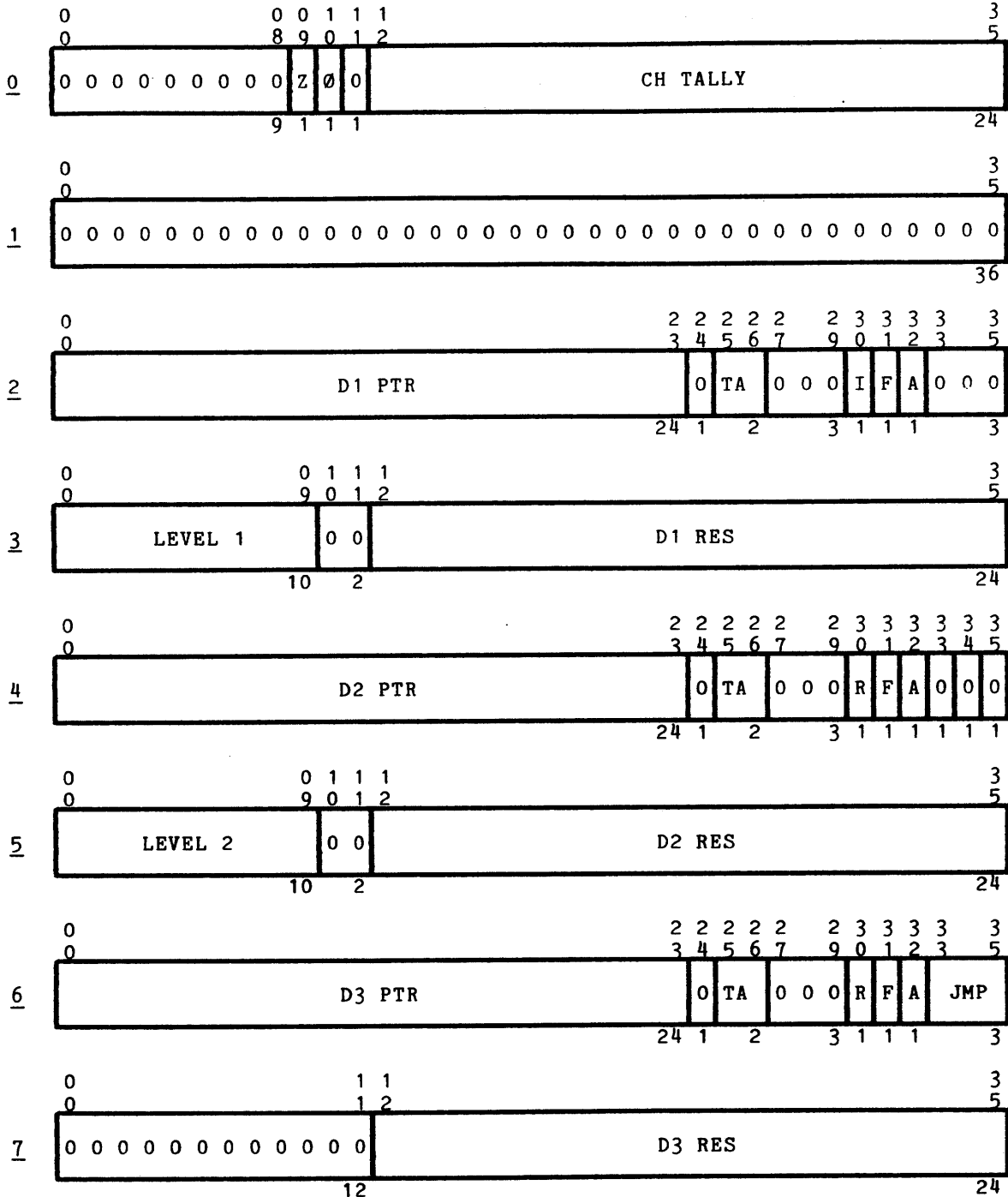

Figure 3-33. Decimal Unit Data Format

Description:

A collection of flags and registers from the decimal unit.

Function:

The decimal unit data allows the processor to restart an EIS instruction at the point of interruption when it is interrupted by an access violation fault, a directed fault, or (for certain EIS instructions) an interrupt. Directed faults are intentional, and most access violation faults and interrupts are recoverable.

The data are restored with the Load Pointers and Lengths (lpl) instruction. Fields having an "x" in the column headed L are not restored. When starting (or restarting) execution of an EIS instruction, the decimal unit registers and flags are not initialized from the operand descriptors if the mid-instruction interrupt fault (MIF) indicator is set ON.

The meanings of the constituent flags and registers are:

<u>Word</u>	<u>L</u>	<u>Field name</u>	<u>Meaning</u>
0		Z	All bit-string instruction results are zero
0		Ø	Negative overpunch found in 6-4 expanded move
0		CHTALLY	The number of characters examined by the scm, scmr, scd, scdr, tct, or tctr instructions (up to the interrupt or match)
2		D1 PTR	Address of the last double-word accessed by operand descriptor 1; bits 17-23 (bit-address) valid only for initial access
2,4,6		TA	Alphanumeric type of operand descriptor 1,2,3
2	x	I	Decimal unit interrupted flag; a copy of the mid-instruction interrupt fault indicator
2,4,6		F	First time; data in operand descriptor 1,2,3 is valid
2,4,6		A	Operand descriptor 1,2,3 is active
3		LEVEL 1	Difference in the count of characters loaded into the processor and characters not acted upon
3		D1 RES	Count of characters remaining in operand descriptor 1
4		D2 PTR	Address of the last double-word accessed by operand descriptor 2; bits 17-23 (bit-address) valid only for initial access
4,6	x	R	Last cycle performed must be repeated
5		LEVEL 2	Same as LEVEL 1, but used mainly for OP 2 information
5		D2 RES	Count of characters remaining in operand descriptor 2
6		D3 PTR	Address of the last double-word accessed by operand descriptor 3; bits 17-23 (bit-address) valid only for initial access

<u>Word</u>	<u>L</u>	<u>Field</u> <u>name</u>	<u>Meaning</u>
6		JMP	Descriptor count; number of words to skip to find the next instruction following this multiword instruction
7		D3 RES	Count of characters remaining in operand descriptor 3

SECTION 4

MACHINE INSTRUCTIONS

This section describes the complete set of machine instructions for the Multics processor. The presentation assumes that the reader is familiar with the general structure of the processor, the representation of information, the data formats, and the method of address preparation. Additional information on these subjects appears near the beginning of this section and in Sections 2, 3, 5, and 6.

INSTRUCTION REPERTOIRE

The processor interprets a 10-bit field of the instruction word as the operation code. This field size yields 1024 possible instructions of which 547 are implemented. There are 456 basic operations and 91 extended instruction set (EIS) operations.

Arrangement of Instructions

Instructions are presented alphabetically by their mnemonic codes within functional categories. An overall alphabetic listing of instruction codes and their names appears in Appendix B.

Basic Operations

The 456 basic operations in the processor all require exactly one 36-bit machine word. They are categorized as follows:

181	Fixed-point binary arithmetic
85	Boolean operations
34	Floating-point binary arithmetic
36	Transfer of control
75	Pointer register
17	Miscellaneous
28	Privileged

Extended Instruction Set (eis) Operations

The 91 extended instruction set (EIS) operations are divided into 62 EIS single-word instructions and 29 EIS multiword instructions.

EIS SINGLE-WORD OPERATIONS

The 62 EIS single-word instructions load, store, and perform special arithmetic on the address registers (ARn) used to access bit- and character-string operands, and safe-store decimal unit (DU) control information required to service a processor fault or interrupt. Like the basic operations, EIS single-word instructions require exactly one 36-bit machine word.

EIS MULTIWORD OPERATIONS

The 29 EIS multiword instructions perform decimal arithmetic and bit- and character-string operations. They require three or four 36-bit machine words depending on individual operand descriptor requirements.

FORMAT OF INSTRUCTION DESCRIPTION

Each instruction in the repertoire is described in the following pages of this section. The descriptions are presented in the format shown below.

MNEMONIC	INSTRUCTION NAME	OPCODE
----------	------------------	--------

FORMAT: Figure or figure reference

SUMMARY: Text and/or bit transfer equations

MODIFICATIONS: Text

INDICATORS: Text and/or logic statements

NOTES: Text

Line 1: MNEMONIC, INSTRUCTION NAME, OPCODE

This line has three parts that contain the following:

1. MNEMONIC -- The mnemonic code for the operation field of the assembler statement. The Multics assembler, ALM, recognizes this character string value and maps it into the appropriate binary pattern when generating the actual object code.
2. INSTRUCTION NAME -- The name of the machine instruction from which the mnemonic was derived.
3. OPCODE -- The octal value of the operation code for the instruction. A 0 or a 1 in parentheses following an octal code indicates whether bit 27 (opcode extension bit) of the instruction word is OFF or ON.

Line 2: FORMAT

The layout and definition of the subfields of the instruction word or words are given here either as a figure or as a reference to a figure.

Line 3: SUMMARY

The change in the state of the processor effected by the execution of the instruction is described in a short, symbolic form. If reference is made to the state of an indicator in the summary, it is the state of the indicator before the instruction is executed.

Line 4: MODIFICATIONS

Those modifiers that cannot be used with the instruction are listed explicitly as exceptions. See Section 6 for a discussion of address modification.

Line 5: INDICATORS

Only those indicators are listed whose state can be changed by the execution of the instruction. In most cases, a condition for setting ON as well as one for setting OFF is stated. If only one of the two is stated, then the indicator remains unchanged if the condition is not met. Unless stated otherwise, the conditions refer to the contents of registers existing after instruction execution. Refer also to "Common Attributes of Instructions," later in this section.

Line 6: NOTES

This part of the description exists only in those cases where the summary is not sufficient for in-depth understanding of the instruction.

DEFINITIONS OF NOTATION AND SYMBOLS

Main Memory Addresses

- y = an 18-bit computed address as generated during address preparation.
- Y = a 24-bit main memory address of the instruction operand after all address preparation (including appending) is complete.
- Y-pair = a pair of main memory locations with successive addresses, the smaller address being even. When Y is even, it designates the pair Y(even), Y+1; and when it is odd, the pair Y-1, Y(odd). The main memory location with the smaller (even) address contains the most significant part of a double-word operand or the first of a pair of instructions.
- Y-block_n = a block of main memory locations of 4-, 8-, 16-, or 32-word extent. For a block of n-word extent, the processor forces Y-block_n to a 0 modulo n address and performs address incrementing through the block accordingly, stopping when the address next reaches a value 0 modulo n.
- Y-char_nk = a character or string of characters in main memory of character size n bits as described by the kth operand descriptor. n is specified by the data type field of operand descriptor k and may have values 4, 6, or 9. See Section 6 for details of operand descriptors.
- Y-bit_k = a bit or string of bits in main memory as described by the kth operand descriptor. See Section 6 for details of operand descriptors.

Index Values

When reference is made to the elements of a string of characters or bits in main memory, the notation shown in "Register Position and Contents" below is used. The index used to show traversing a string of extent n may take any of the values in the interval (1,n) unless noted otherwise. The elements of a main memory block are traversed explicitly by using the index as an addend to the given block address, (e.g., Y-block8+m and Y-block4+2m+1).

Abbreviations and Symbols

A	Accumulator register
AR _n	Address register <u>n</u> (<u>n</u> = 0, 1, 2, ..., 7)
AQ	Combined accumulator-quotient register
BAR	Base address register
C()	"Contents of"
CA	Computed address
DSBR	Descriptor segment base register
DSBR.ADDR	Address field of DSBR
DSBR.BND	Bound field of DSBR
DSBR.STACK	Stack base field of DSBR
DSBR.U	Unpaged flag of DSBR

E	Exponent register
EA	Combined exponent-accumulator register
EAQ	Combined exponent-accumulator-quotient register
ERN	Effective ring number
ESN	Effective segment number
IC	Instruction counter
IR	Indicator register
PPR	Procedure pointer register
PPR.PRR	Procedure ring register of PPR
PPR.PSR	Procedure segment register of PPR
PPR.IC	Instruction counter register of PPR (same as IC above)
PPR.P	Privileged flag of PPR
PRn	Pointer register n (n = 0, 1, 2, ..., 7)
PRn.RNR	Ring number register of PRn
PRn.SNR	Segment number register of PRn
PRn.WORDNO	Word address register of PRn
PRn.CHAR	Character address register of PRn
PRn.BITNO	Bit offset register of PRn
Q	Quotient register
PTWAM	Page table word associative memory
SDWAM	Segment descriptor word associative memory
RALR	Ring alarm register
TPR	Temporary pointer register
TPR.CA	Computed address register of TPR (same as CA above)
TPR.TRR	Temporary ring register of TPR
TPR.TSR	Temporary segment register of TPR
TPR.TBR	Temporary bit register of TPR
TR	Timer register
Xn	Index register n (n = 0, 1, 2, ..., 7)
Z	Temporary pseudo-result of a nonstore comparative operation

Register Positions and Contents

In the definitions that follow, "R" stands for any of the registers listed above, as well as for main memory words, word-pairs, word-blocks, and bit- or character-strings.

R_i	The i^{th} bit, character, or byte position of R	
$R(i)$	The i^{th} register of a set of n registers named R	
$R_{i,j}$	The bit, character, or byte positions i through j of R	
$C(R)$	The contents of the full register R	
$C(R)_i$	The contents of the i^{th} bit, character, or byte of R	
$C(R)_{i,j}$	The contents of the bits, characters, or bytes i through j of R	
xx...x	A string of binary bits (0's or 1's) of any necessary length	

When the description of an instruction specifies a change for a part of a register or main memory location, it is understood that the part of the register or main memory location not mentioned remains unchanged.

Other Symbols

->	replaces
::	compare with

&	the Boolean connective AND
	the Boolean connective OR
⊕	the Boolean connective NON-EQUIVALENCE (or EXCLUSIVE OR)
\overline{XXX}	the logical inverse (ones complement) of the quantity XXX
≠	not equal
n**m	indicates exponentiation (n and m are integers); for example, the fifth power of 2 is represented as 2**5.
X	multiplication; for example, C(Y) times C(Q) is represented as C(Y) X C(Q).
/	division; for example, C(Y) divided by C(A) is represented as C(Y) / C(A).
	concatenation; for example, string1 string2.
...	the absolute value of the value between vertical bars (no algebraic sign). For example the absolute value of C(A) plus C(Y) is represented as: $ C(A) + C(Y) $.
C(R) mod n	A coined notation for remaindering or modulo arithmetic; for example C(REG) modulo 9 is represented as C(REG) mod 9.

COMMON ATTRIBUTES OF INSTRUCTIONS

Illegal Modification

If an illegal modifier is used with any instruction, an illegal procedure fault with a subcode class of illegal modifier occurs.

Parity Indicator

The parity indicator is turned ON at the end of a main memory access that has incorrect parity.

INSTRUCTION WORD FORMATS

Basic and EIS Single-Word Instructions

The basic instructions and EIS single-word instructions require exactly one 36-bit machine word and are interpreted according to the format shown in Figure 4-1.

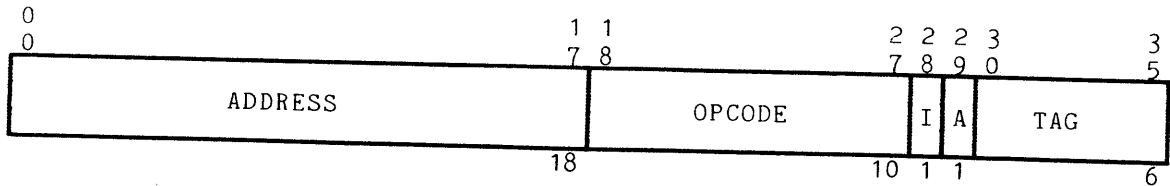

Figure 4-1. Basic and EIS Single-Word Instruction Format

- ADDRESS** The given address of the operand or indirect word. This address may be:
- An 18-bit absolute main memory address if A = 0 (absolute mode only)
 - An 18-bit offset relative to the base address register if A = 0 (BAR mode only)
 - An 18-bit offset relative to the base of the current procedure segment if A = 0 (appending mode only)
 - A 3-bit pointer register number (n) and a 15-bit offset relative to C(PRn.WORDNO) if A = 1 (absolute and appending modes only)
 - A 3-bit address register number (n) and a 15-bit offset relative to C(ARn) if A = 1 (all modes depending on instruction type)
 - An 18-bit literal signed or unsigned constant (all modes depending on instruction type and modifier)
 - An 8-bit shift operation count (all modes)
 - An 18-bit offset relative to the current value of the instruction counter C(PPR.IC) (all modes)
- OPCODE** Instruction operation code.
- I** Interrupt inhibit bit. When this bit is set ON, the processor will defer all external interrupt signals. See Section 7 for a discussion of interrupts.
- A** Indirect via pointer register flag. See Section 6 for a discussion of the use of pointer registers.
- TAG** Instruction address modifier. See Section 6 for a discussion of address modification.

Machine words in this format are generated by ALM in processing the basic and EIS single-word instructions (described later in this section) and the arg pseudo-instruction).

Indirect Words

Certain of the basic and EIS single-word instructions permit indirection to be specified as part of address modification. When such indirection is

specified, C(Y) is interpreted as an indirect word according to the format shown in Figure 4-2.

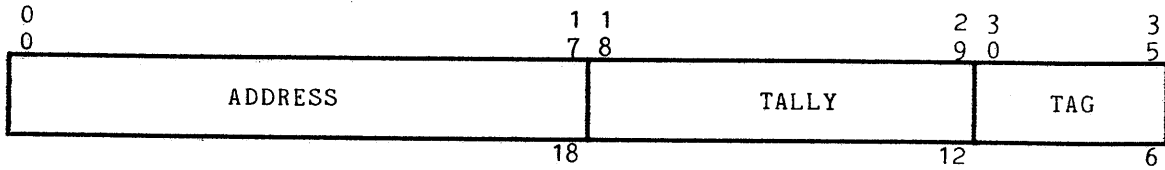

Figure 4-2. Indirect Word Format

ADDRESS The given address of the operand or next indirect word. This address may be:

An 18-bit absolute main memory address if A = 0 in the instruction word (absolute mode only)

An 18-bit offset relative to the base address register (BAR) if A = 0 in the instruction word (BAR mode only)

An 18-bit offset relative to the base of the segment in which the word resides if A = 0 (appending mode only)

Three zero bits and a 15-bit segment number if TAG = (43)₈ (its modification) (absolute and appending modes only)

A 3-bit pointer register number and 15 zero bits if TAG = (41)₈ (its modification) (absolute and appending modes only)

TALLY A count field for use by those address modifiers that involve tallying

TAG This field may be (depending on the TAG value causing the indirection);

A 6-bit address modifier

A 6-bit increment to be added to or subtracted from ADDRESS on each reference

A 1-bit character mode (6- or 9-bit) flag, two 0 bits, and a 3-bit character position number

Machine words in this format may be generated by use of the ALM vfd pseudo-instruction.

EIS Multiword Instructions

The EIS multiword instructions require three or four machine words depending on the operand descriptor requirements of the individual instructions. The words are interpreted according to the format shown in Figure 4-3. The instruction descriptions (later in this section) contain ALM coding examples. Refer to the MPM Subsystem Writers' Guide, Order No. AK92, "alm Command" for additional information.

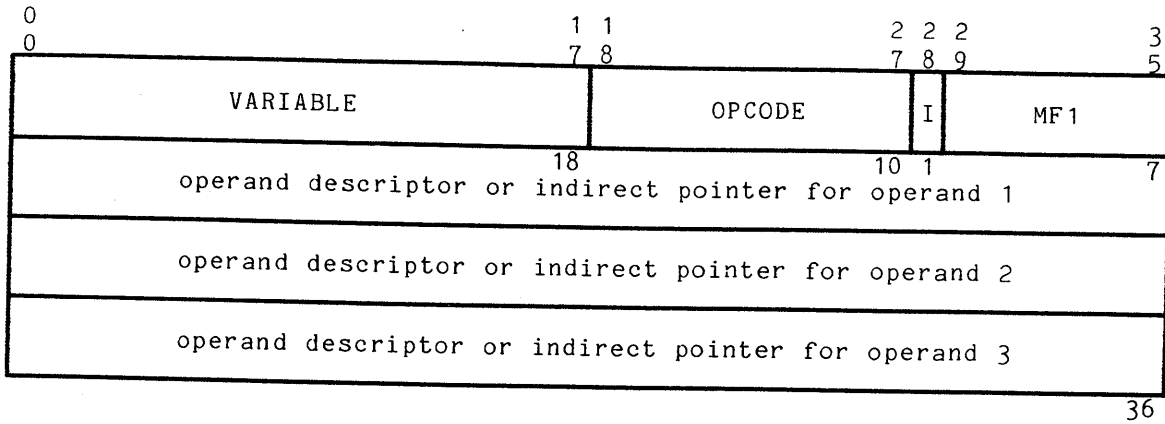

Figure 4-3. EIS Multiword Instruction Format

- VARIABLE
 This field is interpreted variously according to the requirements of the individual EIS instructions. Its interpretation is given under FORMAT for each EIS instruction. The modification fields MF2 and MF3 are contained in this field if they are required.
- OPCODE
 Instruction operation code as for basic and EIS single-word instructions.
- I
 Interrupt inhibit bit as for basic and EIS single-word instructions.
- MF1
 Modification field for operand descriptor 1. See EIS modification fields (MF) below for details.

Machine words in this format are generated by ALM in processing the EIS multiword instructions described later in this section and their associated operand descriptor or indirect pointer pseudo-operations.

EIS Modification Fields (MF)

Each of the operand descriptors following an EIS multiword instruction word has a modification field in the instruction word. The modification field controls the interpretation of the operand descriptor. The modification field is interpreted according to the format shown in Figure 4-4.

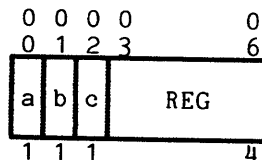

Figure 4-4. EIS Modification Field (MF) Format

key
a AR

Address register flag. This flag controls interpretation of the ADDRESS field of the operand descriptor just as the

"A" flag controls interpretation of the ADDRESS field of the basic and EIS single-word instructions. The ALM coding mnemonic for this flag is "pr".

- b RL Register length control. If RL = 0, then the length (N) field of the operand descriptor contains the length of the operand. If RL = 1, then the length (N) field of the operand descriptor contains a selector value specifying a register holding the operand length. Operand length is interpreted as units of the data size (1-, 4-, 6-, or 9-bit) given in the associated operand descriptor. The ALM coding mnemonic for this flag is "rl".
- c ID Indirect descriptor control. If ID = 1 for MF_k, then the kth word following the instruction word is an indirect pointer to the operand descriptor for the kth operand; otherwise, that word is the operand descriptor. The ALM coding mnemonic for this flag is "id".
- REG The register number for R-type modification (if any) of ADDRESS of the operand descriptor. These modifications are similar to R-type modifications for basic instructions and are summarized in Table 4-1. Illegal modifiers have the entry "IPR" and cause an illegal procedure fault.

Table 4-1. R-type Modifiers for REG Fields

Octal Code	R-type	Meaning as used in:		
		MF.REG	Indirect operand descriptor-pointer	C(operand descriptor) _{32,35}
00	n	n	n	IPR
01	au	au	au	au
02	qu	qu	qu	qu
03	du	IPR	IPR	du(a)
04	ic	ic	ic	ic(b)
05	al	a(c)	al	a(c)
06	ql	q(c)	ql	q(c)
07	d1	IPR	IPR	IPR
10	x0	x0	x0	x0
11	x1	x1	x1	x1
12	x2	x2	x2	x2
13	x3	x3	x3	x3
14	x4	x4	x4	x4
15	x5	x5	x5	x5
16	x6	x6	x6	x6
17	x7	x7	x7	x7

- (a) The du modifier is permitted only in the second operand descriptor of the scd, scdr, scm, and scmr instructions to specify that the test character(s) reside(s) in bits 0-18 of the operand descriptor.
- (b) The ic modifier is permitted in MF_k.REG and C(od)_{32,35} only if MF_k.RL = 0, that is, if the contents of the register is an address offset, not the designation of a register containing the operand length.

- c) The limit of addressing extent of the processor is 2^{18} words; that is, given an address, y , a modifier may be employed to access a main memory word anywhere in the range $(y-2^{17}, y+2^{17}-1)$, provided other address range constraints are not violated. Since it is desirable to address this same extent as words, characters, and bits it is necessary to provide a register with range greater than the 12 bits of N or the 18 bits of normal R-type modifiers. This is done by extending the range of the A and Q modifiers as follows:

<u>Mode</u>	<u>Range</u>	<u>A,Q bits</u>
9-bit	21	15,35
6-bit	21	15,35
4-bit	22	14,35
bit	24	12,35

The unused high-order bits are ignored.

MF CODING EXAMPLES

All of the EIS instruction descriptions in this section give examples of ALM coding formats. For example, the mlr instruction shows:

```
mlr      (MF1),(MF2)[,fill(octalexpression)][,enablefault]
descna  Y-charn1[(CN1)],N1      n = 4, 6, or 9 (TA1 = 2, 1, or 0)
descna  Y-charn2[(CN2)],N2      n = 4, 6, or 9 (TA2 = 2, 1, or 0)
```

where MF1 and MF2 represent the EIS Modifier Fields for the first and second data descriptors, respectively.

The meanings of the various codes in an MF field are:

<u>If C(MFn)</u> <u>Contains</u>	<u>It Means</u>
pr	Y-char _n is not the memory address of the data but is a reference to a pointer register pointing to the data.
id	The data in desc _n is not the data descriptor but is the memory address (or pointer register reference) of the data descriptor.
rl	The field <u>N_n</u> is not the data length but is the code for register containing the data length (see Table 4-1).

EIS Operand Descriptors and Indirect Pointers

The words following an EIS multiword instruction word are either operand descriptors or indirect pointers to the operand descriptors. The interpretation of the words is performed according to the settings of the control bits in the associated modification field (MF). The k th word following the instruction word is interpreted according to the contents of MF_k. See EIS modification fields (MF) above for meaning of the various control bits. See Section 2 and Section 6 for further details.

OPERAND DESCRIPTOR INDIRECT POINTER FORMAT

If MFk.ID = 1, then the kth word following an EIS multiword instruction word is not an operand descriptor, but is an indirect pointer to an operand descriptor and is interpreted as shown in Figure 4-5.

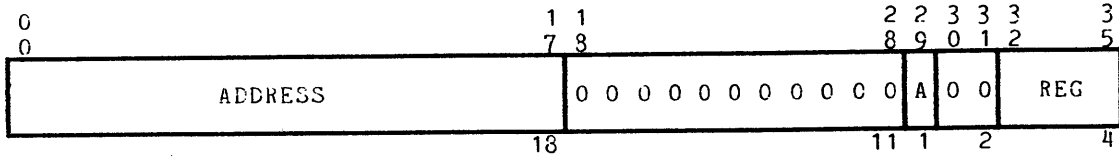

Figure 4-5. Operand Descriptor Indirect Pointer Format

- ADDRESS** The given address of the operand descriptor. This address may be:
- An 18-bit absolute main memory address if A = 0 (absolute mode only)
 - An 18-bit offset relative to the base address register (BAR) if A = 0 (BAR mode only)
 - An 18-bit offset relative to the base of the current procedure segment if A = 0 (appending mode only)
 - A 3-bit pointer register number (n) and a 15-bit offset relative to C(PRn.WORDNO) if A = 1 (all modes)
- A** Indirect via pointer register flag. This flag controls interpretation of the ADDRESS field of the indirect pointer just as the "A" flag controls interpretation of

the ADDRESS field of the basic and EIS single-word instructions.

REG Address modifier for ADDRESS. All register modifiers except du and dl may be used. If the ic modifier is used, then ADDRESS is an 18-bit offset relative to value of the instruction counter for the instruction word. C(REG) is always interpreted as a word offset.

Machine words in this format are generated by the ALM arg pseudo-instruction giving an appropriate TAG field.

ALPHANUMERIC OPERAND DESCRIPTOR FORMAT

For any operand of an EIS multiword instruction that requires alphanumeric data, the operand descriptor is interpreted as shown in Figure 4-6.

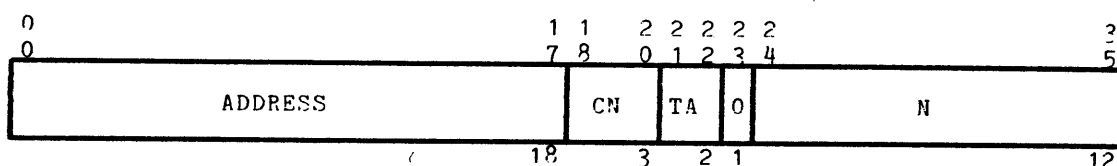

Figure 4-6. Alphanumeric Operand Descriptor Format

ADDRESS The given address of the operand. This address may be (for the kth operand):

An 18-bit absolute main memory address if MF_k.AR = 0 (absolute mode only)

An 18-bit offset relative to the base address register if MF_k.AR = 0 (BAR mode only)

An 18-bit offset relative to the base of the current procedure segment if MF_k.AR = 0 (appending mode only)

A 3-bit address register number (n) and a 15-bit word offset relative to C(AR_n) if MF_k.AR = 1 (all modes)

CN Character number. This field gives the character position relative to ADDRESS of the first operand character. Its interpretation depends on the data type (see TA below) of the operand. Table 4-2 below shows the interpretation of the field. A digit in the table indicates the corresponding character position (see Section 2 for data formats) and an "x" indicates an invalid code for the data type. Invalid codes cause illegal procedure faults. (For further explanation, see the Note under AR_n.BITNO. in Section 3, "Address Registers".)

Table 4-2. Alphanumeric Character Number (CN) Codes

C(CN)	Data type		
	4-bit	6-bit	9-bit
000	0	0	0
001	1	1	x
010	2	2	1
011	3	3	x
100	4	4	2
101	5	5	x
110	6	x	3
111	7	x	x

TA

Type alphanumeric. This is the data type code for the operand. The interpretation of the field is shown in Table 4-3. The code shown as Invalid causes an illegal procedure fault.

Table 4-3. Alphanumeric Data Type (TA) Codes

C(TA)	Data type
00	9-bit
01	6-bit
10	4-bit
11	Invalid

N

Operand length. If MFk.RL = 0, this field contains the string length of the operand. If MFk.RL = 1, this field contains the code for a register holding the operand string length. See Table 4-1 and EIS modification fields (MF) above for a discussion of register codes.

Machine words of this format are generated by ALM when processing the desc4a, desc6a, and desc9a pseudo-instructions.

NUMERIC OPERAND DESCRIPTOR FORMAT

For any operand of an EIS multiword instruction that requires numeric data, the operand descriptor is interpreted as shown in Figure 4-7.

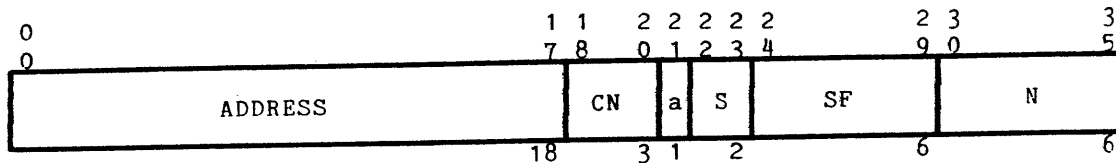

Figure 4-7. Numeric Operand Descriptor Format

key

ADDRESS

The given address of the operand. This address may be (for the kth operand):

An 18-bit absolute main memory address if MFk.AR= 0 (absolute mode only)

An 18-bit offset relative to the base address register if MFk.AR = 0 (BAR mode only)

An 18-bit offset relative to the base of the current procedure segment if MFk.AR = 0 (appending mode only)

A 3-bit address register number (n) and a 15-bit word offset relative to C(ARn) if MFk.AR = 1 (all modes)

CN

Character number. This field gives the character position relative to ADDRESS of the first operand digit. Its interpretation depends on the data type (see TN below) of the operand. Table 4-2 above shows the interpretation of the field. (For further information, see the Note under ARn.BITNO in Section 3 on Address Registers.)

a TN

Type numeric. This is the data type code for the operand. The codes are:

<u>C(TN)</u>	<u>Data type</u>
0	9-bit
1	4-bit

S

Sign and decimal type of data. The interpretation of the field is shown in Table 4-4.

Table 4-4. Sign and Decimal Type (S) Codes

<u>C(S)</u>	<u>Sign and decimal type</u>
00	Floating-point, leading sign
01	Scaled fixed-point, leading sign
10	Scaled fixed-point, trailing sign
11	Scaled fixed-point, unsigned

SF

Scaling factor. This field contains the two's complement value of the base 10 scaling factor; that is, the value of m for numbers represented as n x 10**m. The decimal point is assumed to the right of the least significant digit of n. Negative values move the decimal point to the left; positive values, to the right. The range of m is (-32,31).

N Operand length. If $MF_k.RL = 0$, this field contains the operand length in digits. If $MF_k.RL = 1$, it contains the REG code for the register holding the operand length and $C(REG)$ is treated as a 0 modulo 64 number. See Table 4-1 and EIS modification fields (MF) above for a discussion of register codes.

Machine words in this format are generated by ALM when processing the desc4f1, desc4ls, desc4ts, desc4ns, desc9f1, desc9ls, desc9ts, and desc9ns pseudo-instructions.

BIT-STRING OPERAND DESCRIPTOR FORMAT

For any operand of an EIS multiword instruction that requires bit-string data, the operand descriptor is interpreted as shown in Figure 4-8.

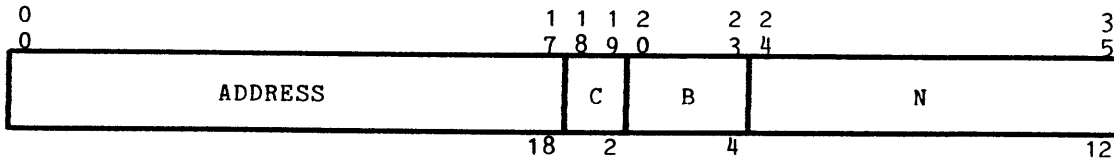

Figure 4-8. Bit String Operand Descriptor Format

- ADDRESS** The given address of the operand. This address may be (for the k th operand):
- An 18-bit main memory address if $MF_k.AR = 0$ (absolute mode only)
 - An 18-bit offset relative to the base address register if $MF_k.AR = 0$ (BAR mode only)
 - An 18-bit offset relative to the base of the current procedure segment if $MF_k.AR = 0$ (appending mode only)
 - A 3-bit address register number (n) and a 15-bit word offset relative to $C(AR_n)$ if $MF_k.AR = 1$ (all modes)
- C** The character number of the 9-bit character relative to ADDRESS containing the first bit of the operand. (For further explanation, see the Note under AR_n BITNO in Section 3 on Address Registers.)
- B** The bit number within the 9-bit character, C, of the first bit of the operand.
- N** Operand length. If $MF_k.RL = 0$, this field contains the string length of the operand. If $MF_k.RL = 1$, this field contains the code for a register holding the operand string length. See Table 4-1 and EIS modification fields (MF) above for a discussion of register codes.

Machine words of this format are generated by ALM when processing the descb pseudo-instruction.

FIXED-POINT DATA MOVEMENT LOAD

FIXED-POINT ARITHMETIC INSTRUCTIONS

Fixed-Point Data Movement Load

aaa	Effective Address to A	635 (0)
-----	------------------------	---------

FORMAT: Basic instruction format (see Figure 4-1).

SUMMARY C(TPR.CA) → C(A)_{0,17}
00...0 → C(A)_{18,35}

MODIFICATIONS: All except du, dl

INDICATORS: (Indicators not listed are not affected)

Zero If C(A) = 0, then ON; otherwise OFF

Negative If C(A)₀ = 1, then ON; otherwise OFF

NOTES: The aaa instruction, and the instructions eaq and ean, facilitate interregister data movements. The data source is specified by the address modification, and the data destination by the operation code of the instruction.

Attempted repetition with the rpl instruction causes an illegal procedure fault.

eaq	Effective Address to Q	636 (0)
-----	------------------------	---------

FORMAT: Basic instruction format (see Figure 4-1).

SUMMARY C(TPR.CA) → C(Q)_{0,17}
00...0 → C(Q)_{18,35}

MODIFICATIONS: All except du, dl

INDICATORS: (Indicators not listed are not affected)

Zero If $C(Q) = 0$, then ON; otherwise OFF

Negative If $C(Q)_0 = 1$, then ON; otherwise OFF

NOTES: Attempted repetition with the rpl instruction causes an illegal procedure fault.

eax _n	Effective Address to Index Register <u>n</u>	62 _n (0)
------------------	--	---------------------

FORMAT: Basic instruction format (see Figure 4-1).

SUMMARY: For $n = 0, 1, \dots, \text{or } 7$ as determined by operation code
 $C(\text{TPR.CA}) \rightarrow C(X_n)$

MODIFICATIONS: All except du, dl

INDICATORS: (Indicators not listed are not affected)

Zero If $C(X_n) = 0$, then ON; otherwise OFF

Negative If $C(X_n)_0 = 1$, then ON; otherwise OFF

NOTES: Attempted repetition with the rpl instruction causes an illegal procedure fault.

lca	Load Complement A	335 (0)
-----	-------------------	---------

FORMAT: Basic instruction format (see Figure 4-1).

SUMMARY: $-C(Y) \rightarrow C(A)$

MODIFICATIONS: All

FIXED-POINT DATA MOVEMENT LOAD

INDICATORS: (Indicators not listed are not affected)

Zero If $C(A) = 0$, then ON; otherwise OFF

Negative If $C(A)_0 = 1$, then ON; otherwise OFF

Overflow If range of A is exceeded, then ON

NOTES: The lca instruction changes the number to its negative while moving it from Y to A. The operation is executed by forming the twos complement of the string of 36 bits. In twos complement arithmetic, the value 0 is its own negative. An overflow condition exists if $C(Y) = -2^{**35}$.

lcaq	Load Complement AQ	337 (0)
------	--------------------	---------

FORMAT: Basic instruction format (see Figure 4-1).

SUMMARY: $-C(Y\text{-pair}) \rightarrow C(AQ)$

MODIFICATIONS: All except du, dl, ci, sc, scr

INDICATORS: (Indicators not listed are not affected)

Zero If $C(AQ) = 0$, then ON; otherwise OFF

Negative If $C(AQ)_0 = 1$, then ON; otherwise OFF

Overflow If range of AQ is exceeded, then ON

NOTES: The lcaq instruction changes the number to its negative while moving it from Y-pair to AQ. The operation is executed by forming the twos complement of the string of 72 bits. In twos complement arithmetic, the value 0 is its own negative. An overflow condition exists if $C(Y\text{-pair}) = -2^{**71}$.

lcq	Load Complement Q	336 (0)
-----	-------------------	---------

FORMAT: Basic instruction format (see Figure 4-1).

SUMMARY: $-C(Y) \rightarrow C(Q)$

MODIFICATIONS: All

INDICATORS: (Indicators not listed are not affected)

Zero If $C(Q) = 0$, then ON; otherwise OFF
 Negative If $C(Q)_0 = 1$, then ON; otherwise OFF
 Overflow If range of Q is exceeded, then ON

NOTES: The `lcq` instruction changes the number to its negative while moving it from Y to Q. The operation is executed by forming the twos complement of the string of 36 bits. In twos complement arithmetic, the value 0 is its own negative. An overflow condition exists if $C(Y) = -2^{**35}$.

<code>lcxn</code>	Load Complement Index Register <u>n</u>	32 <u>n</u> (0)
-------------------	---	-----------------

FORMAT: Basic instruction format (see Figure 4-1).

SUMMARY: For $n = 0, 1, \dots, \text{or } 7$ as determined by operation code
 $-C(Y)_{0,17} \rightarrow C(Xn)$

MODIFICATIONS: All except `ci`, `sc`, `scr`

INDICATORS: (Indicators not listed are not affected)

Zero If $C(Xn) = 0$, then ON; otherwise OFF
 Negative If $C(Xn)_0 = 1$, then ON; otherwise OFF
 Overflow If range of Xn is exceeded, then ON

NOTES: The `lcxn` instruction changes the number to its negative while moving it from $Y_{0,17}$ to Xn . The operation is executed by forming the twos complement of the string of 18 bits. In twos complement arithmetic, the value 0 is its own negative. An overflow condition exists if $C(Y)_{0,17} = -2^{**17}$.

Attempted repetition with the `rpl` instruction and with the same register given as target and modifier causes an illegal procedure fault.

<code>lda</code>	Load A	235 (0)
------------------	--------	---------

FORMAT: Basic instruction format (see Figure 4-1).

FIXED-POINT DATA MOVEMENT LOAD

SUMMARY: C(Y) -> C(A)

MODIFICATIONS: All

INDICATORS: (Indicators not listed are not affected)

Zero If C(A) = 0, then ON; otherwise OFF

Negative If C(A)₀ = 1, then ON; otherwise OFF

ldac	Load A and Clear	034 (0)
------	------------------	---------

FORMAT: Basic instruction format (see Figure 4-1).

SUMMARY: C(Y) -> C(A)
00...0 -> C(Y)

MODIFICATIONS: All except du, dl, ci, sc, scr

INDICATORS: (Indicators not listed are not affected)

Zero If C(A) = 0, then ON; otherwise OFF

Negative If C(A)₀ = 1, then ON, otherwise OFF

NOTES: The ldac instruction causes a special main memory reference that performs the load and clear in one cycle. Thus, this instruction can be used in locking data.

ldaq	Load AQ	237 (0)
------	---------	---------

FORMAT: Basic instruction format (see Figure 4-1).

SUMMARY: C(Y-pair) -> C(AQ)

MODIFICATIONS: All except du, dl, ci, sc, scr

INDICATORS: (Indicators not listed are not affected)

Zero If C(AQ) = 0, then ON; otherwise OFF

Negative If C(AQ)₀ = 1, then ON; otherwise OFF

ldi	Load Indicator Register	634 (0)
-----	-------------------------	---------

FORMAT: Basic instruction format (see Figure 4-1).

SUMMARY: $C(Y)_{18,31} \rightarrow C(IR)$

MODIFICATIONS: All except ci, sc, scr

INDICATORS: (Indicators not listed are not affected)

Parity mask If $C(Y)_{27} = 1$, and the processor is in absolute or privileged mode, then ON; otherwise OFF. This indicator is not affected in the normal or BAR modes.

Not BAR mode Cannot be changed by the ldi instruction

Mid instruction interrupt fault If $C(Y)_{30} = 1$, and the processor is in absolute or privileged mode, then ON; otherwise OFF. This indicator is not affected in normal or BAR modes.

Absolute mode Cannot be changed by the ldi instruction

All other indicators If corresponding bit in $C(Y)$ is 1, then ON; otherwise, OFF

NOTES: The relation between $C(Y)_{18,31}$ and the indicators is given in Table 4-5 below.

The tally runout indicator reflects $C(Y)_{25}$ regardless of what address modification is performed on the ldi instruction.

Attempted repetition with the rpt, rpd, or rpl instructions causes an illegal procedure fault.

Table 4-5. Relation Between Data Bits and Indicators

Bit Position C(Y)	Indicator
18	Zero
19	Negative
20	Carry
21	Overflow
22	Exponent overflow
23	Exponent underflow
24	Overflow mask
25	Tally runout
26	Parity error
27	Parity mask
28	Not BAR mode
29	Truncation
30	Mid instruction interrupt fault
31	Absolute mode

ldq	Load Q	236 (0)
-----	--------	---------

FORMAT: Basic instruction format (see Figure 4-1).

SUMMARY: C(Y) → C(Q)

MODIFICATIONS: All

INDICATORS: (Indicators not listed are not affected)

Zero If C(Q) = 0, then ON; otherwise OFF

Negative If C(Q)₀ = 1, then ON; otherwise OFF

ldqc	Load Q and Clear	032 (0)
------	------------------	---------

FORMAT: Basic instruction format (see Figure 4-1).

SUMMARY: C(Y) → C(Q)
00...0 → C(Y)

MODIFICATIONS: All except du, dl, ci, sc, scr

INDICATORS: (Indicators not listed are not affected)

Zero If $C(Y) = 0$, then ON; otherwise OFF

Negative If $C(Y)_0 = 1$, then ON, otherwise OFF

NOTES: The `ldqc` instruction causes a special main memory reference that performs the load and clear in one cycle. Thus, this instruction can be used in locking data.

<u>ldxn</u>	Load Index Register <u>n</u>	22 <u>n</u> (0)
-------------	------------------------------	-----------------

FORMAT: Basic instruction format (see Figure 4-1).

SUMMARY: For $n = 0, 1, \dots, \text{ or } 7$ as determined by operation code
 $C(Y)_{0,17} \rightarrow C(Xn)$

MODIFICATIONS: All except `ci`, `sc`, `scr`

INDICATORS: (Indicators not listed are not affected)

Zero If $C(Xn) = 0$, then ON; otherwise OFF

Negative If $C(Xn)_0 = 1$, then ON; otherwise OFF

NOTES: Attempted repetition with the `rpl` instruction with the same register given as target and modifier causes an illegal procedure fault.

<u>lreg</u>	Load Registers	073 (0)
-------------	----------------	---------

FORMAT: Basic instruction format (see Figure 4-1).

SUMMARY: $C(Y\text{-block}8)_{0,17} \rightarrow C(X0)$ $C(Y\text{-block}8)_{18,35} \rightarrow C(X1)$
 $C(Y\text{-block}8+1)_{0,17} \rightarrow C(X2)$ $C(Y\text{-block}8+1)_{18,35} \rightarrow C(X3)$
 $C(Y\text{-block}8+2)_{0,17} \rightarrow C(X4)$ $C(Y\text{-block}8+2)_{18,35} \rightarrow C(X5)$
 $C(Y\text{-block}8+3)_{0,17} \rightarrow C(X6)$ $C(Y\text{-block}8+3)_{18,35} \rightarrow C(X7)$
 $C(Y\text{-block}8+4) \rightarrow C(A)$ $C(Y\text{-block}8+5) \rightarrow C(Q)$
 $C(Y\text{-block}8+6)_{0,7} \rightarrow C(E)$

FIXED-POINT DATA MOVEMENT LOAD

MODIFICATIONS: All except du, dl, ci, sc, scr

INDICATORS: None affected

NOTES: Attempted repetition with the rpt, rpd, or rpl instructions causes an illegal procedure fault.

1x1n	Load Index Register <u>n</u> from Lower	72n (0)
------	---	---------

FORMAT: Basic instruction format (see Figure 4-1).

SUMMARY: For n = 0, 1, ..., or 7 as determined by operation code
 $C(Y)_{18,35} \rightarrow C(Xn)$

MODIFICATIONS: All except ci, sc, scr

INDICATORS: (Indicators not listed are not affected)

Zero If $C(Xn) = 0$, then ON; otherwise OFF

Negative If $C(Xn)_0 = 1$, then ON; otherwise OFF

NOTES: Attempted repetition with the rpl instruction with the same register given as target and modifier causes an illegal procedure fault.

Fixed-Point Data Movement Store

sreg	Store Registers	753 (0)
------	-----------------	---------

FORMAT: Basic instruction format (see Figure 4-1).

SUMMARY: C(X0) -> C(Y-block8)_{0,17} C(X1) -> C(Y-block8)_{18,35}
C(X2) -> C(Y-block8+1)_{0,17} C(X3) -> C(Y-block8+1)_{18,35} |
C(X6) -> C(Y-block8+3)_{0,17} C(X7) -> C(Y-block8+3)_{18,35}
C(A) -> C(Y-block8+4) C(Q) -> C(Y-block8+5)
C(E) -> C(Y-block8+6)_{0,7} 00...0 -> C(Y-block8+6)_{8,35}
C(TR) -> C(Y-block8+7)_{0,26} 00...0 -> C(Y-block8+7)_{27,32}
C(RALR) -> C(Y-block8+7)_{33,35}

MODIFICATIONS: All except du, dl, ci, sc, scr

INDICATORS: None affected

NOTES: Attempted repetition with the rpt, rpd, or rpl instructions causes an illegal procedure fault.

FIXED-POINT DATA MOVEMENT STORE

sta	Store A	755 (0)
-----	---------	---------

FORMAT: Basic instruction format (see Figure 4-1).

SUMMARY: C(A) -> C(Y)

MODIFICATIONS: All except du, dl

INDICATORS: None affected

NOTES: Attempted repetition with the rpl instruction causes an illegal procedure fault.

stac	Store A Conditional	354 (0)
------	---------------------	---------

FORMAT: Basic instruction format (see Figure 4-1).

SUMMARY: If C(Y) = 0, then C(A) -> C(Y)

MODIFICATIONS: All except du, dl, ci, sc, scr

INDICATORS: (Indicators not listed are not affected)

Zero If initial C(Y) = 0, then ON; otherwise OFF

NOTES: If the initial C(Y) is nonzero, then C(Y) is not changed by the stac instruction.

The stac instruction uses a special main memory reference that prohibits such references by other processors between the test and the data transfer. Thus, it may be used for data locking.

Attempted repetition with the rpl instruction causes an illegal procedure fault.

stacq	Store A Conditional on Q	654 (0)
-------	--------------------------	---------

FORMAT: Basic instruction format (see Figure 4-1).

SUMMARY: If $C(Y) = C(Q)$, then $C(A) \rightarrow C(Y)$

MODIFICATIONS: All except du, dl, ci, sc, scr

INDICATORS: (Indicators not listed are not affected)

Zero If initial $C(Y) = C(Q)$, then ON; otherwise OFF

NOTES: If the initial $C(Y)$ is $\neq C(Q)$, then $C(Y)$ is not changed by the stacq instruction.

The stacq instruction uses a special main memory reference that prohibits such references by other processors between the test and the data transfer. Thus, it may be used for shared data locking and unlocking.

On the DPS 8M processor, data shared by more than one processor may, at any time, be in more than one processor's cache memory. To aid the integrity of shared data, the stacq instruction will always bypass cache and obtain its operand from main memory. In addition, a synchronizing function inhibits completion of the stacq instruction until the processor executing the stacq instruction is notified by the scu that write completes have occurred and write notifications requesting cache block clears have been sent to the other processors for all write instructions that the processor previously issued. This feature, therefore, makes the stacq instruction the preferred choice for unlocking shared data bases.

Attempted repetition with the rpl instruction causes an illegal procedure fault.

staq	Store AQ	757 (0)
------	----------	---------

FORMAT: Basic instruction format (see Figure 4-1).

SUMMARY: $C(AQ) \rightarrow C(Y\text{-pair})$

MODIFICATIONS: All except du, dl, ci, sc, scr

INDICATORS: None affected

NOTES: Attempted repetition with the rpl instruction causes an illegal procedure fault.

FIXED-POINT DATA MOVEMENT STORE

stba	Store Bytes of A	551(0)
------	------------------	--------

FORMAT: Basic instruction format (see Figure 4-1).

SUMMARY: 9-bit bytes of C(A) -> corresponding bytes of C(Y), the byte positions affected being specified in the TAG field.

MODIFICATIONS: None (see NOTES below)

INDICATORS: None affected

NOTES: Binary ones in the TAG field of this instruction specify the byte positions of A and Y that are affected. The control relations are shown in Table 4-6.

ALM treats a given numeric TAG field for this instruction as an octal number.

Attempted repetition with the rpt, rpd, or rpl instructions causes an illegal procedure fault.

Table 4-6. Control Relations for Store Byte Instructions (9-Bit)

Bit position within TAG field	Bit of instruction	Byte of A and Y
0	30	Byte 0 (bits 0-8)
1	31	Byte 1 (bits 9-17)
2	32	Byte 2 (bits 18-26)
3	33	Byte 3 (bits 27-35)

stbq	Store Bytes of Q	552 (0)
------	------------------	---------

FORMAT: Basic instruction format (see Figure 4-1).

SUMMARY: 9-bit bytes of C(Q) → corresponding bytes of C(Y), the byte positions affected being specified in the TAG field.

MODIFICATIONS: None (see NOTES below)

INDICATORS: None affected

NOTES: Binary ones in the TAG field of this instruction specify the byte positions of Q and Y that are affected. The control relations are shown in Table 4-6 above.

ALM treats a given numeric TAG field for this instruction as an octal number.

Attempted repetition with the rpt, rpd, or rpl instructions causes an illegal procedure fault.

stc1	Store Instruction Counter Plus 1	554 (0)
------	----------------------------------	---------

FORMAT: Basic instruction format (see Figure 4-1).

SUMMARY: C(PPR.IC) + 1 → C(Y)_{0,17}
C(IR) → C(Y)_{18,31}
00...0 → C(Y)_{32,35}

MODIFICATIONS: All except du, dl, ci, sc, scr

INDICATORS: None affected

NOTES: The contents of the instruction counter C(PPR.IC) and the indicator register (IR) after address preparation are stored in C(Y)_{0,17} and C(Y)_{18,31}, respectively. C(Y)₂₅ reflects the state of the tally runout indicator prior to modification. The relations between C(Y)_{18,31} and the indicators are given in Table 4-5.

Attempted repetition with the rpt, rpd, or rpl instructions causes an illegal procedure fault.

FIXED-POINT DATA MOVEMENT STORE

stc2	Store Instruction Counter Plus 2	750 (0)
------	----------------------------------	---------

FORMAT: Basic instruction format (see Figure 4-1).

SUMMARY: $C(\text{PPR.IC}) + 2 \rightarrow C(Y)_{0,17}$

MODIFICATIONS: All except du, dl, ci, sc, scr

INDICATORS: None affected

NOTES: The contents of the instruction counter $C(\text{PPR.IC})$ are stored in $C(Y)_{0,17}$.

Attempted repetition with the rpt, rpd, or rpl instructions causes an illegal procedure fault.

stca	Store Characters of A	751 (0)
------	-----------------------	---------

FORMAT: Basic instruction format (see Figure 4-1).

SUMMARY: Characters of $C(A)$ \rightarrow corresponding characters of $C(Y)$, the character positions affected being specified in the TAG field.

MODIFICATIONS: None (see NOTES below)

INDICATORS: None affected

NOTES: Binary ones in the TAG field of this instruction specify character positions of A and Y that are affected. The control relations are shown in Table 4-7.

ALM treats a given numeric TAG field for this instruction as an octal number.

Attempted repetition with the rpt, rpd, or rpl instructions causes an illegal procedure fault.

Table 4-7. Control Relations for Store Character Instructions (6-Bit)

Bit position within TAG field	Bit of instruction	Character of A and Y
0	30	Char 0 (bits 0-5)
1	31	Char 1 (bits 6-11)
2	32	Char 2 (bits 12-17)
3	33	Char 3 (bits 18-23)
4	34	Char 4 (bits 24-29)
5	35	Char 5 (bits 30-35)

stcq	Store Characters of Q	752 (0)
------	-----------------------	---------

FORMAT: Basic instruction format (see Figure 4-1).

SUMMARY: Characters of C(Q) → corresponding characters of C(Y), the character positions affected being specified by the TAG field.

MODIFICATIONS: None (see NOTES below)

INDICATORS: None affected

NOTES: Binary ones in the TAG field of this instruction specify the character positions of Q and Y that are affected. The control relations are shown in Table 4-7 above.

ALM treats a given numeric TAG field for this instruction as an octal number.

Attempted repetition with the rpt, rpd, or rpl instructions causes an illegal procedure fault.

FIXED-POINT DATA MOVEMENT STORE

stcd	Store Control Double	357 (0)
------	----------------------	---------

FORMAT: Basic instruction format (see Figure 4-1).

SUMMARY: C(PPR) -> C(Y-pair) as follows:

- 000 -> C(Y-pair)_{0,2}
- C(PPR.PSR) -> C(Y-pair)_{3,17}
- C(PPR.PRR) -> C(Y-pair)_{18,20}
- 00...0 -> C(Y-pair)_{21,29}
- (43)₈ -> C(Y-pair)_{30,35}
- C(PPR.IC)+2 -> C(Y-pair)_{36,53}
- 00...0 -> C(Y-pair)_{54,71}

MODIFICATIONS: All except du, dl, ci, sc, scr

INDICATORS: None affected

NOTES: Attempted repetition with the rpt, rpd, or rpl instructions causes an illegal procedure fault.

sti	Store Indicator Register	754 (0)
-----	--------------------------	---------

FORMAT: Basic instruction format (see Figure 4-1).

SUMMARY: C(IR) -> C(Y)_{18,31}

00...0 -> C(Y)_{32,35}

MODIFICATIONS: All except du, dl, ci, sc, scr

INDICATORS: None affected

NOTES: The contents of the indicator register after address preparation are stored in C(Y)_{18,31}. C(Y)_{18,31} reflects the state of the tally runout indicator prior to address preparation. The relation between C(Y)_{18,31} and the indicators is given in Table 4-5.

Attempted repetition with the rpt, rpd, or rpl instructions causes an illegal procedure fault.

stq	Store Q	756 (0)
-----	---------	---------

FORMAT: Basic instruction format (see Figure 4-1).

SUMMARY: C(Q) → C(Y)

MODIFICATIONS: All except du, dl

INDICATORS: None affected

NOTES: Attempted repetition with the rpl instruction causes an illegal procedure fault.

stt	Store Time Register	454 (0)
-----	---------------------	---------

FORMAT: Basic instruction format (see Figure 4-1).

SUMMARY: C(TR) → C(Y)_{0,26}
00...0 → C(Y)_{27,35}

MODIFICATIONS: All except du, dl, ci, sc, scr

INDICATORS: None affected

NOTES: Attempted repetition with the rpt, rpd, or rpl instructions causes an illegal procedure fault.

FIXED-POINT DATA MOVEMENT STORE

<u>stxn</u>	Store Index Register <u>n</u>	<u>74n</u> (0)
-------------	-------------------------------	----------------

FORMAT: Basic instruction format (see Figure 4-1).

SUMMARY: For $n = 0, 1, \dots, \text{or } 7$ as determined by operation code
 $C(Xn) \rightarrow C(Y)_{0,17}$.

MODIFICATIONS: All except du, dl, ci, sc, scr

INDICATORS: None affected

NOTES: Attempted repetition with the rpl instruction causes an illegal procedure fault.

<u>stz</u>	Store Zero	<u>450</u> (0)
------------	------------	----------------

FORMAT: Basic instruction format (see Figure 4-1).

SUMMARY: $00\dots0 \rightarrow C(Y)$

MODIFICATIONS: All except du, dl

INDICATORS: None affected

NOTES: Attempted repetition with the rpl instruction causes an illegal procedure fault.

<u>sxln</u>	Store Index Register <u>n</u> in Lower	<u>44n</u> (0)
-------------	--	----------------

FORMAT: Basic instruction format (see Figure 4-1).

SUMMARY: For $n = 0, 1, \dots, \text{or } 7$ as determined by operation code
 $C(Xn) \rightarrow C(Y)_{18,35}$

MODIFICATIONS: All except du, dl, ci, sc, scr

INDICATORS: None affected

NOTES: Attempted repetition with the rpl instruction causes an illegal procedure fault.

FIXED-POINT DATA MOVEMENT SHIFT

Fixed-Point Data Movement Shift

alr	A Left Rotate	775 (0)
-----	---------------	---------

FORMAT: Basic instruction format (see Figure 4-1).

SUMMARY: Shift C(A) left the number of positions given in C(TPR.CA)_{11,17}; entering each bit leaving A₀ into A₃₅.

MODIFICATIONS: All except du, dl, ci, sc, scr

INDICATORS: (Indicators not listed are not affected)

Zero If C(A) = 0, then ON; otherwise OFF

Negative If C(A)₀ = 1, then ON; otherwise OFF

NOTES: Attempted repetition with the rpl instruction causes an illegal procedure fault.

als	A Left Shift	735 (0)
-----	--------------	---------

FORMAT: Basic instruction format (see Figure 4-1).

SUMMARY: Shift C(A) left the number of positions given in by C(TPR.CA)_{11,17}; filling vacated positions with zeros.

MODIFICATIONS: All except du, dl, ci, sc, scr

INDICATORS: (Indicators not listed are not affected)

Zero If C(A) = 0, then ON; otherwise OFF

Negative If C(A)₀ = 1, then ON; otherwise OFF

Carry If C(A)₀ changes during the shift, then ON; otherwise OFF

NOTES: Attempted repetition with the rpl instruction causes an illegal procedure fault.

arl	A Right Logical	771 (0)
-----	-----------------	---------

FORMAT: Basic instruction format (see Figure 4-1).

SUMMARY: Shift $C(A)$ right the number of positions given in $C(TPR.CA)_{11,17}$; filling vacated positions with zeros.

MODIFICATIONS: All except du, dl, ci, sc, scr

INDICATORS: (Indicators not listed are not affected)

Zero If $C(A) = 0$, then ON; otherwise OFF

Negative If $C(A)_0 = 1$, then ON; otherwise OFF

NOTES: Attempted repetition with the rpl instruction causes an illegal procedure fault.

ars	A Right Shift	731 (0)
-----	---------------	---------

FORMAT: Basic instruction format (see Figure 4-1).

SUMMARY: Shift $C(A)$ right the number of positions given in $C(TPR.CA)_{11,17}$; filling vacated positions with initial $C(A)_0$.

MODIFICATIONS: All except du, dl, ci, sc, scr

INDICATORS: (Indicators not listed are not affected)

Zero If $C(A) = 0$, then ON; otherwise OFF

Negative If $C(A)_0 = 1$, then ON; otherwise OFF

NOTES: Attempted repetition with the rpl instruction causes an illegal procedure fault.

FIXED-POINT DATA MOVEMENT SHIFT

1lr	Long Left Rotate	777 (0)
-----	------------------	---------

FORMAT: Basic instruction format (see Figure 4-1).
SUMMARY: Shift C(AQ) left by the number of positions given in C(TPR.CA)_{11,17}; entering each bit leaving AQ₀ into AQ₇₁.
MODIFICATIONS: All except du, dl, ci, sc, scr
INDICATORS: (Indicators not listed are not affected)
 Zero If C(AQ) = 0, then ON; otherwise OFF
 Negative If C(AQ)₀ = 1, then ON; otherwise OFF
NOTES: Attempted repetition with the rpl instruction causes an illegal procedure fault.

1ls	Long Left Shift	737 (0)
-----	-----------------	---------

FORMAT: Basic instruction format (see Figure 4-1).
SUMMARY: Shift C(AQ) left the number of positions given in C(TPR.CA)_{11,17}; filling vacated positions with zeros.
MODIFICATIONS: All except du, dl, ci, sc, scr
INDICATORS: (Indicators not listed are not affected)
 Zero If C(AQ) = 0, then ON; otherwise OFF
 Negative If C(AQ)₀ = 1, then ON; otherwise OFF
 Carry If C(AQ)₀ changes during the shift, then ON; otherwise OFF
NOTES: Attempted repetition with the rpl instruction causes an illegal procedure fault.

lrl	Long Right Logical	773 (0)
-----	--------------------	---------

FORMAT: Basic instruction format (see Figure 4-1).

SUMMARY: Shift C(AQ) right the number of positions given in C(TPR.CA)_{11,17}; filling vacated positions with zeros.

MODIFICATIONS: All except du, dl, ci, sc, scr

INDICATORS: (Indicators not listed are not affected)

Zero If C(AQ) = 0, then ON; otherwise OFF

Negative If C(AQ)₀ = 1, then ON; otherwise OFF

NOTES: Attempted repetition with the rpl instruction causes an illegal procedure fault.

lrs	Long Right Shift	733 (0)
-----	------------------	---------

FORMAT: Basic instruction format (see Figure 4-1).

SUMMARY: Shift C(AQ) right the number of positions given in C(TPR.CA)_{11,17}; filling vacated positions with initial C(AQ)₀.

MODIFICATIONS: All except du, dl, ci, sc, scr

INDICATORS: (Indicators not listed are not affected)

Zero If C(AQ) = 0, then ON; otherwise OFF

Negative If C(AQ)₀ = 1, then ON; otherwise OFF

NOTES: Attempted repetition with the rpl instruction causes an illegal procedure fault.

FIXED-POINT DATA MOVEMENT SHIFT

qlr	Q Left Rotate	776 (0)
-----	---------------	---------

FORMAT: Basic instruction format (see Figure 4-1).

SUMMARY: Shift C(Q) left the number of positions given in C(TPR.CA)_{11,17}; entering each bit leaving Q₀ into Q₃₅.

MODIFICATIONS: All except du, dl, ci, sc, scr

INDICATORS: (Indicators not listed are not affected)

Zero If C(Q) = 0, then ON; otherwise OFF

Negative If C(Q)₀ = 1, then ON; otherwise OFF

NOTES: Attempted repetition with the rpl instruction causes an illegal procedure fault.

qls	Q Left Shift	736 (0)
-----	--------------	---------

FORMAT: Basic instruction format (see Figure 4-1).

SUMMARY: Shift C(Q) left the number of positions given in C(TPR.CA)_{11,17}; fill vacated positions with zeros.

MODIFICATIONS: All except du, dl, ci, sc, scr

INDICATORS: (Indicators not listed are not affected)

Zero If C(Q) = 0, then ON; otherwise OFF

Negative If C(Q)₀ = 1, then ON; otherwise OFF

Carry If C(Q)₀ changes during the shift, then ON; otherwise OFF

NOTES: Attempted repetition with the rpl instruction causes an illegal procedure fault.

qrl	Q Right Logical	772 (0)
-----	-----------------	---------

FORMAT: Basic instruction format (see Figure 4-1).

SUMMARY: Shift $C(Q)$ right the number of positions specified by $Y_{11,17}$; fill vacated positions with zeros.

MODIFICATIONS: All except du, dl, ci, sc, scr

INDICATORS: (Indicators not listed are not affected)

Zero If $C(Q) = 0$, then ON; otherwise OFF

Negative If $C(Q)_0 = 1$, then ON; otherwise OFF

NOTES: Attempted repetition with the rpl instruction causes an illegal procedure fault.

qrs	Q Right Shift	732 (0)
-----	---------------	---------

FORMAT: Basic instruction format (see Figure 4-1).

SUMMARY: Shift $C(Q)$ right the number of positions given in $C(TPR.CA)_{11,17}$; filling vacated positions with initial $C(Q)_0$.

MODIFICATIONS: All except du, dl, ci, sc, scr

INDICATORS: (Indicators not listed are not affected)

Zero If $C(Q) = 0$, then ON; otherwise OFF

Negative If $C(Q)_0 = 1$, then ON; otherwise OFF

NOTES: Attempted repetition with the rpl instruction causes an illegal procedure fault.

FIXED-POINT ADDITION

Fixed-Point Addition

ada	Add to A	075 (0)
-----	----------	---------

FORMAT: Basic instruction format (see Figure 4-1).

SUMMARY: $C(A) + C(Y) \rightarrow C(A)$

MODIFICATIONS: All

INDICATORS: (Indicators not listed are not affected)

- Zero If $C(A) = 0$, then ON; otherwise OFF
- Negative If $C(A)_0 = 1$, then ON; otherwise OFF
- Overflow If range of A is exceeded, then ON
- Carry If a carry out of A_0 is generated, then ON; otherwise OFF

adaq	Add to AQ	077 (0)
------	-----------	---------

FORMAT: Basic instruction format (see Figure 4-1).

SUMMARY: $C(AQ) + C(Y\text{-pair}) \rightarrow C(AQ)$

MODIFICATIONS: All except du, dl, ci, sc, scr

INDICATORS: (Indicators not listed are not affected)

- Zero If $C(AQ) = 0$, then ON; otherwise OFF
- Negative If $C(AQ)_0 = 1$, then ON; otherwise OFF
- Overflow If range of AQ is exceeded, then ON
- Carry If a carry out of AQ_0 is generated, then ON; otherwise OFF

adl	Add Low to AQ	033 (0)
-----	---------------	---------

FORMAT: Basic instruction format (see Figure 4-1).

SUMMARY: $C(AQ) + C(Y)$ sign extended $\rightarrow C(AQ)$

MODIFICATIONS: All except ci, sc, scr

INDICATORS: (Indicators not listed are not affected)

Zero If $C(AQ) = 0$, then ON; otherwise OFF

Negative If $C(AQ)_0 = 1$, then ON; otherwise OFF

Overflow If range of AQ is exceeded, then ON

Carry If a carry out of AQ_0 is generated, then ON; otherwise OFF

NOTES: A 72-bit number is formed from $C(Y)$ in the following manner:

The lower 36 bits (36,71) are identical to $C(Y)$.
Each of the upper 36 bits (0,35) is identical to $C(Y)_0$.

This 72-bit number is added to the contents of the combined AQ-register.

adla	Add Logical to A	035 (0)
------	------------------	---------

FORMAT: Basic instruction format (see Figure 4-1).

SUMMARY: $C(A) + C(Y) \rightarrow C(A)$

MODIFICATIONS: All

INDICATORS: (Indicators not listed are not affected)

Zero If $C(A) = 0$, then ON; otherwise OFF

Negative If $C(A)_0 = 1$, then ON; otherwise OFF

Carry If a carry out of A_0 is generated, then ON; otherwise OFF

NOTES: The adla instruction is identical to the ada instruction with the exception that the overflow indicator is not

FIXED-POINT ADDITION

affected by the adla instruction, nor does an overflow fault occur. Operands and results are treated as unsigned, positive binary integers.

adlaq	Add Logical to AQ	037 (0)
-------	-------------------	---------

FORMAT: Basic instruction format (see Figure 4-1).

SUMMARY: $C(AQ) + C(Y\text{-pair}) \rightarrow C(AQ)$

MODIFICATIONS: All except du, dl, ci, sc, scr

INDICATORS: (Indicators not listed are not affected)

Zero If $C(AQ) = 0$, then ON; otherwise OFF

Negative If $C(AQ)_0 = 1$, then ON; otherwise OFF

Carry If a carry out of AQ_0 is generated, then ON; otherwise OFF

NOTES: The adlaq instruction is identical to the adaq instruction with the exception that the overflow indicator is not affected by the adlaq instruction, nor does an overflow fault occur. Operands and results are treated as unsigned, positive binary integers.

adlq	Add Logical to Q	036 (0)
------	------------------	---------

FORMAT: Basic instruction format (see Figure 4-1).

SUMMARY: $C(Q) + C(Y) \rightarrow C(Q)$

MODIFICATIONS: All

INDICATORS: (Indicators not listed are not affected)

Zero If $C(Q) = 0$, then ON; otherwise OFF

Negative If $C(Q)_0 = 1$, then ON; otherwise OFF

Carry If a carry out of Q_0 is generated, then ON; otherwise OFF

NOTES: The adlq instruction is identical to the adq instruction with the exception that the overflow indicator is not affected by the adlq instruction, nor does an overflow

fault occur. Operands and results are treated as unsigned, positive binary integers.

<u>adl_{xn}</u>	Add Logical to Index Register <u>n</u>	02 <u>n</u> (0)
-------------------------	--	-----------------

FORMAT: Basic instruction format (see Figure 4-1).

SUMMARY: For $n = 0, 1, \dots, \text{or } 7$ as determined by operation code
 $C(X_n) + C(Y)_{0,17} \rightarrow C(X_n)$

MODIFICATIONS: All except *ci*, *sc*, *scr*

INDICATORS: (Indicators not listed are not affected)

Zero If $C(X_n) = 0$, then ON; otherwise OFF

Negative If $C(X_n)_0 = 1$, then ON; otherwise OFF

Carry If a carry out of X_{n0} is generated, then ON; otherwise OFF

NOTES: The adl_{xn} instruction is identical to the ad_{xn} instruction with the exception that the overflow indicator is not affected by the adl_{xn} instruction, nor does an overflow fault occur. Operands and results are treated as unsigned, positive binary integers.

<u>adq</u>	Add to Q	076 (0)
------------	----------	---------

FORMAT: Basic instruction format (see Figure 4-1).

SUMMARY: $C(Q) + C(Y) \rightarrow C(Q)$

MODIFICATIONS: All

INDICATORS: (Indicators not listed are not affected)

Zero If $C(Q) = 0$, then ON; otherwise OFF

Negative If $C(Q)_0 = 1$, then ON; otherwise OFF

Overflow If range of Q is exceeded, then ON

Carry If a carry out of Q_0 is generated, then ON; otherwise OFF

FIXED-POINT ADDITION

adxn	Add to Index Register <u>n</u>	06n (0)
------	--------------------------------	---------

FORMAT: Basic instruction format (see Figure 4-1).

SUMMARY: For $n = 0, 1, \dots, \text{or } 7$ as determined by operation code
 $C(X_n) + C(Y)_{0,17} \rightarrow C(X_n)$

MODIFICATIONS: All except ci, sc, scr

INDICATORS: (Indicators not listed are not affected)

Zero If $C(X_n) = 0$, then ON; otherwise OFF

Negative If $C(X_n)_0 = 1$, then ON; otherwise OFF

Overflow If range of X_n is exceeded, then ON

Carry If a carry out of X_{n0} is generated, then ON; otherwise OFF

aos	Add One to Storage	054 (0)
-----	--------------------	---------

FORMAT: Basic instruction format (see Figure 4-1).

SUMMARY: $C(Y) + 1 \rightarrow C(Y)$

MODIFICATIONS: All except du, dl, ci, sc, scr

INDICATORS: (Indicators not listed are not affected)

Zero If $C(Y) = 0$, then ON; otherwise OFF

Negative If $C(Y)_0 = 1$, then ON; otherwise OFF

Overflow If range of Y is exceeded, then ON

Carry If a carry out of Y_0 is generated, then ON; otherwise OFF

NOTES: Attempted repetition with the rpl instruction causes an illegal procedure fault.

asa	Add Stored to A	055 (0)
-----	-----------------	---------

FORMAT: Basic instruction format (see Figure 4-1).

SUMMARY: $C(A) + C(Y) \rightarrow C(Y)$

MODIFICATIONS: All except du, dl, ci, sc, scr

INDICATORS: (Indicators not listed are not affected)

Zero If $C(Y) = 0$, then ON; otherwise OFF

Negative If $C(Y)_0 = 1$, then ON; otherwise OFF

Overflow If range of Y is exceeded, then ON

Carry If a carry out of Y_0 is generated, then ON; otherwise OFF

NOTES: Attempted repetition with the rpl instruction causes an illegal procedure fault.

asq	Add Stored to Q	056 (0)
-----	-----------------	---------

FORMAT: Basic instruction format (see Figure 4-1).

SUMMARY: $C(Q) + C(Y) \rightarrow C(Y)$

MODIFICATIONS: All except du, dl, ci, sc, scr

INDICATORS: (Indicators not listed are not affected)

Zero If $C(Y) = 0$, then ON; otherwise OFF

Negative If $C(Y)_0 = 1$, then ON; otherwise OFF

Overflow If range of Y is exceeded, then ON

Carry If a carry out of Y_0 is generated, then ON; otherwise OFF

NOTES: Attempted repetition with the rpl instruction causes an illegal procedure fault.

asxn	Add Stored to Index Register <u>n</u>	04 <u>n</u> (0)
------	---------------------------------------	-----------------

FORMAT: Basic instruction format (see Figure 4-1).

FIXED-POINT ADDITION

SUMMARY: For $n = 0, 1, \dots, \text{ or } 7$ as determined by operation code
 $C(X_n) + C(Y)_{0,17} \rightarrow C(Y)_{0,17}$

MODIFICATIONS: All except du, dl, ci, sc, scr

INDICATORS: (Indicators not listed are not affected)

- Zero If $C(Y)_{0,17} = 0$, then ON; otherwise OFF
- Negative If $C(Y)_0 = 1$, then ON; otherwise OFF
- Overflow If range of $Y_{0,17}$ is exceeded, then ON
- Carry If a carry out of Y_0 is generated, then ON; otherwise OFF

NOTES: Attempted repetition with the rpl instruction causes an illegal procedure fault.

awca	Add with Carry to A	071 (0)
------	---------------------	---------

FORMAT: Basic instruction format (see Figure 4-1).

SUMMARY: If carry indicator OFF, then $C(A) + C(Y) \rightarrow C(A)$
 If carry indicator ON, then $C(A) + C(Y) + 1 \rightarrow C(A)$

MODIFICATIONS: All

INDICATORS: (Indicators not listed are not affected)

- Zero If $C(A) = 0$, then ON; otherwise OFF
- Negative If $C(A)_0 = 1$, then ON; otherwise OFF
- Overflow If range of A is exceeded, then ON
- Carry If a carry out of A_0 is generated, then ON; otherwise OFF

NOTES: The awca instruction is identical to the ada instruction with the exception that when the carry indicator is ON at the beginning of the instruction, 1 is added to the sum of $C(A)$ and $C(Y)$.

awcq	Add with Carry to Q	072 (0)
------	---------------------	---------

FORMAT: Basic instruction format (see Figure 4-1).

SUMMARY: If carry indicator OFF, then $C(Q) + C(Y) \rightarrow C(Q)$
 If carry indicator ON, then $C(Q) + C(Y) + 1 \rightarrow C(Q)$

MODIFICATIONS: All

INDICATORS: (Indicators not listed are not affected)

Zero	If $C(Q) = 0$, then ON; otherwise OFF
Negative	If $C(Q)_0 = 1$, then ON; otherwise OFF
Overflow	If range of Q is exceeded, then ON
Carry	If a carry out of Q_0 is generated, then ON; otherwise OFF

NOTES: The awcq instruction is identical to the adq instruction with the exception that when the carry indicator is ON at the beginning of the instruction, 1 is added to the sum of $C(Q)$ and $C(Y)$.

FIXED-POINT SUBTRACTION

Fixed-Point Subtraction

sba	Subtract from A	175 (0)
-----	-----------------	---------

FORMAT: Basic instruction format (see Figure 4-1).

SUMMARY: $C(A) - C(Y) \rightarrow C(A)$

MODIFICATIONS: All

INDICATORS: (Indicators not listed are not affected)

Zero If $C(A) = 0$, then ON; otherwise OFF

Negative If $C(A)_0 = 1$, then ON; otherwise OFF

Overflow If range of A is exceeded, then ON

Carry If a carry out of A_0 is generated, then ON; otherwise OFF

sbaq	Subtract from AQ	177 (0)
------	------------------	---------

FORMAT: Basic instruction format (see Figure 4-1).

SUMMARY: $C(AQ) - C(Y\text{-pair}) \rightarrow C(AQ)$

MODIFICATIONS: All except du, dl, ci, sc, scr

INDICATORS: (Indicators not listed are not affected)

Zero If $C(AQ) = 0$, then ON; otherwise OFF

Negative If $C(AQ)_0 = 1$, then ON; otherwise OFF

Overflow If range of AQ is exceeded, then ON

Carry If a carry out of AQ_0 is generated, then ON; otherwise OFF

sbla	Subtract Logical from A	135 (0)
------	-------------------------	---------

FORMAT: Basic instruction format (see Figure 4-1).

SUMMARY: $C(A) - C(Y) \rightarrow C(A)$

MODIFICATIONS: All

INDICATORS: (Indicators not listed are not affected)

Zero If $C(A) = 0$, then ON; otherwise OFF

Negative If $C(A)_0 = 1$, then ON; otherwise OFF

Carry If a carry out of A_0 is generated, then ON; otherwise OFF

NOTES: The sbla instruction is identical to the sba instruction with the exception that the overflow indicator is not affected by the sbla instruction, nor does an overflow fault occur. Operands and results are treated as unsigned, positive binary integers.

sblaq	Subtract Logical from AQ	137 (0)
-------	--------------------------	---------

FORMAT: Basic instruction format (see Figure 4-1).

SUMMARY: $C(AQ) - C(Y\text{-pair}) \rightarrow C(AQ)$

MODIFICATIONS: All except du, dl, ci, sc, scr

INDICATORS: (Indicators not listed are not affected)

Zero If $C(AQ) = 0$, then ON; otherwise OFF

Negative If $C(AQ)_0 = 1$, then ON; otherwise OFF

Carry If a carry out of AQ_0 is generated, then ON; otherwise OFF

NOTES: The sblaq instruction is identical to the sbaq instruction with the exception that the overflow indicator is not affected by the sblaq instruction, nor does an overflow fault occur. Operands and results are treated as unsigned, positive binary integers.

sblq	Subtract Logical from Q	136 (0)
------	-------------------------	---------

FORMAT: Basic instruction format (see Figure 4-1).

FIXED-POINT SUBTRACTION

SUMMARY: $C(Q) - C(Y) \rightarrow C(Q)$

MODIFICATIONS: All

INDICATORS: (Indicators not listed are not affected)

Zero If $C(Q) = 0$, then ON; otherwise OFF

Negative If $C(Q)_0 = 1$, then ON; otherwise OFF

Carry If a carry out of Q_0 is generated, then ON; otherwise OFF

NOTES: The sblq instruction is identical to the sbq instruction with the exception that the overflow indicator is not affected by the sblq instruction, nor does an overflow fault occur. Operands and results are treated as unsigned, positive binary integers.

<u>sblxn</u>	Subtract Logical from Index Register <u>n</u>	$12n$ (0)
--------------	---	-----------

FORMAT: Basic instruction format (see Figure 4-1).

SUMMARY: For $n = 0, 1, \dots, \text{or } 7$ as determined by operation code
 $C(Xn) - C(Y)_{0,17} \rightarrow C(Xn)$

MODIFICATIONS: All except ci, sc, scr

INDICATORS: (Indicators not listed are not affected)

Zero If $C(Xn) = 0$, then ON; otherwise OFF

Negative If $C(Xn)_0 = 1$, then ON; otherwise OFF

Carry If a carry out of Xn_0 is generated, then ON; otherwise OFF

NOTES: The sblxn instruction is identical to the sbxn instruction with the exception that the overflow indicator is not affected by the sblxn instruction, nor does an overflow fault occur. Operands and results are treated as unsigned, positive binary integers.

<u>sbq</u>	Subtract from Q	176 (0)
------------	-----------------	-----------

FORMAT: Basic instruction format (see Figure 4-1).
SUMMARY: $C(Q) - C(Y) \rightarrow C(Q)$
MODIFICATIONS: All
INDICATORS: (Indicators not listed are not affected)

Zero	If $C(Q) = 0$, then ON; otherwise OFF
Negative	If $C(Q)_0 = 1$, then ON; otherwise OFF
Overflow	If range of Q is exceeded, then ON
Carry	If a carry out of Q_0 is generated, then ON; otherwise OFF

<u>sbxn</u>	Subtract from Index Register <u>n</u>	<u>16n</u> (0)
-------------	---------------------------------------	----------------

FORMAT: Basic instruction format (see Figure 4-1).
SUMMARY: For $n = 0, 1, \dots, \text{or } 7$ as determined by operation code
 $C(Xn) - C(Y)_{0,17} \rightarrow C(Xn)$
MODIFICATIONS: All except ci, sc, scr
INDICATORS: (Indicators not listed are not affected)

Zero	If $C(Xn) = 0$, then ON; otherwise OFF
Negative	If $C(Xn)_0 = 1$, then ON; otherwise OFF
Overflow	If range of Xn is exceeded, then ON
Carry	If a carry out of Xn_0 is generated, then ON; otherwise OFF

<u>ssa</u>	Subtract Stored from A	<u>155</u> (0)
------------	------------------------	----------------

FORMAT: Basic instruction format (see Figure 4-1).
SUMMARY: $C(A) - C(Y) \rightarrow C(Y)$
MODIFICATIONS: All except du, dl, ci, sc, scr

FIXED-POINT SUBTRACTION

INDICATORS: (Indicators not listed are not affected)

Zero If $C(Y) = 0$, then ON; otherwise OFF

Negative If $C(Y)_0 = 1$, then ON; otherwise OFF

Overflow If range of Y is exceeded, then ON

Carry If a carry out of Y_0 is generated, then ON; otherwise OFF

NOTES: Attempted repetition with the rpl instruction causes an illegal procedure fault.

ssq	Subtract Stored from Q	156 (0)
-----	------------------------	---------

FORMAT: Basic instruction format (see Figure 4-1).

SUMMARY: $C(Q) - C(Y) \rightarrow C(Y)$

MODIFICATIONS: All except du, dl, ci, sc, scr

INDICATORS: (Indicators not listed are not affected)

Zero If $C(Y) = 0$, then ON; otherwise OFF

Negative If $C(Y)_0 = 1$, then ON; otherwise OFF

Overflow If range of Y is exceeded, then ON

Carry If a carry out of Y_0 is generated, then ON; otherwise OFF

NOTES: Attempted repetition with the rpl instruction causes an illegal procedure fault.

ssxn	Subtract Stored from Index Register <u>n</u>	14n (0)
------	--	---------

FORMAT: Basic instruction format (see Figure 4-1).

SUMMARY: For $n = 0, 1, \dots, \text{or } 7$ as determined by operation code

$C(X_n) - C(Y)_{0,17} \rightarrow C(Y)_{0,17}$

MODIFICATIONS: All except du, dl, ci, sc, scr

INDICATORS: (Indicators not listed are not affected)

Zero If $C(Y)_{0,17} = 0$, then ON; otherwise OFF
 Negative If $C(Y)_0 = 1$, then ON; otherwise OFF
 Overflow If range of $Y_{0,17}$ exceeded, then ON
 Carry If a carry out of Y_0 is generated, then ON; otherwise OFF

NOTES: Attempted repetition with the rpl instruction causes an illegal procedure fault.

swca	Subtract with Carry from A	171 (0)
------	----------------------------	---------

FORMAT: Basic instruction format (see Figure 4-1).

SUMMARY: If carry indicator ON, then $C(A) - C(Y) \rightarrow C(A)$
 If carry indicator OFF, then $C(A) - C(Y) - 1 \rightarrow C(A)$

MODIFICATIONS: All

INDICATORS: (Indicators not listed are not affected)

Zero If $C(A) = 0$, then ON; otherwise OFF
 Negative If $C(A)_0 = 1$, then ON; otherwise OFF
 Overflow If range of A is exceeded, then ON
 Carry If a carry out of A_0 is generated, then ON; otherwise OFF

NOTES: The swca instruction is identical to the sba instruction with the exception that when the carry indicator is OFF at the beginning of the instruction, +1 is subtracted from the difference of $C(A)$ minus $C(Y)$. The swca instruction treats the carry indicator as the complement of a borrow indicator due to the implementation of negative numbers in twos complement form.

swcq	Subtract with Carry from Q	172 (0)
------	----------------------------	---------

FORMAT: Basic instruction format (see Figure 4-1).

SUMMARY: If carry indicator ON, then $C(Q) - C(Y) \rightarrow C(Q)$
 If carry indicator OFF, then $C(Q) - C(Y) - 1 \rightarrow C(Q)$

FIXED-POINT SUBTRACTION

MODIFICATIONS: All

INDICATORS: (Indicators not listed are not affected)

Zero	If $C(Q) = 0$, then ON; otherwise OFF
Negative	If $C(Q)_0 = 1$, then ON; otherwise OFF
Overflow	If range of Q is exceeded, then ON
Carry	If a carry out of Q_0 is generated, then ON; otherwise OFF

NOTES: The swcq instruction is identical to the sbq instruction with the exception that when the carry indicator is OFF at the beginning of the instruction, +1 is subtracted from the difference of $C(Q)$ minus $C(Y)$. The swcq instruction treats the carry indicator as the complement of a borrow indicator due to the implementation of negative numbers in twos complement form.

Fixed-Point Multiplication

mpf	Multiply Fraction	401 (0)
-----	-------------------	---------

FORMAT: Basic instruction format (see Figure 4-1).

SUMMARY: $C(A) \times C(Y) \rightarrow C(AQ)$, left adjusted

MODIFICATIONS: All except ci, sc, scr

INDICATORS: (Indicators not listed are not affected)

Zero If $C(AQ) = 0$, then ON; otherwise OFF

Negative If $C(AQ)_0 = 1$, then ON; otherwise OFF

Overflow If range of AQ is exceeded, then ON

NOTES: Two 36-bit fractional factors (including sign) are multiplied to form a 71-bit fractional product (including sign), which is stored left-adjusted in the AQ register. AQ_{71} contains a zero. Overflow can occur only in the case of A and Y containing negative 1 and the result exceeding the range of the AQ register.

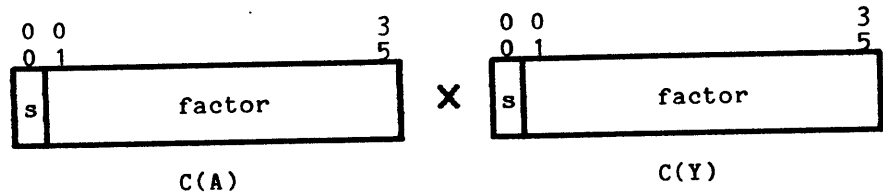

yielding

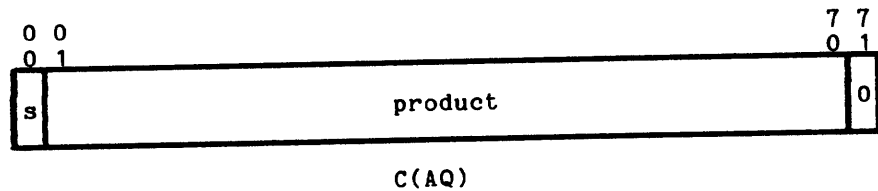

mpy	Multiply Integer	402 (0)
-----	------------------	---------

FORMAT: Basic instruction format (see Figure 4-1).

SUMMARY: $C(Q) \times C(Y) \rightarrow C(AQ)$, right adjusted

FIXED-POINT MULTIPLICATION

MODIFICATIONS: All except ci, sc, scr

INDICATORS: (Indicators not listed are not affected)

Zero If C(AQ) = 0, then ON; otherwise OFF

Negative If C(AQ)₀ = 1, then ON; otherwise OFF

NOTES: Two 36-bit integer factors (including sign) are multiplied to form a 71-bit integer product (including sign), which is stored right-adjusted in the AQ-register. AQ₀ is filled with an "extended sign bit".

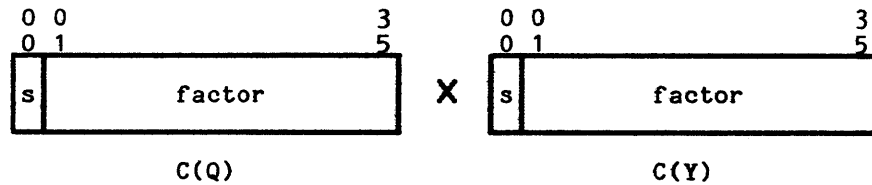

yielding

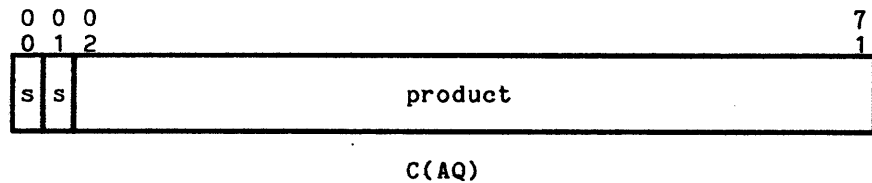

In the case of $(-2^{35}) \times (-2^{35}) = +2^{70}$, AQ₁ is used to represent the product rather than the sign. No overflow can occur.

Fixed-Point Division

div	Divide Integer	506 (0)
-----	----------------	---------

FORMAT: Basic instruction format (see Figure 4-1).

SUMMARY: $C(Q) / (Y)$ integer quotient $\rightarrow C(Q)$
integer remainder $\rightarrow C(A)$

MODIFICATIONS: All

INDICATORS: (Indicators not listed are not affected)

	<u>If division takes place:</u>	<u>If no division takes place:</u>
Zero	If $C(Q) = 0$, then ON; otherwise OFF	If divisor = 0, then ON; otherwise OFF
Negative	If $C(Q)_0 = 1$, then ON; otherwise OFF	If dividend < 0, then ON; otherwise OFF

NOTES: A 36-bit integer dividend (including sign) is divided by a 36-bit integer divisor (including sign) to form a 36-bit integer quotient (including sign) and a 36-bit integer remainder (including sign). The remainder sign is equal to the dividend sign unless the remainder is zero.

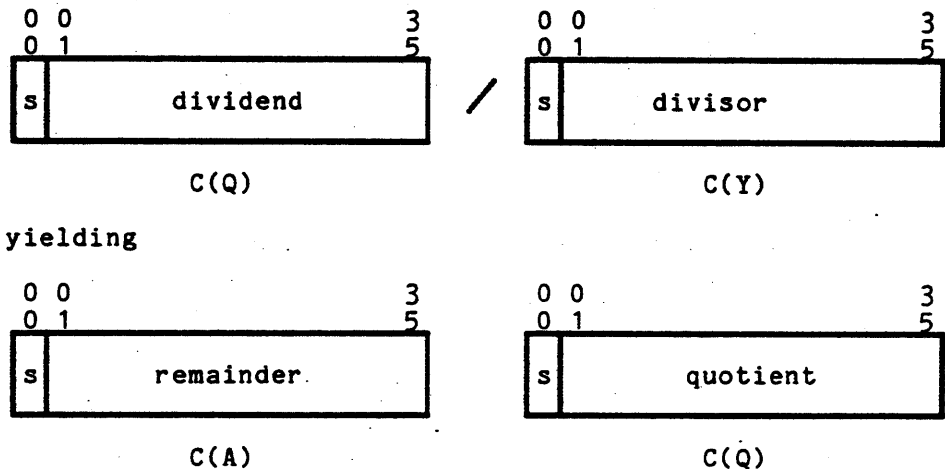

If the dividend = -2^{35} and the divisor = -1 or if the divisor = 0, then division does not take place. Instead, a divide check fault occurs, C(Q) contains the dividend magnitude, and the negative indicator reflects the dividend sign.

dvf	Divide Fraction	507 (0)
-----	-----------------	---------

FORMAT: Basic instruction format (see Figure 4-1).

SUMMARY: $C(AQ) / (Y)$ fractional quotient $\rightarrow C(A)$
 fractional remainder $\rightarrow C(Q)$

MODIFICATIONS: All

INDICATORS: (Indicators not listed are not affected)

	<u>If division takes place:</u>	<u>If no division takes place:</u>
Zero	If $C(A) = 0$, then ON; otherwise OFF	If divisor = 0, then ON; otherwise OFF
Negative	If $C(A)_0 = 1$, then ON; otherwise OFF	If dividend < 0, then ON; otherwise OFF

NOTES: A 71-bit fractional dividend (including sign) is divided by a 36-bit fractional divisor yielding a 36-bit fractional quotient (including sign) and a 36-bit fractional remainder (including sign). $C(AQ)_{71}$ is ignored; bit position 35 of the remainder corresponds to bit position 70 of the dividend. The remainder sign is equal to the dividend sign unless the remainder is zero.

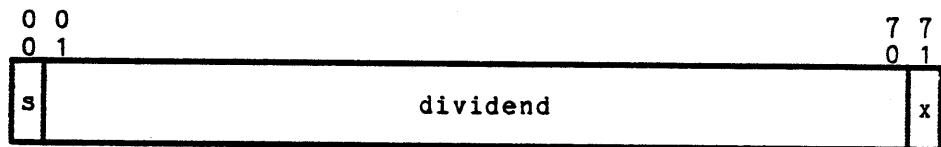

$C(AQ)$

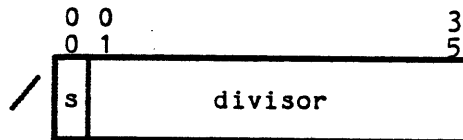

$C(Y)$

yielding

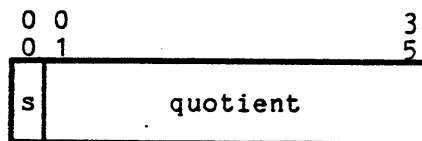

$C(A)$

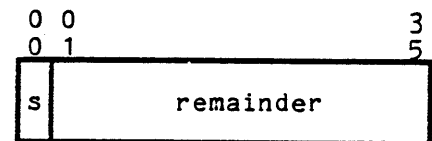

$C(Q)$

If $|\text{dividend}| \geq |\text{divisor}|$ or if the divisor = 0, division does not take place. Instead, a divide check fault occurs, C(AQ) contains the dividend magnitude in absolute, and the negative indicator reflects the dividend sign.

FIXED-POINT NEGATE

Fixed-Point Negate

neg	Negate A	531 (0)
-----	----------	---------

FORMAT: Basic instruction format (see Figure 4-1).

SUMMARY: $-C(A) \rightarrow C(A)$ if $C(A) \neq 0$

MODIFICATIONS: All, but none affect instruction execution.

INDICATORS: (Indicators not listed are not affected)

Zero If $C(A) = 0$, then ON; otherwise OFF

Negative If $C(A)_0 = 1$, then ON; otherwise OFF

Overflow If range of A is exceeded, then ON

NOTES: The neg instruction changes the number in A to its negative (if $\neq 0$). The operation is performed by forming the twos complement of the string of 36 bits.

Attempted repetition with the rpl instruction causes an illegal procedure fault.

negl	Negate Long	533 (0)
------	-------------	---------

FORMAT: Basic instruction format (see Figure 4-1).

SUMMARY: $-C(AQ) \rightarrow C(AQ)$ if $C(AQ) \neq 0$

MODIFICATIONS: All, but none affect instruction execution.

INDICATORS: (Indicators not listed are not affected)

Zero If $C(AQ) = 0$, then ON; otherwise OFF

Negative If $C(AQ)_0 = 1$, then ON; otherwise OFF

Overflow If range of AQ is exceeded, then ON

NOTES: The negl instruction changes the number in AQ to its negative (if $\neq 0$). The operation is performed by forming the twos complement of the string of 72 bits.

Attempted repetition with the rpl instruction causes an illegal procedure fault.

FIXED-POINT COMPARISON

Fixed-Point Comparison

cmg	Compare Magnitude	405 (0)
-----	-------------------	---------

FORMAT: Basic instruction format (see Figure 4-1).

SUMMARY: $|C(A)| :: |C(Y)|$

MODIFICATIONS: All

INDICATORS: (Indicators not listed are not affected)

Zero If $|C(A)| = |C(Y)|$, then ON; otherwise OFF

Negative If $|C(A)| < |C(Y)|$, then ON; otherwise OFF

cmk	Compare Masked	211 (0)
-----	----------------	---------

FORMAT: Basic instruction format (see Figure 4-1).

SUMMARY: For $i = 0, 1, \dots, 35$

$$C(Z)_i = \overline{C(Q)_i} \& [C(A)_i \oplus C(Y)_i]$$

MODIFICATIONS: All

INDICATORS: (Indicators not listed are not affected)

Zero If $C(Z) = 0$, then ON; otherwise OFF

Negative If $C(Z)_0 = 1$, then ON; otherwise OFF

NOTES: The cmk instruction compares the contents of bit positions of A and Y for identity that are not masked by a 1 in the corresponding bit position of Q.

The zero indicator is set ON if the comparison is successful for all bit positions; i.e., if for all $i = 0, 1, \dots, 35$ there is either: $C(A)_i = C(Y)_i$ (the identical case) or $C(Q)_i = 1$ (the masked case); otherwise, the zero indicator is set OFF.

The negative indicator is set ON if the comparison is unsuccessful for bit position 0; i.e., if $C(A)_0 \oplus C(Y)_0$

(they are nonidentical) as well as $C(Q)_0 = 0$ (they are unmasked); otherwise, the negative indicator is set OFF.

cmpa	Compare with A	115 (0)
------	----------------	---------

FORMAT: Basic instruction format (see Figure 4-1).

SUMMARY: $C(A) :: C(Y)$

MODIFICATIONS: All

INDICATORS: (Indicators not listed are not affected)

The zero (Z), negative (N), and carry (C) indicators are set as follows:

Algebraic Comparison (Signed Binary Operands)

<u>Z</u>	<u>N</u>	<u>C</u>	<u>Relation</u>	<u>Sign</u>
0	0	0	$C(A) > C(Y)$	$C(A)_0 = 0, C(Y)_0 = 1$
0	0	1	$C(A) > C(Y)$	} $C(A)_0 = C(Y)_0$
1	0	1	$C(A) = C(Y)$	
0	1	0	$C(A) < C(Y)$	
0	1	1	$C(A) < C(Y)$	$C(A)_0 = 1, C(Y)_0 = 0$

Logical Comparison (Unsigned Positive Binary Operands)

<u>Z</u>	<u>C</u>	<u>Relation</u>
0	0	$C(A) < C(Y)$
1	1	$C(A) = C(Y)$
0	1	$C(A) > C(Y)$

cmpaq	Compare with AQ	117 (0)
-------	-----------------	---------

FORMAT: Basic instruction format (see Figure 4-1).

SUMMARY: $C(AQ) :: C(Y\text{-pair})$

MODIFICATIONS: All except du, dl, ci, sc, scr

FIXED-POINT COMPARISON

INDICATORS: (Indicators not listed are not affected)

The zero (Z), negative (N), and carry (C) indicators are set as follows:

Algebraic Comparison (Signed Binary Operands)

<u>Z</u>	<u>N</u>	<u>C</u>	<u>Relation</u>	<u>Sign</u>
0	0	0	$C(AQ) > C(Y\text{-pair})$	$C(AQ)_0 = 0, C(Y\text{-pair})_0 = 1$
0	0	1	$C(AQ) > C(Y\text{-pair})$	} $C(AQ)_0 = C(Y\text{-pair})_0$
1	0	1	$C(AQ) = C(Y\text{-pair})$	
0	1	0	$C(AQ) < C(Y\text{-pair})$	
0	1	1	$C(AQ) < C(Y\text{-pair})$	$C(AQ)_0 = 1, C(Y\text{-pair})_0 = 0$

Logical Comparison (Unsigned Positive Binary Operands)

<u>Z</u>	<u>C</u>	<u>Relation</u>
0	0	$C(AQ) < C(Y\text{-pair})$
1	1	$C(AQ) = C(Y\text{-pair})$
0	1	$C(AQ) > C(Y\text{-pair})$

cmpq	Compare with Q	116 (0)
------	----------------	---------

FORMAT: Basic instruction format (see Figure 4-1).

SUMMARY: $C(Q) :: C(Y)$

MODIFICATIONS: All

INDICATORS: (Indicators not listed are not affected)

The zero (Z), negative (N), and carry (C) indicators are set as follows:

Algebraic Comparison (Signed Binary Operands)

<u>Z</u>	<u>N</u>	<u>C</u>	<u>Relation</u>	<u>Sign</u>
0	0	0	$C(Q) > C(Y)$	$C(Q)_0 = 0, C(Y)_0 = 1$
0	0	1	$C(Q) > C(Y)$	} $C(Q)_0 = C(Y)_0$
1	0	1	$C(Q) = C(Y)$	
0	1	0	$C(Q) < C(Y)$	
0	1	1	$C(Q) < C(Y)$	$C(Q)_0 = 1, C(Y)_0 = 0$

Logical Comparison (Unsigned Positive Binary Operands)

<u>Z</u>	<u>C</u>	<u>Relation</u>
0	0	$C(Q) < C(Y)$
1	1	$C(Q) = C(Y)$
0	1	$C(Q) > C(Y)$

<u>cmpxn</u>	Compare with Index Register <u>n</u>	10 <u>n</u> (0)
--------------	--------------------------------------	-----------------

FORMAT: Basic instruction format (see Figure 4-1).

SUMMARY: For $n = 0, 1, \dots, \text{or } 7$ as determined by operation code
 $C(Xn) :: C(Y)_{0,17}$

MODIFICATIONS: All except *ci*, *sc*, *scr*

INDICATORS: (Indicators not listed are not affected)

The zero (Z), negative (N), and carry (C) indicators are set as follows:

Algebraic Comparison (Signed Binary Operands)

<u>Z</u>	<u>N</u>	<u>C</u>	<u>Relation</u>	<u>Sign</u>
0	0	0	$C(Xn) > C(Y)_{0,17}$	$C(Xn)_0 = 0, C(Y)_0 = 1$
0	0	1	$C(Xn) > C(Y)_{0,17}$	} $C(Xn)_0 = C(Y)_0$
1	0	1	$C(Xn) = C(Y)_{0,17}$	
0	1	0	$C(Xn) < C(Y)_{0,17}$	
0	1	1	$C(Xn) < C(Y)_{0,17}$	$C(Xn)_0 = 1, C(Y)_0 = 0$

Logical Comparison (Unsigned Positive Binary Operands)

<u>Z</u>	<u>C</u>	<u>Relation</u>
0	0	$C(X_n) < C(Y)_{0,17}$
1	1	$C(X_n) = C(Y)_{0,17}$
0	1	$C(X_n) > C(Y)_{0,17}$

cwl	Compare with Limits	111 (0)
-----	---------------------	---------

FORMAT: Basic instruction format (see Figure 4-1).

SUMMARY: $C(Y) ::$ closed interval $[C(A);C(Q)]$
 $C(Y) :: C(Q)$

MODIFICATIONS: All

INDICATORS: (Indicators not listed are not affected)

Zero If $C(A) \leq C(Y) \leq C(Q)$ or $C(A) \geq C(Y) \geq C(Q)$, then ON; otherwise OFF.

The negative (N) and carry (C) indicators are set as follows:

<u>N</u>	<u>C</u>	<u>Relation</u>	<u>Sign</u>
0	0	$C(Q) > C(Y)$	$C(Q)_0 = 0, C(Y)_0 = 1$
0	1	$C(Q) \geq C(Y)$	} $C(Q)_0 = C(Y)_0$
1	0	$C(Q) < C(Y)$	
1	1	$C(Q) < C(Y)$	$C(Q)_0 = 1, C(Y)_0 = 0$

NOTES: The cwl instruction tests the value of C(Y) to determine if it is within the range of values set by C(A) and C(Q). The comparison of C(Y) with C(Q) locates C(Y) with respect to the interval if C(Y) is not contained within the interval.

Fixed-Point Miscellaneous

szn	Set Zero and Negative Indicators	234 (0)
-----	----------------------------------	---------

FORMAT: Basic instruction format (see Figure 4-1).

SUMMARY: Set indicators according to C(Y)

MODIFICATIONS: All

INDICATORS: (Indicators not listed are not affected)

Zero If $C(Y) = 0$, then ON; otherwise OFF

Negative If $C(Y)_0 = 1$, then ON; otherwise OFF

sznc	Set Zero and Negative Indicators and Clear	214 (0)
------	--	---------

FORMAT: Basic instruction format (see Figure 4-1).

SUMMARY: Set indicators according to C(Y)

00...0 => C(Y)

MODIFICATIONS: All except du, dl, ci, sc, scr

INDICATORS: (Indicators not listed are not affected)

Zero If $C(Y) = 0$, then ON, otherwise OFF

Negative If $C(Y)_0 = 1$, then ON; otherwise OFF

BOOLEAN OPERATION INSTRUCTIONS

Boolean AND

ana	AND to A	375 (0)
-----	----------	---------

FORMAT: Basic instruction format (see Figure 4-1).

SUMMARY: $C(A)_i \& C(Y)_i \rightarrow C(A)_i$ for $i = (0, 1, \dots, 35)$

MODIFICATIONS: All

INDICATORS: (Indicators not listed are not affected)

Zero If $C(A) = 0$, then ON; otherwise OFF

Negative If $C(A)_0 = 1$, then ON; otherwise OFF

anaq	AND to AQ	377 (0)
------	-----------	---------

FORMAT: Basic instruction format (see Figure 4-1).

SUMMARY: $C(AQ)_i \& C(Y\text{-pair})_i \rightarrow C(AQ)_i$ for $i = (0, 1, \dots, 71)$

MODIFICATIONS: All except du, dl, ci, sc, scr

INDICATORS: (Indicators not listed are not affected)

Zero If $C(AQ) = 0$, then ON; otherwise OFF

Negative If $C(AQ)_0 = 1$, then ON; otherwise OFF

anq	AND to Q	376 (0)
-----	----------	---------

FORMAT: Basic instruction format (see Figure 4-1).

SUMMARY: $C(Q)_i \& C(Y)_i \rightarrow C(Q)_i$ for $i = (0, 1, \dots, 35)$

MODIFICATIONS: All

INDICATORS: (Indicators not listed are not affected)

Zero If $C(Q) = 0$, then ON; otherwise OFF

Negative If $C(Q)_0 = 1$, then ON; otherwise OFF

ansa	AND to Storage A	355 (0)
------	------------------	---------

FORMAT: Basic instruction format (see Figure 4-1).

SUMMARY: $C(A)_i \& C(Y)_i \rightarrow C(Y)_i$ for $i = (0, 1, \dots, 35)$

MODIFICATIONS: All except du, dl, ci, sc, scr

INDICATORS: (Indicators not listed are not affected)

Zero If $C(Y) = 0$, then ON; otherwise OFF

Negative If $C(Y)_0 = 1$, then ON; otherwise OFF

NOTES: Attempted repetition with the rpl instruction causes an illegal procedure fault.

ansq	AND to Storage Q	356 (0)
------	------------------	---------

FORMAT: Basic instruction format (see Figure 4-1).
SUMMARY: $C(Q)_i \& C(Y)_i \rightarrow C(Y)_i$ for $i = (0, 1, \dots, 35)$
MODIFICATIONS: All except du, dl, ci, sc, scr
INDICATORS: (Indicators not listed are not affected)
 Zero If $C(Y) = 0$, then ON; otherwise OFF
 Negative If $C(Y)_0 = 1$, then ON; otherwise OFF
NOTES: Attempted repetition with the rpl instruction causes an illegal procedure fault.

ansxn	AND to Storage Index Register <u>n</u>	34 <u>n</u> (0)
-------	--	-----------------

FORMAT: Basic instruction format (see Figure 4-1).
SUMMARY: For $n = 0, 1, \dots, \text{or } 7$ as determined by operation code
 $C(Xn)_i \& C(Y)_i \rightarrow C(Y)_i$ for $i = (0, 1, \dots, 17)$
MODIFICATIONS: All except du, dl, ci, sc, scr
INDICATORS: (Indicators not listed are not affected)
 Zero If $C(Y)_{0,17} = 0$, then ON; otherwise OFF
 Negative If $C(Y)_0 = 1$, then ON; otherwise OFF
NOTES: Attempted repetition with the rpl instruction causes an illegal procedure fault.

<u>anxn</u>	AND to Index Register <u>n</u>	36 <u>n</u> (0)
-------------	--------------------------------	-----------------

FORMAT: Basic instruction format (see Figure 4-1).

SUMMARY: For $n = 0, 1, \dots, \text{or } 7$ as determined by operation code
 $C(Xn)_i \ \& \ C(Y)_i \rightarrow C(Xn)_i$ for $i = (0, 1, \dots, 17)$

MODIFICATIONS: All except ci, sc, scr

INDICATORS: (Indicators not listed are not affected)

Zero If $C(Xn) = 0$, then ON; otherwise OFF

Negative If $C(Xn)_0 = 1$, then ON; otherwise OFF

BOOLEAN OR

Boolean Or

ora	OR to A	275 (0)
-----	---------	---------

FORMAT: Basic instruction format (see Figure 4-1).

SUMMARY: $C(A)_i \mid C(Y)_i \rightarrow C(A)_i$ for $i = (0, 1, \dots, 35)$

MODIFICATIONS: All

INDICATORS: (Indicators not listed are not affected)

Zero If $C(A) = 0$, then ON; otherwise OFF

Negative If $C(A)_0 = 1$, then ON; otherwise OFF

oraq	OR to AQ	277 (0)
------	----------	---------

FORMAT: Basic instruction format (see Figure 4-1).

SUMMARY: $C(AQ)_i \mid C(Y\text{-pair})_i \rightarrow C(AQ)_i$ for $i = (0, 1, \dots, 71)$

MODIFICATIONS: All except du, dl, ci, sc, scr

INDICATORS: (Indicators not listed are not affected)

Zero If $C(AQ) = 0$, then ON; otherwise OFF

Negative If $C(AQ)_0 = 1$, then ON; otherwise OFF

orq	OR to Q	276 (0)
-----	---------	---------

FORMAT: Basic instruction format (see Figure 4-1).

SUMMARY: $C(Q)_i \mid C(Y)_i \rightarrow C(Q)_i$ for $i = (0, 1, \dots, 35)$

MODIFICATIONS: All

INDICATORS: (Indicators not listed are not affected)

Zero If $C(Q) = 0$, then ON; otherwise OFF

Negative If $C(Q)_0 = 1$, then ON; otherwise OFF

orsa	OR to Storage A	255 (0)
------	-----------------	---------

FORMAT: Basic instruction format (see Figure 4-1).

SUMMARY: $C(A)_i \mid C(Y)_i \rightarrow C(Y)_i$ for $i = (0, 1, \dots, 35)$

MODIFICATIONS: All except du, dl, ci, sc, scr

INDICATORS: (Indicators not listed are not affected)

Zero If $C(Y) = 0$, then ON; otherwise OFF

Negative If $C(Y)_0 = 1$, then ON; otherwise OFF

NOTES: Attempted repetition with the rpl instruction causes an illegal procedure fault.

orsq	OR to Storage Q	256 (0)
------	-----------------	---------

FORMAT: Basic instruction format (see Figure 4-1).

SUMMARY: $C(Q)_i \mid C(Y)_i \rightarrow C(Y)_i$ for $i = (0, 1, \dots, 35)$

MODIFICATIONS: All except du, dl, ci, sc, scr

INDICATORS: (Indicators not listed are not affected)

Zero If $C(Y) = 0$, then ON; otherwise OFF

Negative If $C(Y)_0 = 1$, then ON; otherwise OFF

NOTES: Attempted repetition with the rpl instruction causes an illegal procedure fault.

orsxn	OR to Storage Index Register <u>n</u>	24 <u>n</u> (0)
-------	---------------------------------------	-----------------

FORMAT: Basic instruction format (see Figure 4-1).

SUMMARY: For $n = 0, 1, \dots, \text{or } 7$ as determined by operation code
 $C(Xn)_i \mid C(Y)_i \rightarrow C(Y)_i$ for $i = (0, 1, \dots, 17)$

MODIFICATIONS: All except du, dl, ci, sc, scr

INDICATORS: (Indicators not listed are not affected)

Zero If $C(Y)_{0,17} = 0$, then ON; otherwise OFF

Negative If $C(Y)_0 = 1$, then ON; otherwise OFF

NOTES: Attempted repetition with the rpl instruction causes an illegal procedure fault.

<u>orxn</u>	OR to Index Register <u>n</u>	<u>26n</u> (0)
-------------	-------------------------------	----------------

FORMAT: Basic instruction format (see Figure 4-1).

SUMMARY: For $n = 0, 1, \dots, \text{or } 7$ as determined by operation code
 $C(Xn)_i \mid C(Y)_i \rightarrow C(Xn)_i$ for $i = (0, 1, \dots, 17)$

MODIFICATIONS: All except ci, sc, scr

INDICATORS: (Indicators not listed are not affected)

Zero If $C(Xn) = 0$, then ON; otherwise OFF

Negative If $C(Xn)_0 = 1$, then ON; otherwise OFF

BOOLEAN EXCLUSIVE OR

Boolean Exclusive Or

era	EXCLUSIVE OR to A	675 (0)
-----	-------------------	---------

FORMAT: Basic instruction format (see Figure 4-1).

SUMMARY: $C(A)_i \oplus C(Y)_i \rightarrow C(A)_i$ for $i = (0, 1, \dots, 35)$

MODIFICATIONS: All

INDICATORS: (Indicators not listed are not affected)

Zero If $C(A) = 0$, then ON; otherwise OFF

Negative If $C(A)_0 = 1$, then ON; otherwise OFF

eraq	EXCLUSIVE OR to AQ	677 (0)
------	--------------------	---------

FORMAT: Basic instruction format (see Figure 4-1).

SUMMARY: $C(AQ)_i \oplus C(Y\text{-pair})_i \rightarrow C(AQ)_i$ for $i = (0, 1, \dots, 71)$

MODIFICATIONS: All except du, dl, ci, sc, scr

INDICATORS: (Indicators not listed are not affected)

Zero If $C(AQ) = 0$, then ON; otherwise OFF

Negative If $C(AQ)_0 = 1$, then ON; otherwise OFF

erq	EXCLUSIVE OR to Q	676 (0)
-----	-------------------	---------

FORMAT: Basic instruction format (see Figure 4-1).

SUMMARY: $C(Q)_i \oplus C(Y)_i \rightarrow C(Q)_i$ for $i = (0, 1, \dots, 35)$

MODIFICATIONS: All

INDICATORS: (Indicators not listed are not affected)

Zero If $C(Q) = 0$, then ON; otherwise OFF

Negative If $C(Q)_0 = 1$, then ON; otherwise OFF

ersa	EXCLUSIVE OR to Storage A	655 (0)
------	---------------------------	---------

FORMAT: Basic instruction format (see Figure 4-1).

SUMMARY: $C(A)_i \oplus C(Y)_i \rightarrow C(Y)_i$ for $i = (0, 1, \dots, 35)$

MODIFICATIONS: All except du, dl, ci, sc, scr

INDICATORS: (Indicators not listed are not affected)

Zero If $C(Y) = 0$, then ON; otherwise OFF

Negative If $C(Y)_0 = 1$, then ON; otherwise OFF

NOTES: Attempted repetition with the rpl instruction causes an illegal procedure fault.

BOOLEAN EXCLUSIVE OR

ersq	EXCLUSIVE OR to Storage Q	656 (0)
------	---------------------------	---------

FORMAT: Basic instruction format (see Figure 4-1).

SUMMARY: $C(Q)_i \oplus C(Y)_i \rightarrow C(Y)_i$ for $i = (0, 1, \dots, 35)$

MODIFICATIONS: All except du, dl, ci, sc, scr

INDICATORS: (Indicators not listed are not affected)

Zero If $C(Y) = 0$, then ON; otherwise OFF

Negative If $C(Y)_0 = 1$, then ON; otherwise OFF

NOTES: Attempted repetition with the rpl instruction causes an illegal procedure fault.

ersxn	EXCLUSIVE OR to Storage Index Register <u>n</u>	64 <u>n</u> (0)
-------	---	-----------------

FORMAT: Basic instruction format (see Figure 4-1).

SUMMARY: For $n = 0, 1, \dots, \text{or } 7$ as determined by operation code

$C(Xn)_i \oplus C(Y)_i \rightarrow C(Y)_i$ for $i = (0, 1, \dots, 17)$

MODIFICATIONS: All except du, dl, ci, sc, scr

INDICATORS: (Indicators not listed are not affected)

Zero If $C(Y)_{0,17} = 0$, then ON; otherwise OFF

Negative If $C(Y)_0 = 0$, then ON; otherwise OFF

NOTES: Attempted repetition with the rpl instruction causes an illegal procedure fault.

erxn	EXCLUSIVE OR to Index Register <u>n</u>	66n (0)
------	---	---------

FORMAT: Basic instruction format (see Figure 4-1).

SUMMARY: For $n = 0, 1, \dots, \text{or } 7$ as determined by operation code
 $C(Xn)_i \oplus C(Y)_i \rightarrow C(Xn)_i$ for $i = (0, 1, \dots, 17)$

MODIFICATIONS: All except ci, sc, scr

INDICATORS: (Indicators not listed are not affected)

Zero If $C(Xn) = 0$, then ON; otherwise OFF

Negative If $C(Xn)_0 = 1$, then ON; otherwise OFF

BOOLEAN COMPARATIVE AND

Boolean Comparative And

cana	Comparative AND with A	315 (0)
------	------------------------	---------

FORMAT: Basic instruction format (see Figure 4-1).

SUMMARY: $C(Z)_i = C(A)_i \& C(Y)_i$ for $i = (0, 1, \dots, 35)$

MODIFICATIONS: All

INDICATORS: (Indicators not listed are not affected)

ZERO If $C(Z) = 0$, then ON; otherwise OFF

Negative If $C(Z)_0 = 1$, then ON; otherwise OFF

canaq	Comparative AND with AQ	317 (0)
-------	-------------------------	---------

FORMAT: Basic instruction format (see Figure 4-1).

SUMMARY: $C(Z)_i = C(AQ)_i \& C(Y\text{-pair})_i$ for $i = (0, 1, \dots, 71)$

MODIFICATIONS: All except du, dl, ci, sc, scr

INDICATORS: (Indicators not listed are not affected)

Zero If $C(Z) = 0$, then ON; otherwise OFF

Negative If $C(Z)_0S = 1$, then ON; otherwise OFF

canq	Comparative AND with Q	316 (0)
------	------------------------	---------

FORMAT: Basic instruction format (see Figure 4-1).

SUMMARY: $C(Z)_i = C(Q)_i \& C(Y)_i$ for $i = (0, 1, \dots, 35)$

MODIFICATIONS: All

INDICATORS: (Indicators not listed are not affected)

ZERO If $C(Z) = 0$, then ON; otherwise OFF

Negative If $C(Z)_0 = 1$, then ON; otherwise OFF

canxn	Comparative AND with Index Register <u>n</u>	30 <u>n</u> (0)
-------	--	-----------------

FORMAT: Basic instruction format (see Figure 4-1).

SUMMARY: For $n = 0, 1, \dots, \text{or } 7$ as determined by operation code
 $C(Z)_i = C(Xn)_i \& C(Y)_i$ for $i = (0, 1, \dots, 17)$

MODIFICATIONS: All except ci, sc, scr

INDICATORS: (Indicators not listed are not affected)

Zero If $C(Z) = 0$, then ON; otherwise OFF

Negative If $C(Z)_0 = 1$, then ON; otherwise OFF

BOOLEAN COMPARATIVE NOT

Boolean Comparative Not

cnaa	Comparative NOT with A	215 (0)
------	------------------------	---------

FORMAT: Basic instruction format (see Figure 4-1).

SUMMARY: $C(Z)_i = C(A)_i \& \overline{C(Y)}_i$ for $i = (0, 1, \dots, 35)$

MODIFICATIONS: All

INDICATORS: (Indicators not listed are not affected)

Zero If $C(Z) = 0$, then ON; otherwise OFF

Negative If $C(Z)_0 = 1$, then ON; otherwise OFF

cnaaq	Comparative NOT with AQ	217 (0)
-------	-------------------------	---------

FORMAT: Basic instruction format (see Figure 4-1).

SUMMARY: $C(Z)_i = C(AQ)_i \& \overline{C(Y\text{-pair})}_i$ for $i = (0, 1, \dots, 71)$

MODIFICATIONS: All except du, dl, ci, sc, scr

INDICATORS: (Indicators not listed are not affected)

Zero If $C(Z) = 0$, then ON; otherwise OFF

Negative If $C(Z)_0 = 1$, then ON; otherwise OFF

cnaq	Comparative NOT with Q	216 (0)
------	------------------------	---------

FORMAT: Basic instruction format (see Figure 4-1).

SUMMARY: $C(Z)_i = C(Q)_i \& \overline{C(Y)}_i$ for $i = (0, 1, \dots, 35)$

MODIFICATIONS: All

INDICATORS: (Indicators not listed are not affected)

BOOLEAN COMPARATIVE NOT

Zero If $C(Z) = 0$, then ON; otherwise OFF
 Negative If $C(Z)_0 = 1$, then ON; otherwise OFF

<u>cnaxn</u>	Comparative NOT with Index Register <u>n</u>	20 <u>n</u> (0)
--------------	--	-----------------

FORMAT: Basic instruction format (see Figure 4-1).

SUMMARY: For $n = 0, 1, \dots, \text{ or } 7$ as determined by operation code
 $C(Z)_i = C(Xn)_i \ \& \ \overline{C(Y)}_i$ for $i = (0, 1, \dots, 17)$

MODIFICATIONS: All except ci, sc, scr

INDICATORS: (Indicators not listed are not affected)

Zero If $C(Z) = 0$, then ON; otherwise OFF
 Negative If $C(Z)_0 = 1$, then ON; otherwise OFF

FLOATING-POINT DATA MOVEMENT LOAD

FLOATING-POINT ARITHMETIC INSTRUCTIONS

Floating-Point Data Movement Load

dfld	Double-Precision Floating Load	433 (0)
------	--------------------------------	---------

FORMAT: Basic instruction format (see Figure 4-1).

SUMMARY: C(Y-pair)_{0,7} -> C(E)
 C(Y-pair)_{8,71} -> C(AQ)_{0,63}
 00...0 -> C(AQ)_{64,71}

MODIFICATIONS: All except du, dl, ci, sc, scr

INDICATORS: (Indicators not listed are not affected)

Zero If C(AQ) = 0, then ON; otherwise OFF

Negative If C(AQ)₀ = 1, then ON; otherwise OFF

fld	Floating Load	431 (0)
-----	---------------	---------

FORMAT: Basic instruction format (see Figure 4-1).

SUMMARY: C(Y)_{0,7} -> C(E)
 C(Y)_{8,35} -> C(AQ)_{0,27}
 00...0 -> C(AQ)_{30,71}

MODIFICATIONS: All except ci, sc, scr

INDICATORS: (Indicators not listed are not affected)

Zero If C(AQ) = 0, then ON; otherwise OFF

Negative IF C(AQ)₀ = 1, then ON; otherwise OFF

Floating-Point Data Movement Store

dfst	Double-Precision Floating Store	457 (0)
------	---------------------------------	---------

FORMAT: Basic instruction format (see Figure 4-1).

SUMMARY: C(E) → C(Y-pair)_{0,7}
 C(AQ)_{0,63} → C(Y-pair)_{8,71}

MODIFICATIONS: All except du, dl, ci, sc, scr

INDICATORS: None affected

NOTES: Attempted repetition with the rpl instruction causes an illegal procedure fault.

dfstr	Double-Precision Floating Store Rounded	472 (0)
-------	---	---------

FORMAT: Basic instruction format (see Figure 4-1).

SUMMARY: C(EAQ) rounded → C(Y-pair) (as in dfst)

MODIFICATIONS: All except du, dl, ci, sc, scr

INDICATORS: (Indicators not listed are not affected)

Zero If C(Y-pair) = floating point 0, then ON; otherwise OFF

Negative If C(Y-pair)₈ = 1, then ON; otherwise OFF

Exponent Overflow If exponent is greater than +127, then ON

Exponent Underflow If exponent is less than -128, then ON

NOTES: The dfstr instruction performs a double-precision true round and normalization on C(EAQ) as it is stored.

The definition of true round is located under the description of the frd instruction.

The definition of normalization is located under the description of the fno instruction.

FLOATING-POINT DATA MOVEMENT STORE

Except for the precision of the stored result, the dfstr instruction is identical to the fstr instruction.

Attempted repetition with the rpl instruction causes an illegal procedure fault.

fst	Floating Store	455 (0)
-----	----------------	---------

FORMAT: Basic instruction format (see Figure 4-1).

SUMMARY: C(E) → C(Y)_{0,7}
C(A)_{0,27} → C(Y)_{8,35}

MODIFICATIONS: All except du, dl, ci, sc, scr

INDICATORS: None affected

NOTES: Attempted repetition with the rpl instruction causes an illegal procedure fault.

fstr	Floating Store Rounded	470 (0)
------	------------------------	---------

FORMAT: Basic instruction format (see Figure 4-1).

SUMMARY: C(EAQ) rounded → C(Y) (as in fst)

MODIFICATIONS: All except du, dl, ci, sc, scr

INDICATORS: (Indicators not listed are not affected)

Zero If C(Y) = floating point 0, then ON; otherwise OFF

Negative If C(Y)₈ = 1, then ON; otherwise OFF

Exponent Overflow If exponent is greater than +127, then ON

Exponent Underflow If exponent is less than -128, then ON

NOTES: The fstr instruction performs a true round and normalization on C(EAQ) as it is stored.

The definition of true round is located under the description of the frd instruction.

The definition of normalization is located under the description of the fno instruction.

Attempted repetition with the rpl instruction causes an illegal procedure fault.

FLOATING-POINT ADDITION

Floating-Point Addition

dfad	Double-Precision Floating Add	477 (0)
------	-------------------------------	---------

FORMAT: Basic instruction format (see Figure 4-1).

SUMMARY: $[C(EAQ) + C(Y\text{-pair})]$ normalized $\rightarrow C(EAQ)$

MODIFICATIONS: All except du, dl, ci, sc, scr

INDICATORS: (Indicators not listed are not affected)

Zero If $C(AQ) = 0$, then ON; otherwise OFF

Negative If $C(AQ)_0 = 1$, then ON; otherwise OFF

Exponent Overflow If exponent is greater than +127, then ON

Exponent Underflow If exponent is less than -128, then ON

Carry If a carry out of AQ_0 is generated, then ON; otherwise OFF

NOTES: The dfad instruction may be thought of as a dufa instruction followed by a fno instruction.

The definition of normalization is located under the description of the fno instruction.

dufa	Double-Precision Unnormalized Floating Add	437 (0)
------	--	---------

FORMAT: Basic instruction format (see Figure 4-1).

SUMMARY: $C(EAQ) + C(Y\text{-pair}) \rightarrow C(EAQ)$

MODIFICATIONS: All except du, dl, ci, sc, scr

INDICATORS: (Indicators not listed are not affected)

Zero If $C(AQ) = 0$, then ON; otherwise OFF

Negative If $C(AQ)_0 = 1$, then ON; otherwise OFF

Exponent Overflow If exponent is greater than +127, then ON

Exponent Underflow If exponent is less than -128, then ON

Carry If a carry out of AQ₀ is generated, then ON; otherwise OFF

NOTES: Except for the precision of the mantissa of the operand from main memory, the dufa instruction is identical to the ufa instruction.

fad	Floating Add	475 (0)
-----	--------------	---------

FORMAT: Basic instruction format (see Figure 4-1).

SUMMARY: $[C(EAQ) + C(Y)]$ normalized $\rightarrow C(EAQ)$

MODIFICATIONS: All except ci, sc, scr

INDICATORS: (Indicators not listed are not affected)

Zero If C(AQ) = 0, then ON; otherwise OFF

Negative If C(AQ)₀ = 1, then ON; otherwise OFF

Exponent Overflow If exponent is greater than +127, then ON

Exponent Underflow If exponent is less than -128, then ON

Carry If a carry out of AQ₀ is generated, then ON; otherwise OFF

NOTES: The fad instruction may be thought of a an ufa instruction followed by a fno instruction.

The definition of normalization is located under the description of the fno instruction.

ufa	Unnormalized Floating Add	435 (0)
-----	---------------------------	---------

FORMAT: Basic instruction format (see Figure 4-1).

SUMMARY: C(EAQ) + C(Y) \rightarrow C(EAQ)

MODIFICATIONS: All except ci, sc, scr

FLOATING-POINT ADDITION

INDICATORS:	(Indicators not listed are not affected)
Zero	If $C(AQ) = 0$, then ON; otherwise OFF
Negative	If $C(AQ)_0 = 1$, then ON; otherwise OFF
Exponent Overflow	If exponent is greater than +127, then ON
Exponent Underflow	If exponent is less than -128, then ON
Carry	If a carry out of AQ_0 is generated, then ON; otherwise OFF

NOTES: The ufa instruction is executed as follows:

The mantissas are aligned by shifting the mantissa of the operand having the algebraically smaller exponent to the right the number of places equal to the absolute value of the difference in the two exponents. Bits shifted beyond the bit position equivalent to AQ_{71} are lost.

The algebraically larger exponent replaces $C(E)$.

The sum of the mantissas replaces $C(AQ)$.

If an overflow occurs during addition, then;

$C(AQ)$ are shifted one place to the right.

$C(AQ)_0$ is inverted to restore the sign.

$C(E)$ is increased by one.

Floating-Point Subtraction

dfsb	Double-Precision Floating Subtract	577 (0)
------	------------------------------------	---------

FORMAT: Basic instruction format (see Figure 4-1).

SUMMARY: $[C(EAQ) - C(Y\text{-pair})]$ normalized $\rightarrow C(EAQ)$

MODIFICATIONS: All except du, dl, ci, sc, scr

INDICATORS: (Indicators not listed are not affected)

Zero If $C(AQ) = 0$, then ON; otherwise OFF

Negative If $C(AQ)_0 = 1$, then ON; otherwise OFF

Exponent
Overflow If exponent is greater than +127, then ON

Exponent
Underflow If exponent is less than -128, then ON

Carry If a carry out of AQ_0 is generated, then ON; otherwise OFF

NOTES: The dfsb instruction is identical to the dfad instruction with the exception that the two's complement of the mantissa of the operand from main memory is used.

dufs	Double-Precision Unnormalized Floating Subtract	537 (0)
------	---	---------

FORMAT: Basic instruction format (see Figure 4-1).

SUMMARY: $C(EAQ) - C(Y\text{-pair}) \rightarrow C(EAQ)$

MODIFICATIONS: All except du, dl, ci, sc, scr

INDICATORS: (Indicators not listed are not affected)

Zero If $C(AQ) = 0$, then ON; otherwise OFF

Negative If $C(AQ)_0 = 1$, then ON; otherwise OFF

Exponent
Overflow If exponent is greater than +127, then ON

FLOATING-POINT SUBTRACTION

Exponent Underflow If exponent is less than -128, then ON

Carry If a carry out of AQ_0 is generated, then ON; otherwise OFF

NOTES: Except for the precision of the mantissa of the operand from main memory, the dufs instruction is identical with the ufs instruction.

fsb	Floating Subtract	575 (0)
-----	-------------------	---------

FORMAT: Basic instruction format (see Figure 4-1).

SUMMARY: $[C(EAQ) - C(Y)]$ normalized $\rightarrow C(EAQ)$

MODIFICATIONS: All except ci, sc, scr

INDICATORS: (Indicators not listed are not affected)

Zero If $C(AQ) = 0$, then ON; otherwise OFF

Negative If $C(AQ)_0 = 1$, then ON; otherwise OFF

Exponent Overflow If exponent is greater than +127, then ON

Exponent Underflow If exponent is less than -128, then ON

Carry If a carry out of AQ_0 is generated, then ON; otherwise OFF

NOTES: The fsb instruction may be thought of as an ufs instruction followed by a fno instruction.

The definition of normalization is located under the description of the fno instruction.

ufs	Unnormalized Floating Subtract	535 (0)
-----	--------------------------------	---------

FORMAT: Basic instruction format (see Figure 4-1).

SUMMARY: $C(EAQ) - C(Y) \rightarrow C(EAQ)$

MODIFICATIONS: All except ci, sc, scr

INDICATORS: (Indicators not listed are not affected)

- Zero If $C(AQ) = 0$, then ON; otherwise OFF
- Negative If $C(AQ)_0 = 1$, then ON; otherwise OFF
- Exponent Overflow If exponent is greater than +127, then ON
- Exponent Underflow If exponent is less than -128, then ON
- Carry If a carry out of AQ_0 is generated, then ON; otherwise OFF

NOTES: The ufs instruction is identical to the ufa instruction with the exception that the twos complement of the mantissa of the operand from main memory is used.

FLOATING-POINT MULTIPLICATION

Floating-Point Multiplication

dfmp	Double-Precision Floating Multiply	463 (0)
------	------------------------------------	---------

FORMAT: Basic instruction format (see Figure 4-1).

SUMMARY: $[C(EAQ) \times C(Y\text{-pair})]$ normalized $\rightarrow C(EAQ)$

MODIFICATIONS: All except du, dl, ci, sc, scr

INDICATORS: (Indicators not listed are not affected)

Zero If $C(AQ) = 0$, then ON; otherwise OFF

Negative If $C(AQ)_0 = 1$, then ON; otherwise OFF

Exponent Overflow If exponent is greater than +127, then ON

Exponent Underflow If exponent is less than -128, then ON

NOTES: The dfmp instruction may be thought of as a dufm instruction followed by a fno instruction.

The definition of normalization is located under the description of the fno instruction.

dufm	Double-Precision Unnormalized Floating Multiply	423 (0)
------	---	---------

FORMAT: Basic instruction format (see Figure 4-1).

SUMMARY: $C(EAQ) \times C(Y\text{-pair}) \rightarrow C(EAQ)$

MODIFICATIONS: All except du, dl, ci, sc, scr

INDICATORS: (Indicators not listed are not affected)

Zero If $C(AQ) = 0$, then ON; otherwise OFF

Negative If $C(AQ)_0 = 1$, then ON; otherwise OFF

Exponent Overflow If exponent is greater than +127, then ON

Exponent Underflow If exponent is less than -128, then ON

NOTES: Except for the precision of the mantissa of the operand from main memory, the dufm instruction is identical to the ufm instruction.

fmp	Floating Multiply	461 (0)
-----	-------------------	---------

FORMAT: Basic instruction format (see Figure 4-1).

SUMMARY: $[C(EAQ) \times C(Y)]$ normalized $\rightarrow C(EAQ)$

MODIFICATIONS: All except ci, sc, scr

INDICATORS: (Indicators not listed are not affected)

- Zero If $C(AQ) = 0$, then ON; otherwise OFF
- Negative If $C(AQ)_0 = 1$, then ON; otherwise OFF
- Exponent Overflow If exponent is greater than +127, then ON
- Exponent Underflow If exponent is less than -128, then ON

NOTES: The fmp instruction may be thought of as a ufm instruction followed by a fno instruction.

The definition of normalization is located under the description of the fno instruction.

FLOATING-POINT MULTIPLICATION

ufm	Unnormalized Floating Multiply	421 (0)
-----	--------------------------------	---------

FORMAT: Basic instruction format (see Figure 4-1).

SUMMARY: $C(EAQ) \times C(Y) \rightarrow C(EAQ)$

MODIFICATIONS: All except ci, sc, scr

INDICATORS: (Indicators not listed are not affected)

- Zero If $C(AQ) = 0$, then ON; otherwise OFF
- Negative If $C(AQ)_0 = 1$, then ON; otherwise OFF
- Exponent Overflow If exponent is greater than +127, then ON
- Exponent Underflow If exponent is less than -128, then ON

NOTES: The ufm instruction is executed as follows:

$$C(E)_0 + C(Y)_{0,7} \rightarrow C(E)$$

$$\left[C(AQ) \times C(Y)_{8,35} \right]_{0,71} \rightarrow C(AQ)$$

A normalization is performed only in the case of both factor mantissas being 100...0 which is the twos complement approximation to the decimal value -1.0.

The definition of normalization is located under the description of the fno instruction.

Floating-Point Division

dfdi	Double-Precision Floating Divide Inverted	527 (0)
------	---	---------

FORMAT: Basic instruction format (see Figure 4-1).

SUMMARY: $C(Y\text{-pair}) / C(EAQ) \rightarrow C(EAQ)$

MODIFICATIONS: All except du, dl, ci, sc, scr

INDICATORS: (Indicators not listed are not affected)

	<u>If division takes place:</u>	<u>If no division takes place:</u>
Zero	If $C(AQ) = 0$, then ON; otherwise OFF	If divisor mantissa = 0, then ON; otherwise OFF
Negative	If $C(AQ)_0 = 1$, then ON; otherwise OFF	If dividend < 0, then ON; otherwise OFF
Exponent Overflow	If exponent is greater than +127, then ON	
Exponent Underflow	If exponent is less than -128, then ON	

NOTES: Except for the interchange of the roles of the operands, the execution of the dfdi instruction is identical to the execution of the dfdv instruction.

If the divisor mantissa $C(AQ)$ is zero, the division does not take place. Instead, a divide check fault occurs and all registers remain unchanged.

dfdv	Double-Precision Floating Divide	567 (0)
------	----------------------------------	---------

FORMAT: Basic instruction format (see Figure 4-1).

SUMMARY: $C(EAQ) / C(Y\text{-pair}) \rightarrow C(EAQ)$

MODIFICATIONS: All except du, dl, ci, sc, scr

INDICATORS: (Indicators not listed are not affected)

FLOATING-POINT DIVISION

	<u>If division takes place:</u>	<u>If no division takes place:</u>
Zero	If $C(AQ) = 0$, then ON; otherwise OFF	If divisor mantissa = 0, then ON; otherwise OFF
Negative	If $C(AQ)_0 = 1$, then ON; otherwise OFF	If dividend < 0, then ON; otherwise OFF
Exponent Overflow	If exponent is greater than +127, then ON	
Exponent Underflow	If exponent is less than -128, then ON	

NOTES:

The dfdv instruction is executed as follows:

The dividend mantissa $C(AQ)$ is shifted right and the dividend exponent $C(E)$ increased accordingly until

$$|C(AQ)_{0,63}| < |C(Y\text{-pair})_{8,71}|$$

$$C(E) - C(Y\text{-pair})_{0,7} \rightarrow C(E)$$

$$C(AQ) / C(Y\text{-pair})_{8,71} \rightarrow C(AQ)_{0,63}$$

$$00\dots0 \rightarrow C(Q)_{64,71}$$

If the divisor mantissa $C(Y\text{-pair})_{8,71}$ is zero after alignment, the division does not take place. Instead, a divide check fault occurs, $C(AQ)$ contains the dividend magnitude, and the negative indicator reflects the dividend sign.

fdi	Floating Divide Inverted	525 (0)
-----	--------------------------	---------

FORMAT: Basic instruction format (see Figure 4-1).

SUMMARY: $C(Y) / C(EAQ) \rightarrow C(EA)$
 $00\dots0 \rightarrow C(Q)$

MODIFICATIONS: All except ci, sc, scr

INDICATORS: (Indicators not listed are not affected)

	<u>If division takes place:</u>	<u>If no division takes place:</u>
Zero	If $C(A) = 0$, then ON; otherwise OFF	If divisor mantissa = 0, then ON; otherwise OFF
Negative	If $C(A)_0 = 1$, then ON; otherwise OFF	If dividend < 0, then ON; otherwise OFF

Exponent Overflow If exponent is greater than +127, then ON

Exponent Underflow If exponent is less than -128, then ON

NOTES: Except for the interchange of roles of the operands, the execution of the fdv instruction is identical to the execution of the fdi instruction.

If the divisor mantissa C(AQ) is zero, the division does not take place. Instead, a divide check fault occurs and all the registers remain unchanged.

fdv	Floating Divide	565 (0)
-----	-----------------	---------

FORMAT: Basic instruction format (see Figure 4-1).

SUMMARY C(EAQ) / C(Y) -> C(EA)
00...0 -> C(Q)

MODIFICATIONS: All except ci, sc, scr

INDICATORS: (Indicators not listed are not affected)

	<u>If division takes place:</u>	<u>If no division takes place:</u>
Zero	If C(A) = 0, then ON; otherwise OFF	If divisor mantissa = 0, then ON; otherwise OFF
Negative	If C(A) ₀ = 1, then ON; otherwise OFF	If dividend < 0, then ON; otherwise OFF
Exponent Overflow	If exponent is greater than +127, then ON	
Exponent Underflow	If exponent is less than -128, then ON	

NOTES: The fdv instruction is executed as follows:

The dividend mantissa C(AQ) is shifted right and the dividend exponent C(E) increased accordingly until

$$|C(AQ)_{0,27}| < |C(Y)_{8,35}|$$

$$C(E) - C(Y)_{0,7} \rightarrow C(E)$$

$$C(AQ) / C(Y)_{8,35} \rightarrow C(A)$$

$$00...0 \rightarrow C(Q)$$

FLOATING-POINT NEGATE

If the divisor mantissa $C(Y)_{8,35}$ is zero after alignment, the division does not take place. Instead, a divide check fault occurs, $C(AQ)$ contains the dividend magnitude, and the negative indicator reflects the dividend sign.

Floating-Point Negate

fneg	Floating Negate	513 (0)
------	-----------------	---------

FORMAT: Basic instruction format (see Figure 4-1).

SUMMARY: $-C(EAQ)$ normalized $\rightarrow C(EAQ)$

MODIFICATIONS: All, but none affect instruction execution.

INDICATORS: (Indicators not listed are not affected)

Zero If $C(AQ) = 0$, then ON; otherwise OFF

Negative If $C(AQ)_0 = 1$, then ON; otherwise OFF

Exponent Overflow If exponent is greater than +127, then ON

Exponent Underflow If exponent is less than -128, then ON

NOTES: This instruction changes the number in $C(EAQ)$ to its normalized negative (if $C(AQ) \neq 0$). The operation is executed by first forming the two's complement of $C(AQ)$, and then normalizing $C(EAQ)$.

Even if originally $C(EAQ)$ were normalized, an exponent overflow can still occur, namely when $C(E) = +127$ and $C(AQ) = 100\dots0$ which is the two's complement approximation for the decimal value -1.0.

The definition of normalization may be found under the description of the fno instruction.

Attempted repetition with the rpl instruction causes an illegal procedure fault.

Floating-Point Normalize

fno	Floating Normalize	573 (0)
-----	--------------------	---------

FORMAT: Basic instruction format (see Figure 4-1).

SUMMARY: C(EAQ) normalized -> C(EAQ)

MODIFICATIONS: All, but none affect instruction execution.

INDICATORS: (Indicators not listed are not affected)

Zero If C(EAQ) = floating point 0, then ON; otherwise OFF

Negative If C(AQ)₀ = 1, then ON; otherwise OFF

Exponent Overflow If exponent is greater than +127, then ON

Exponent Underflow If exponent is less than -128, then ON otherwise OFF

Overflow Set OFF

NOTES: The fno instruction normalizes the number in C(EAQ) if C(AQ) ≠ 0 and the overflow indicator is OFF.

A normalized floating number is defined as one whose mantissa lies in the interval [0.5,1.0] such that

$$0.5 \leq |C(AQ)| < 1.0$$

which, in turn, requires that C(AQ)₀ ≠ C(AQ)₁.

If the overflow indicator is ON, then C(AQ) is shifted one place to the right, C(AQ)₀ is inverted to reconstitute the actual sign, and the overflow indicator is set OFF. This action makes the fno instruction useful in correcting overflows that occur with fixed point numbers.

Normalization is performed by shifting C(AQ)_{1,71} one place to the left and reducing C(E) by 1, repeatedly, until the conditions for C(AQ)₀ and C(AQ)₁ are met. Bits shifted out of AQ₁ are lost.

If C(AQ) = 0, then C(E) is set to -128 and the zero indicator is set ON.

Attempted repetition with the rpl instruction causes an illegal procedure fault.

Floating-Point Round

dfrd	Double-Precision Floating Round	473 (0)
------	---------------------------------	---------

FORMAT: Basic instruction format (see Figure 4-1).

SUMMARY: C(EAQ) rounded to 64 bits -> C(EAQ)
 0 -> C(AQ)_{65,71}

MODIFICATIONS: All, but none affect instruction execution.

INDICATORS: (Indicators not listed are not affected)

Zero If C(EAQ) = floating point 0, then ON; otherwise OFF

Negative If C(AQ)₀ = 1, then ON; otherwise OFF

Exponent Overflow If exponent is greater than +127, then ON

Exponent Underflow If exponent is less than -128, then ON

NOTES: The dfrd instruction is identical to the frd instruction except that the rounding constant used is (11...1)_{65,71} instead of (11...1)_{29,71}.

Attempted repetition with the rpl instruction causes an illegal procedure fault.

frd	Floating Round	471 (0)
-----	----------------	---------

FORMAT: Basic instruction format (see Figure 4-1).

SUMMARY: C(EAQ) rounded to 28 bits -> C(EAQ)
 0 -> C(AQ)_{29,71}

MODIFICATIONS: All, but none affect instruction execution.

INDICATORS: (Indicators not listed are not affected)

Zero If C(EAQ) = floating point 0, then ON; otherwise OFF

Negative If C(AQ)₀ = 1 then ON; otherwise OFF

FLOATING-POINT ROUND

Exponent
Overflow If exponent is greater than +127, then ON

Exponent
Underflow If exponent is less than -128, then ON

NOTES:

If $C(AQ) \neq 0$, the frd instruction performs a true round to a precision of 28 bits and a normalization on $C(EAQ)$.

A true round is a rounding operation such that the sum of the result of applying the operation to two numbers of equal magnitude but opposite sign is exactly zero.

The frd instruction is executed as follows:

$$C(AQ) + (11\dots1)_{29,71} \rightarrow C(AQ)$$

If $C(AQ)_0 = 0$, then a carry is added at AQ_{71}

If overflow occurs, $C(AQ)$ is shifted one place to the right and $C(E)$ is increased by 1.

If overflow does not occur, $C(EAQ)$ is normalized.

If $C(AQ) = 0$, $C(E)$ is set to -128 and the zero indicator is set ON.

Attempted repetition with the rpl instruction causes an illegal procedure fault.

Floating-Point Compare

dfcmg	Double-Precision Floating Compare Magnitude	427 (0)
-------	---	---------

FORMAT: Basic instruction format (see Figure 4-1).

SUMMARY: $C(E) :: C(Y\text{-pair})_{0,7}$
 $|C(AQ)_{0,63}| :: |C(Y\text{-pair})_{8,71}|$

MODIFICATIONS: All except du, dl, ci, sc, scr

INDICATORS: (Indicators not listed are not affected)

Zero If $|C(EAQ)| = |C(Y\text{-pair})|$, then ON; otherwise OFF

Negative If $|C(EAQ)| < |C(Y\text{-pair})|$, then ON; otherwise OFF

NOTES: The dfcmg instruction is identical to the dfcmp instruction except that the magnitudes of the mantissas are compared instead of the algebraic values.

dfcmp	Double-Precision Floating Compare	517 (0)
-------	-----------------------------------	---------

FORMAT: Basic instruction format (see Figure 4-1).

SUMMARY: $C(E) :: C(Y\text{-pair})_{0,7}$
 $C(AQ)_{0,63} :: C(Y\text{-pair})_{8,71}$

MODIFICATIONS: All except du, dl, ci, sc, scr

INDICATORS: (Indicators not listed are not affected)

Zero If $C(EAQ) = C(Y\text{-pair})$, then ON; otherwise OFF

Negative If $C(EAQ) < C(Y\text{-pair})$, then ON; otherwise OFF

NOTES: The dfcmp instruction is identical to the fcmp instruction except for the precision of the mantissas actually compared.

FLOATING-POINT COMPARE

fcmg	Floating Compare Magnitude	425 (0)
------	----------------------------	---------

FORMAT: Basic instruction format (see Figure 4-1).

SUMMARY: $C(E) :: C(Y)_{0,7}$
 $|C(AQ)_{0,27}| :: |C(Y)_{8,35}|$

MODIFICATIONS: All except ci, sc, scr

INDICATORS: (Indicators not listed are not affected)

Zero If $|C(EAQ)| = |C(Y)|$, then ON; otherwise OFF

Negative If $|C(EAQ)| < |C(Y)|$, then ON; otherwise OFF

NOTES: The fcmg instruction is identical to the fcmp instruction except that the magnitudes of the mantissas are compared instead of the algebraic values.

fcmp	Floating Compare	515 (0)
------	------------------	---------

FORMAT: Basic instruction format (see Figure 4-1).

SUMMARY: $C(E) :: C(Y)_{0,7}$
 $C(AQ)_{0,27} :: C(Y)_{8,35}$

MODIFICATIONS: All except ci, sc, scr

INDICATORS: (Indicators not listed are not affected)

Zero If $C(EAQ) = C(Y)$, then ON; otherwise OFF

Negative If $C(EAQ) < C(Y)$, then ON; otherwise OFF

NOTES: The fcmp instruction is executed as follows:

The mantissas are aligned by shifting the mantissa of the operand with the algebraically smaller exponent to the right the number of places equal to the difference in the two exponents.

The aligned mantissas are compared and the indicators set accordingly.

Floating-Point Miscellaneous

ade	Add to Exponent	415 (0)
-----	-----------------	---------

FORMAT: Basic instruction format (see Figure 4-1).

SUMMARY: $C(E) + C(Y)_{0,7} \rightarrow C(E)$

MODIFICATIONS: All except ci, sc, scr

INDICATORS: (Indicators not listed are not affected)

Zero Set OFF

Negative Set OFF

Exponent Overflow If exponent is greater than +127, then ON

Exponent Underflow If exponent is less than -128, then ON

fszn	Floating Set Zero and Negative Indicators	430 (0)
------	---	---------

FORMAT: Basic instruction format (see Figure 4-1).

SUMMARY: Set indicators according to C(Y)

MODIFICATIONS: All except ci, sc, scr

INDICATORS: (Indicators not listed are not affected)

Zero If $C(Y)_{8,35} = 0$, then ON; otherwise OFF

Negative If $C(Y)_8 = 1$, then ON; otherwise OFF

lde	Load Exponent	411 (0)
-----	---------------	---------

FORMAT: Basic instruction format (see Figure 4-1).

SUMMARY: $C(Y)_{0,7} \rightarrow C(E)$

FLOATING-POINT MISCELLANEOUS

MODIFICATIONS: All except ci, sc, scr

INDICATORS: (Indicators not listed are not affected)

Zero Set OFF

Negative Set OFF

ste	Store Exponent	456 (0)
-----	----------------	---------

FORMAT: Basic instruction format (see Figure 4-1).

SUMMARY: C(E) → C(Y)_{0,7}
 00...0 → C(Y)_{8,17}

MODIFICATIONS: All except du, dl, ci, sc, scr

INDICATORS: None affected

TRANSFER INSTRUCTIONS

call6	Call (Using PR6 and PR7)	713 (0)
-------	--------------------------	---------

FORMAT: Basic instruction format (see Figure 4-1).

SUMMARY:

```

If C(TPR.TRR) < C(PPR.PRR) then
    C(DSBR.STACK) || C(TPR.TRR) -> C(PR7.SNR)

If C(TPR.TRR) = C(PPR.PRR) then C(PR6.SNR) -> C(PR7.SNR)
C(TPR.TRR) -> C(PR7.RNR)

If C(TPR.TRR) = 0 then C(SDW.P) -> C(PPR.P);
    otherwise 0 -> C(PPR.P)

00...0 -> C(PR7.WORDNO)
00...0 -> C(PR7.BITNO)

C(TPR.TRR) -> C(PPR.PRR)
C(TPR.TSR) -> C(PPR.PSR)
C(TPR.CA) -> C(PPR.IC)

```

MODIFICATIONS: All except du, dl, ci, sc, scr

INDICATORS: None affected

NOTES: See Section 3 for descriptions of the various registers and Section 8 for a flowchart of their role in address preparation.

If $C(TPR.TRR) > C(PPR.PRR)$, an access violation fault (outward call) occurs and the call6 instruction is not executed.

If the call6 instruction is executed with the processor in absolute mode with bit 29 of the instruction word set OFF and without indirection through an itp or its pair, then:

the appending mode is entered for the address preparation of the call6 operand address and is retained if the instruction executes successfully,

and the effective segment number generated for the SDW fetch and subsequent loading into $C(TPR.TSR)$ is equal to $C(PPR.PSR)$ and may be undefined in absolute mode,

and the effective ring number loaded into $C(TPR.TRR)$ prior to the SDW fetch is equal to $C(PPR.PRR)$ (which is 0 in absolute mode) implying that the access violation checks for outward call and bad outward

TRANSFER

call are ineffective and that an access violation (out of call brackets) will occur if C(SDW.R1) ≠ 0.

Attempted repetition with the rpt, rpd, or rpl instructions causes an illegal procedure fault.

ret	Return	630 (0)
-----	--------	---------

FORMAT: Basic instruction format (see Figure 4-1).

SUMMARY: C(Y)_{0,17} → C(PPR.IC)
C(Y)_{18,31} → C(IR)

MODIFICATIONS: All except du, dl, ci, sc, scr

INDICATORS: (Indicators not listed are not affected)

Parity mask If C(Y)₂₇ = 1, and the processor is in absolute or privileged mode, then ON; otherwise OFF. This indicator is not affected in the normal or BAR modes.

Not BAR mode Can be set OFF but not ON by the ret instruction

Absolute mode Can be set OFF but not ON by the ret instruction

All other indicators If corresponding bit in C(Y) is 1, then ON; otherwise, OFF

NOTES: The relation between C(Y)_{18,31} and the indicators is given in Table 4-5 earlier in this section.

The tally runout indicator reflects C(Y)₂₅ regardless of what address modification is performed on the ret instruction.

The ret instruction may be thought of as a ldi instruction followed by a transfer to location C(Y)_{0,17}.

Attempted repetition with the rpt, rpd, or rpl instructions causes an illegal procedure fault.

rtcd	Return Control Double	610 (0)
------	-----------------------	---------

FORMAT: Basic instruction format (see Figure 4-1).

SUMMARY: C(Y-pair)_{3,17} → C(PPR.PSR)
Maximum of
C(Y-pair)_{18,20}; C(TPR.TRR); C(SDW.R1) → C(PPR.PRR)
C(Y-pair)_{36,53} → C(PPR.IC)
If C(PPR.PRR) = 0 then C(SDW.P) → C(PPR.P);
otherwise 0 → C(PPR.P)
C(PPR.PRR) → C(PRn.RNR) for n = (0, 1, ..., 7)

MODIFICATIONS: All except du, dl, ci, sc, scr

INDICATORS: None affected

NOTES: See Section 3 for descriptions of the various registers and Section 8 for a flowchart of their role in address preparation.

If an access violation fault occurs when fetching the SDW for the Y-pair, the C(PPR.PSR) and C(PPR.PRR) are not altered.

If the rtcd instruction is executed with the processor in absolute mode with bit 29 of the instruction word set OFF and without indirection through an itp or its pair, then:

- appending mode is entered for address preparation for the rtcd operand and is retained if the instruction executes successfully,
- and the effective segment number generated for the SDW fetch and subsequent loading into C(TPR.TSR) is equal to C(PPR.PSR) and may be undefined in absolute mode,
- and the effective ring number loaded into C(TPR.TRR) prior to the SDW fetch is equal to C(PPR.PRR) (which is 0 in absolute mode) implying that control is always transferred into ring 0.

Attempted repetition with the rpt, rpd, or rpl instructions causes an illegal procedure fault.

TRANSFER

teo	Transfer on Exponent Overflow	614 (0)
-----	-------------------------------	---------

FORMAT: Basic instruction format (see Figure 4-1).

SUMMARY: If exponent overflow indicator ON then
 C(TPR.CA) -> C(PPR.IC)
 C(TPR.TSR) -> C(PPR.PSR)
 otherwise, no change to C(PPR)

MODIFICATIONS: All except du, dl, ci, sc, scr

INDICATORS: (Indicators not listed are not affected)

Exponent
overflow Set OFF

NOTES: Attempted repetition with the rpt, rpd, or rpl instructions causes an illegal procedure fault.

teu	Transfer on Exponent Underflow	615 (0)
-----	--------------------------------	---------

FORMAT: Basic instruction format (see Figure 4-1).

SUMMARY: If exponent underflow indicator ON then
 C(TPR.CA) -> C(PPR.IC)
 C(TPR.TSR) -> C(PPR.PSR)
 otherwise, no change to C(PPR)

MODIFICATIONS: All except du, dl, ci, sc, scr

INDICATORS: (Indicators not listed are not affected)

Exponent
underflow Set OFF

NOTES: Attempted repetition with the rpt, rpd, or rpl instructions causes an illegal procedure fault.

tmi	Transfer on Minus	604 (0)
-----	-------------------	---------

FORMAT: Basic instruction format (see Figure 4-1).

SUMMARY: If negative indicator ON then
C(TPR.CA) -> C(PPR.IC)
C(TPR.TSR) -> C(PPR.PSR)
otherwise, no change to C(PPR)

MODIFICATIONS: All except du, dl, ci, sc, scr

INDICATORS: None affected

NOTES: Attempted repetition with the rpt, rpd, or rpl instructions causes an illegal procedure fault.

tmoz	Transfer on Minus or Zero	604 (1)
------	---------------------------	---------

FORMAT: Basic instruction format (see Figure 4-1).

SUMMARY: If negative or zero indicator ON then
C(TPR.CA) -> C(PPR.IC)
C(TPR.TSR) -> C(PPR.PSR)
otherwise, no change to C(PPR)

MODIFICATIONS: All except du, dl, ci, sc, scr

INDICATORS: None affected

NOTES: Attempted repetition with the rpt, rpd, or rpl instructions causes an illegal procedure fault.

tnc	Transfer on No Carry	602 (0)
-----	----------------------	---------

FORMAT: Basic instruction format (see Figure 4-1).

TRANSFER

SUMMARY: If carry indicator OFF then
 C(TPR.CA) -> C(PPR.IC)
 C(TPR.TSR) -> C(PPR.PSR)
 otherwise, no change to C(PPR)

MODIFICATIONS: All except du, dl, ci, sc, scr

INDICATORS: None affected

NOTES: Attempted repetition with the rpt, rpd, or rpl instructions causes an illegal procedure fault.

tnz	Transfer on Nonzero	601 (0)
-----	---------------------	---------

FORMAT: Basic instruction format (see Figure 4-1).

SUMMARY: If zero indicator OFF then
 C(TPR.CA) -> C(PPR.IC)
 C(TPR.TSR) -> C(PPR.PSR)
 otherwise, no change to C(PPR)

MODIFICATIONS: All except du, dl, ci, sc, scr

INDICATORS: None affected

NOTES: Attempted repetition with the rpt, rpd, or rpl instructions causes an illegal procedure fault.

tov	Transfer on Overflow	617 (0)
-----	----------------------	---------

FORMAT: Basic instruction format (see Figure 4-1).

SUMMARY: If overflow indicator ON then
 C(TPR.CA) -> C(PPR.IC)
 C(TPR.TSR) -> C(PPR.PSR)
 otherwise, no change to C(PPR)

MODIFICATIONS: All except du, dl, ci, sc, scr

INDICATORS: (Indicators not listed are not affected)

Overflow Set OFF

NOTES: Attempted repetition with the rpt, rpd, or rpl instructions causes an illegal procedure fault.

tpl	Transfer on Plus	605 (0)
-----	------------------	---------

FORMAT: Basic instruction format (see Figure 4-1).

SUMMARY: If negative indicator OFF, then

C(TPR.CA) -> C(PPR.IC)

C(TPR.TSR) -> C(PPR.PSR)

otherwise, no change to C(PPR)

MODIFICATIONS: All except du, dl, ci, sc, scr

INDICATORS: None affected

NOTES: Attempted repetition with the rpt, rpd, or rpl instructions causes an illegal procedure fault.

tpnz	Transfer on Plus and Nonzero	605 (1)
------	------------------------------	---------

FORMAT: Basic instruction format (see Figure 4-1).

SUMMARY: If negative and zero indicators are OFF then

C(TPR.CA) -> C(PPR.IC)

C(TPR.TSR) -> C(PPR.PSR)

otherwise, no change to C(PPR)

MODIFICATIONS: All except du, dl, ci, sc, scr

INDICATORS: None affected

TRANSFER

NOTES: Attempted repetition with the rpt, rpd, or rpl instructions causes an illegal procedure fault.

tra	Transfer Unconditionally	710 (0)
-----	--------------------------	---------

FORMAT: Basic instruction format (see Figure 4-1).

SUMMARY: C(TPR.CA) -> C(PPR.IC)
C(TPR.TSR) -> C(PPR.PSR)

MODIFICATIONS: All except du, dl, ci, sc, scr

INDICATORS: None affected

NOTES: Attempted repetition with the rpt, rpd, or rpl instructions causes an illegal procedure fault.

trc	Transfer on Carry	603 (0)
-----	-------------------	---------

FORMAT: Basic instruction format (see Figure 4-1).

SUMMARY: If carry indicator ON then
C(TPR.CA) -> C(PPR.IC)
C(TPR.TSR) -> C(PPR.PSR)
otherwise, no change to C(PPR)

MODIFICATIONS: All except du, dl, ci, sc, scr

INDICATORS: None affected

NOTES: Attempted repetition with the rpt, rpd, or rpl instructions causes an illegal procedure fault.

trtf	Transfer on Truncation Indicator OFF	601 (1)
------	--------------------------------------	---------

FORMAT: Basic instruction format (see Figure 4-1).

SUMMARY: If truncation indicator OFF then
 C(TPR.CA) -> C(PPR.IC)
 C(TPR.TSR) -> C(PPR.PSR)
 otherwise, no change to C(PPR)

MODIFICATIONS: All except du, dl, ci, sc, scr

INDICATORS: None affected

NOTES: Attempted repetition with the rpt, rpd, or rpl instructions causes an illegal procedure fault.

trtn	Transfer on Truncation Indicator ON	600 (1)
------	-------------------------------------	---------

FORMAT: Basic instruction format (see Figure 4-1).

SUMMARY: If truncation indicator ON then
 C(TPR.CA) -> C(PPR.IC)
 C(TPR.TSR) -> C(PPR.PSR)
 otherwise, no change to C(PPR)

MODIFICATIONS: All except du, dl, ci, sc, scr

INDICATORS: (Indicators not listed are not affected)

Truncation Set OFF

NOTES: Attempted repetition with the rpt, rpd, or rpl instructions causes an illegal procedure fault.

TRANSFER

tsp0	Transfer and Set Pointer Register 0	270 (0)
tsp1	Transfer and Set Pointer Register 1	271 (0)
tsp2	Transfer and Set Pointer Register 2	272 (0)
tsp3	Transfer and Set Pointer Register 3	273 (0)
tsp4	Transfer and Set Pointer Register 4	670 (0)
tsp5	Transfer and Set Pointer Register 5	671 (0)
tsp6	Transfer and Set Pointer Register 6	672 (0)
tsp7	Transfer and Set Pointer Register 7	673 (0)

FORMAT: Basic instruction format (see Figure 4-1).

SUMMARY: For n = 0, 1, ..., or 7 as determined by operation code

C(PPR.PRR) -> C(PRn.RNR)

C(PPR.PSR) -> C(PRn.SNR)

C(PPR.IC) + 1 -> C(PRn.WORDNO)

00...0 -> C(PRn.BITNO)

C(TPR.CA) -> C(PPR.IC)

C(TPR.TSR) -> C(PPR.PSR)

MODIFICATIONS: All except du, dl, ci, sc, scr

INDICATORS: None affected

NOTES: Attempted repetition with the rpt, rpd, or rpl instructions causes an illegal procedure fault.

tss	Transfer and Set Slave	715 (0)
-----	------------------------	---------

FORMAT: Basic instruction format (see Figure 4-1).

SUMMARY: C(TPR.CA) + (BAR base) -> C(PPR.IC)

C(TPR.TSR) -> C(PPR.PSR)

MODIFICATIONS: All except du, dl, ci, sc, scr

INDICATORS: (Indicators not listed are not affected)

Not BAR mode Set OFF (see notes below)

Absolute mode Set OFF

NOTES: If the tss instruction is executed with the processor not in BAR mode the not BAR mode indicator is set OFF to enable subsequent addressing in the BAR mode. The base address register (BAR) is used in the address preparation of the transfer, and the BAR will be used in address preparation for all subsequent instructions until a fault or interrupt occurs. *

If the tss instruction is executed with the not BAR mode indicator already OFF, it functions as a tra instruction and no indicators are changed.

If C(TPR.CA) >= (BAR bound) the transfer does not take place. Instead, a store fault (out of bounds) occurs.

Attempted repetition with the rpt, rpd, or rpl instructions causes an illegal procedure fault.

tsxn	Transfer and Set Index Register <u>n</u>	70n (0)
------	--	---------

FORMAT: Basic instruction format (see Figure 4-1).

SUMMARY: For n = 0, 1, ..., or 7 as determined by operation code

C(PPR.IC) + 1 -> C(Xn)

C(TPR.CA) -> C(PPR.IC)

C(TPR.TSR) -> C(PPR.PSR)

MODIFICATIONS: All except du, dl, ci, sc, scr

INDICATORS: None affected

NOTES: Attempted repetition with the rpt, rpd, or rpl instructions causes an illegal procedure fault.

TRANSFER

ttf	Transfer on Tally Runout Indicator OFF	607 (0)
-----	--	---------

FORMAT: Basic instruction format (see Figure 4-1).

SUMMARY: If tally runout indicator OFF then
 C(TPR.CA) -> C(PPR.IC)
 C(TPR.TSR) -> C(PPR.PSR)
 otherwise, no change to C(PPR)

MODIFICATIONS: All except du, dl, ci, sc, scr

INDICATORS: None affected

NOTES: Attempted repetition with the rpt, rpd, or rpl instructions causes an illegal procedure fault.

ttn	Transfer on Tally Runout Indicator ON	606 (1)
-----	---------------------------------------	---------

FORMAT: Basic instruction format (see Figure 4-1).

SUMMARY: If tally runout indicator ON then
 C(TPR.CA) -> C(PPR.IC)
 C(TPR.TSR) -> C(PPR.PSR)
 otherwise, no change to C(PPR)

MODIFICATIONS: All except du, dl, ci, sc, scr

INDICATORS: None affected

NOTES: Attempted repetition with the rpt, rpd, or rpl instructions causes an illegal procedure fault.

tze	Transfer on Zero	600 (0)
-----	------------------	---------

FORMAT: Basic instruction format (see Figure 4-1).

SUMMARY: If zero indicator ON then
C(TPR.CA) -> C(PPR.IC)
C(TPR.TSR) -> C(PPR.PSR)
otherwise, no change to C(PPR)

MODIFICATIONS: All except du, dl, ci, sc, scr

INDICATORS: None affected

NOTES: Attempted repetition with the rpt, rpd, or rpl
instructions causes an illegal procedure fault.

POINTER REGISTER DATA MOVEMENT LOAD

POINTER REGISTER INSTRUCTIONS

Pointer Register Data Movement Load

easp0	Effective Address to Segment Number of Pointer Register 0	311 (0)
easp1	Effective Address to Segment Number of Pointer Register 1	310 (1)
easp2	Effective Address to Segment Number of Pointer Register 2	313 (0)
easp3	Effective Address to Segment Number of Pointer Register 3	312 (1)
easp4	Effective Address to Segment Number of Pointer Register 4	331 (0)
easp5	Effective Address to Segment Number of Pointer Register 5	330 (1)
easp6	Effective Address to Segment Number of Pointer Register 6	333 (0)
easp7	Effective Address to Segment Number of Pointer Register 7	332 (1)

FORMAT: Basic instruction format (see Figure 4-1).

SUMMARY: For n = 0, 1, ..., or 7 as determined by operation code
C(TPR.CA) -> C(PRn.SNR)

MODIFICATIONS: All except du, dl, ci, sc, scr

INDICATORS: None affected

NOTES: Attempted execution in BAR mode causes an illegal procedure fault.

Attempted repetition with the rpt, rpd, or rpl instructions causes an illegal procedure fault.

eawp0	Effective Address to Word/Bit Number of Pointer Register 0	310 (0)
eawp1	Effective Address to Word/Bit Number of Pointer Register 1	311 (1)
eawp2	Effective Address to Word/Bit Number of Pointer Register 2	312 (0)
eawp3	Effective Address to Word/Bit Number of Pointer Register 3	313 (1)
eawp4	Effective Address to Word/Bit Number of Pointer Register 4	330 (0)
eawp5	Effective Address to Word/Bit Number of Pointer Register 5	331 (1)
eawp6	Effective Address to Word/Bit Number of Pointer Register 6	332 (0)
eawp7	Effective Address to Word/Bit Number of Pointer Register 7	333 (1)

FORMAT: Basic instruction format (see Figure 4-1).

SUMMARY: For n = 0, 1, ..., or 7 as determined by operation code
 C(TPR.CA) -> C(PRn.WORDNO)
 C(TPR.TBR) -> C(PRn.BITNO)

MODIFICATIONS: All except du, dl, ci, sc, scr

INDICATORS: None affected

NOTES: Attempted execution in BAR mode causes an illegal procedure fault.

Attempted repetition with the rpt, rpd, or rpl instructions causes an illegal procedure fault.

POINTER REGISTER DATA MOVEMENT LOAD

epbp0	Effective Pointer at Base to Pointer Register 0	350 (1)
epbp1	Effective Pointer at Base to Pointer Register 1	351 (0)
epbp2	Effective Pointer at Base to Pointer Register 2	352 (1)
epbp3	Effective Pointer at Base to Pointer Register 3	353 (0)
epbp4	Effective Pointer at Base to Pointer Register 4	370 (1)
epbp5	Effective Pointer at Base to Pointer Register 5	371 (0)
epbp6	Effective Pointer at Base to Pointer Register 6	372 (1)
epbp7	Effective Pointer at Base to Pointer Register 7	373 (0)

FORMAT: Basic instruction format (see Figure 4-1).

SUMMARY: For n = 0, 1, ..., or 7 as determined by operation code
 C(TPR.TRR) -> C(PRn.RNR)
 C(TPR.TSR) -> C(PRn.SNR)
 00...0 -> C(PRn.WORDNO)
 * 0000 -> C(PRn.BITNO)

MODIFICATIONS: All except du, dl, ci, sc, scr

INDICATORS: None affected

NOTES: Attempted execution in BAR mode causes an illegal procedure fault.
 Attempted repetition with the rpt, rpd, or rpl instructions causes an illegal procedure fault.

epp0	Effective Pointer to Pointer Register 0	350 (0)
epp1	Effective Pointer to Pointer Register 1	351 (1)
epp2	Effective Pointer to Pointer Register 2	352 (0)
epp3	Effective Pointer to Pointer Register 3	353 (1)
epp4	Effective Pointer to Pointer Register 4	370 (0)
epp5	Effective Pointer to Pointer Register 5	371 (1)
epp6	Effective Pointer to Pointer Register 6	372 (0)
epp7	Effective Pointer to Pointer Register 7	373 (1)

FORMAT: Basic instruction format (see Figure 4-1).

SUMMARY: For n = 0, 1, ..., or 7 as determined by operation code

C(TPR.TRR) -> C(PRn.RNR)

C(TPR.TSR) -> C(PRn.SNR)

C(TPR.CA) -> C(PRn.WORDNO)

C(TPR.TBR) -> C(PRn.BITNO)

MODIFICATIONS: All except du, dl, ci, sc, scr

INDICATORS: None affected

NOTES: Attempted execution in BAR mode causes an illegal procedure fault.

Attempted repetition with the rpt, rpd, or rpl instructions causes an illegal procedure fault.

POINTER REGISTER DATA MOVEMENT LOAD

lpri	Load Pointer Registers from ITS Pairs	173 (0)
------	---------------------------------------	---------

FORMAT: Basic instruction format (see Figure 4-1).

SUMMARY: For $n = 0, 1, \dots, 7$

$$Y\text{-pair} = Y\text{-block16} + 2n$$

Maximum of
 $C(Y\text{-pair})_{18,20}; C(SDW.R1); C(TPR.TRR) \rightarrow C(PRn.RNR)$

$C(Y\text{-pair})_{3,17} \rightarrow C(PRn.SNR)$

$C(Y\text{-pair})_{36,53} \rightarrow C(PRn.WORDNO)$

$C(Y\text{-pair})_{57,62} \rightarrow C(PRn.BITNO)$

MODIFICATIONS: All except du, dl, ci, sc, scr

INDICATORS: None Affected

NOTES: Starting at location Y-block16, the contents of eight word pairs (in its pair format) replace the contents of pointer registers 0 through 7 as shown.

Since $C(TPR.TRR)$ and $C(SDW.R1)$ are both equal to zero in absolute mode, $C(Y\text{-pair})_{18,20}$ are loaded into $PRn.RNR$ in absolute mode.

Attempted execution in BAR mode causes an illegal procedure fault.

Attempted repetition with the rpt, rpd, or rpl instructions causes an illegal procedure fault.

lprpn	Load Pointer Register <u>n</u> Packed	76n (0)
-------	---------------------------------------	---------

FORMAT: Basic instruction format (see Figure 4-1).

SUMMARY: For $n = 0, 1, \dots, \text{or } 7$ as determined by operation code

$C(TPR.TRR) \rightarrow C(PRn.RNR)$

If $C(Y)_{0,1} \neq 11$, then
 $C(Y)_{0,5} \rightarrow C(PRn.BITNO)$;
 otherwise, generate command fault

If $C(Y)_{6,17} = 11\dots 1$, then $111 \rightarrow C(PRn.SNR)_{0,2}$
 otherwise, $000 \rightarrow C(PRn.SNR)_{0,2}$

$C(Y)_{6,17} \rightarrow C(PRn.SNR)_{3,14}$

C(Y)_{18,35} -> C(PRn.WORDNO)

MODIFICATIONS: All except du, dl, ci, sc, scr

INDICATORS: None affected

NOTES: Binary 1s in C(Y)_{0,1} correspond to an illegal BITNO, that is, a bit position beyond the extent of C(Y). Detection of these bits causes a command fault.

Attempted execution in BAR mode causes an illegal procedure fault.

Attempted repetition with the rpt, rpd, or rpl instructions causes an illegal procedure fault.

POINTER REGISTER DATA MOVEMENT STORE

Pointer Register Data Movement Store

spbp0	Store Segment Base Pointer of Pointer Register 0	250 (1)
spbp1	Store Segment Base Pointer of Pointer Register 1	251 (0)
spbp2	Store Segment Base Pointer of Pointer Register 2	252 (1)
spbp3	Store Segment Base Pointer of Pointer Register 3	253 (0)
spbp4	Store Segment Base Pointer of Pointer Register 4	650 (1)
spbp5	Store Segment Base Pointer of Pointer Register 5	651 (0)
spbp6	Store Segment Base Pointer of Pointer Register 6	652 (1)
spbp7	Store Segment Base Pointer of Pointer Register 7	653 (0)

FORMAT: Basic instruction format (see Figure 4-1).

SUMMARY: For $n = 0, 1, \dots, \text{or } 7$ as determined by operation code

$C(\text{PRn.SNR}) \rightarrow C(\text{Y-pair})_{3,17}$

$C(\text{PRn.RNR}) \rightarrow C(\text{Y-pair})_{18,20}$

$000 \rightarrow C(\text{Y-pair})_{0,2}$

$00\dots0 \rightarrow C(\text{Y-pair})_{21,29}$

$(43)_8 \rightarrow C(\text{Y-pair})_{30,35}$

$00\dots0 \rightarrow C(\text{Y-pair})_{36,71}$

MODIFICATIONS: All except du, dl, ci, sc, scr

INDICATORS: None affected

NOTES: Attempted execution in BAR mode causes an illegal procedure fault.

Attempted repetition with the rpt, rpd, or rpl instructions causes an illegal procedure fault.

spri	Store Pointer Registers as ITS Pairs	254 (0)
------	--------------------------------------	---------

FORMAT: Basic instruction format (see Figure 4-1).

SUMMARY: For $n = 0, 1, \dots, 7$

Y-pair = Y-block16 + 2n

000 → C(Y-pair)_{0,2}

C(PRn.SNR) → C(Y-pair)_{3,17}

C(PRn.RNR) → C(Y-pair)_{18,20}

00...0 → C(Y-pair)_{21,29}

(43)₈ → C(Y-pair)_{30,35}

C(PRn.WORDNO) → C(Y-pair)_{36,53}

000 → C(Y-pair)_{54,56}

C(PRn.BITNO) → C(Y-pair)_{57,62}

00...0 → C(Y-pair)_{63,71}

MODIFICATIONS: All except du, dl, ci, sc, scr

INDICATORS: None affected

NOTES: Starting at location Y-block16, the contents of pointer registers 0 through 7 replace the contents of eight word pairs (in its pair format).

Attempted execution in BAR mode causes an illegal procedure fault.

Attempted repetition with the rpt, rpd, or rpl instructions causes an illegal procedure fault.

POINTER REGISTER DATA MOVEMENT STORE

spri0	Store Pointer Register 0 as ITS Pair	250 (0)
spri1	Store Pointer Register 1 as ITS Pair	251 (1)
spri2	Store Pointer Register 2 as ITS Pair	252 (0)
spri3	Store Pointer Register 3 as ITS Pair	253 (1)
spri4	Store Pointer Register 4 as ITS Pair	650 (0)
spri5	Store Pointer Register 5 as ITS Pair	651 (1)
spri6	Store Pointer Register 6 as ITS Pair	652 (0)
spri7	Store Pointer Register 7 as ITS Pair	653 (1)

FORMAT: Basic instruction format (see Figure 4-1).

SUMMARY: For $n = 0, 1, \dots, \text{or } 7$ as determined by operation code

$000 \rightarrow C(Y\text{-pair})_{0,2}$
 $C(PRn.SNR) \rightarrow C(Y\text{-pair})_{3,17}$
 $C(PRn.RNR) \rightarrow C(Y\text{-pair})_{18,20}$
 $00\dots0 \rightarrow C(Y\text{-pair})_{21,29}$
 $(43)_8 \rightarrow C(Y\text{-pair})_{30,35}$
 $C(PRn.WORDNO) \rightarrow C(Y\text{-pair})_{36,53}$
 $000 \rightarrow C(Y\text{-pair})_{54,56}$
 $C(PRn.BITNO) \rightarrow C(Y\text{-pair})_{57,62}$
 $00\dots0 \rightarrow C(Y\text{-pair})_{63,71}$

MODIFICATIONS: All except du, dl, ci, sc, scr

INDICATORS: None affected

NOTES: Attempted execution in BAR mode causes an illegal procedure fault.

Attempted repetition with the rpt, rpd, or rpl instructions causes an illegal procedure fault.

sprpn	Store Pointer Register <u>n</u> Packed	54n (0).
-------	--	----------

FORMAT: Basic instruction format (see Figure 4-1).

SUMMARY: For n = 0, 1, ..., or 7 as determined by operation code

C(PRn.BITNO) → C(Y)_{0,5}

C(PRn.SNR)_{3,14} → C(Y)_{6,17}

C(PRn.WORDNO) → C(Y)_{18,35}

MODIFICATIONS: All except du, dl, ci, sc, scr

INDICATORS: None affected

NOTES: If C(PRn.SNR)_{0,2} are nonzero, and C(PRn.SNR) ≠ 11...1, then a store fault (illegal pointer) will occur and C(Y) will not be changed.

Attempted execution in BAR mode causes an illegal procedure fault.

Attempted repetition with the rpt, rpd, or rpl instructions causes an illegal procedure fault.

POINTER REGISTER ADDRESS ARITHMETIC.

Pointer Register Address Arithmetic

adwp0	Add to Word Number of Pointer Register 0	050 (0)
adwp1	Add to Word Number of Pointer Register 1	051 (0)
adwp2	Add to Word Number of Pointer Register 2	052 (0)
adwp3	Add to Word Number of Pointer Register 3	053 (0)
adwp4	Add to Word Number of Pointer Register 4	150 (0)
adwp5	Add to Word Number of Pointer Register 5	151 (0)
adwp6	Add to Word Number of Pointer Register 6	152 (0)
adwp7	Add to Word Number of Pointer Register 7	153 (0)

FORMAT: Basic instruction format (see Figure 4-1).

SUMMARY: For $n = 0, 1, \dots, \text{or } 7$ as determined by operation code
 $C(Y)_{0,17} + C(\text{PRn.WORDNO}) \rightarrow C(\text{PRn.WORDNO})$
 $00\dots0 \rightarrow C(\text{PRn.BITNO})$

MODIFICATIONS: All except dl, ci, sc, scr

INDICATORS: None affected

NOTES: Attempted execution in BAR mode causes an illegal procedure fault.
 Attempted repetition with the rpt, rpd, or rpl instructions causes an illegal procedure fault.

Pointer Register Miscellaneous

epaq	Effective Pointer to AQ	213 (0)
------	-------------------------	---------

FORMAT: Basic instruction format (see Figure 4-1).

SUMMARY: 000 -> C(AQ)_{0,2}
 C(TPR.TSR) -> C(AQ)_{3,17}
 00...0 -> C(AQ)_{18,32}
 C(TPR.TRR) -> C(AQ)_{33,35}
 C(TPR.CA) -> C(AQ)_{36,53}
 00...0 -> C(AQ)_{54,65}
 C(TPR.TBR) -> C(AQ)_{66,71}

MODIFICATIONS: All except du, dl, ci, sc, scr

INDICATORS: (Indicators not listed are not affected)

Zero If C(AQ) = 0, then ON; otherwise OFF

NOTES: Attempted execution in BAR mode causes an illegal procedure fault.
 Attempted repetition with the rpt, rpd, or rpl instructions causes an illegal procedure fault.

CALENDAR CLOCK

MISCELLANEOUS INSTRUCTIONS

Calendar Clock

rcc1	Read Calendar Clock	633 (0)
------	---------------------	---------

FORMAT: Basic instruction format (see Figure 4-1).

SUMMARY: 00...0 -> C(AQ)_{0,19}
C(calendar clock) -> C(AQ)_{20,71}

MODIFICATIONS: All except du, dl, ci, sc, scr

INDICATORS: None affected

NOTES: C(TPR.CA)_{0,2} (C(TPR.CA)_{1,2} for the DPS 8M processor) specify which processor port (i.e., which system controller) is to be used. The contents of the clock in the designated system controller replace the contents of the AQ-register.

Attempted execution in BAR mode causes an illegal procedure fault.

Attempted repetition with the rpt, rpd, or rpl instructions causes an illegal procedure fault.

Derail

drl	Derail	002 (0)
-----	--------	---------

FORMAT: Basic instruction format (see Figure 4-1).

SUMMARY: Causes a fault which fetches and executes, in absolute mode, the instruction pair at main memory location $C+(14)_8$. The value of C is obtained from the FAULT VECTOR switches on the processor configuration panel.

MODIFICATIONS: All, but none affect instruction execution

INDICATORS: None affected

NOTES: Except for the different constant used for fetching the instruction pair from main memory, the drl instruction is identical to the mme instruction.

Attempted repetition with the rpt, rpd, or rpl instructions causes an illegal procedure fault.

:c	Execute	716 (0)
----	---------	---------

FORMAT: Basic instruction format (see Figure 4-1).

SUMMARY: Fetch and execute the instruction in C(Y)

MODIFICATIONS: All except du, dl, ci, sc, scr

INDICATORS: None affected

NOTES: The xec instruction itself does not affect any indicator. However, the execution of the instruction from C(Y) may affect indicators.

If the execution of the instruction from C(Y) modifies C(PPR.IC), then a transfer of control occurs; otherwise, the next instruction to be executed is fetched from C(PPR.IC)+1.

To execute a rpd instruction, the xec instruction must be in an odd location. The instruction pair repeated is that instruction pair at C(PPR.IC)+1, that is, the instruction pair immediately following the xec instruction. C(PPR.IC) is adjusted during the execution of the repeated instruction pair so that the next instruction fetched for execution is from the first word following the repeated instruction pair.

EIS multiword instructions may be executed with the xec instruction but the required operand descriptors must be located immediately after the xec instruction, that is, starting at C(PPR.IC)+1. C(PPR.IC) is adjusted during execution of the EIS multiword instruction so that the next instruction fetched for execution is from the first word following the EIS operand descriptors.

Attempted repetition with the rpt, rpd, or rpl instructions causes an illegal procedure fault.

xed	Execute Double	717 (0)
-----	----------------	---------

FORMAT: Basic instruction format (see Figure 4-1).

SUMMARY: Fetch and execute the instruction pair at C(Y-pair)

MODIFICATIONS: All except du, dl, ci, sc, scr

INDICATORS: None affected

NOTES: The xed instruction itself does not affect any indicator. However, the execution of the instruction pair from C(Y-pair) may affect indicators.

The even instruction from C(Y-pair) must not alter C(Y-pair)_{36,71}, and must not be another xed instruction.

If the execution of the instruction pair from C(Y-pair) alters C(PPR.IC), then a transfer of control occurs; otherwise, the next instruction to be executed is fetched from C(PPR.IC)+1. If the even instruction from C(Y-pair) alters C(PPR.IC), then the transfer of control is effective immediately and the odd instruction is not executed.

To execute an instruction pair having an rpd instruction as the odd instruction, the xed instruction must be located at an odd address. The instruction pair repeated is that instruction pair at C(PPR.IC)+1, that is, the instruction pair immediately following the xed instruction. C(PPR.IC) is adjusted during the execution of the repeated instruction pair so the the next instruction fetched for execution is from the first word following the repeated instruction pair.

The instruction pair at C(Y-pair) may cause any of the processor defined fault conditions, but only the directed faults (0,1,2,3) and the access violation fault may be restarted successfully by the hardware. Note that the software induced fault tag (1,2,3) faults cannot be properly restarted.

An attempt to execute an EIS multiword instruction causes an illegal procedure fault.

Attempted repetition with the rpt, rpd, or rpl instructions causes an illegal procedure fault.

MASTER MODE ENTRY

Master Mode Entry

mme	Master Mode Entry	001 (0)
-----	-------------------	---------

- FORMAT:** Basic instruction format (see Figure 4-1).
- SUMMARY:** Causes a fault that fetches and executes, in absolute mode, the instruction pair at main memory location C+4. The value of C is obtained from the FAULT VECTOR switches on the processor configuration panel.
- MODIFICATIONS:** All, but none affect instruction execution
- INDICATORS:** None affected
- NOTES:** Execution of the mme instruction implies the following conditions:
- During the execution of the mme instruction and the two instructions fetched, the processor is temporarily in absolute mode independent of the value of the absolute mode indicator. The processor stays in absolute mode if the absolute mode indicator is ON after the execution of the instructions.
 - The instruction at C+4 must not alter the contents of main memory location C+5, and must not be an xed instruction.
 - If the contents of the instruction counter (PPR.IC) are changed during execution of the instruction pair at C+4, the next instruction is fetched from the modified C(PPR.IC); otherwise, the next instruction is fetched from C(PPR.IC)+1.
 - If the instruction at C+4 alters C(PPR.IC), then this transfer of control is effective immediately, and the instruction at C+5 is not executed.
 - Attempted repetition with the rpt, rpd, or rpl instructions causes an illegal procedure fault.

mme2	Master Mode Entry 2	004 (0)
------	---------------------	---------

FORMAT: Basic instruction format (see Figure 4-1).

SUMMARY: Causes a fault that fetches and executes, in absolute mode, the instruction pair at main memory location $C+(52)_8$. The value of C is obtained from the FAULT VECTOR switches on the processor configuration panel.

MODIFICATIONS: All, but none affect instruction execution

INDICATORS: None affected

NOTES: Attempted execution in BAR mode causes an illegal procedure fault.

Except for the different constant used for fetching the instruction pair from main memory, the mme2 instruction is identical to the mme instruction.

Attempted repetition with the rpt, rpd, or rpl instructions causes an illegal procedure fault.

mme3	Master Mode Entry 3	005 (0)
------	---------------------	---------

FORMAT: Basic instruction format (see Figure 4-1).

SUMMARY: Causes a fault that fetches and executes, in absolute mode, the instruction pair at main memory location $C+(54)_8$. The value of C is obtained from the FAULT VECTOR switches on the processor configuration panel.

MODIFICATIONS: All, but none affect instruction execution

INDICATORS: None affected

NOTES: Attempted execution in BAR mode causes an illegal procedure fault.

Except for the different constant used for fetching the instruction pair from main memory, the mme3 instruction is identical to the mme instruction.

Attempted repetition with the rpt, rpd, or rpl instructions causes an illegal procedure fault.

MASTER MODE ENTRY

mme4	Master Mode Entry 4	007 (0)
------	---------------------	---------

- FORMAT:** Basic instruction format (see Figure 4-1).
- SUMMARY:** Causes a fault that fetches and executes, in absolute mode, the instruction pair at main memory location $C+(56)_8$. The value of C is obtained from the FAULT VECTOR switches on the processor configuration panel.
- MODIFICATIONS:** All, but none affect instruction execution
- INDICATORS:** None affected
- NOTES:** Attempted execution in BAR mode causes an illegal procedure fault.
- Except for the different constant used for fetching the instruction pair from main memory, the mme4 instruction is identical to the mme instruction.
- Attempted repetition with the rpt, rpd, or rpl instructions causes an illegal procedure fault.

No Operation

nop	No Operation	011 (0)
-----	--------------	---------

FORMAT: Basic instruction format (see Figure 4-1).

SUMMARY: No operation takes place

MODIFICATIONS: All

INDICATORS: None affected (except as noted below)

NOTES: No operation takes place but address preparation is performed according to the specified modifier, if any. If modification other than du or dl is used, the computed addresses generated may cause faults.

The use of indirect then tally modifiers causes changes in the address and tally fields of the referenced indirect words and the tally runout indicator may be set ON as a result.

Attempted repetition with the rpt, rpd, or rpl instructions causes an illegal procedure fault.

puls1	Pulse One	012 (0)
-------	-----------	---------

FORMAT: Basic instruction format (see Figure 4-1).

SUMMARY: No operation takes place

MODIFICATIONS: All

INDICATORS: None affected (except as noted below)

NOTES: The puls1 instruction is identical to the nop instruction except that it causes certain unique synchronizing signals to appear in the processor logic circuitry.

Attempted repetition with the rpt, rpd, or rpl instructions causes an illegal procedure fault.

NO OPERATION

puls2	Pulse Two	013 (0)
-------	-----------	---------

FORMAT: Basic instruction format (see Figure 4-1).

SUMMARY: No operation takes place

MODIFICATIONS: All

INDICATORS: None affected (except as noted below)

NOTES: The puls2 instruction is identical to the nop instruction except that it causes certain unique synchronizing signals to appear in the processor logic circuitry.

Attempted repetition with the rpt, rpd, or rpl instructions causes an illegal procedure fault.

Repeat

rpd	Repeat Double	560 (0)
-----	---------------	---------

FORMAT:

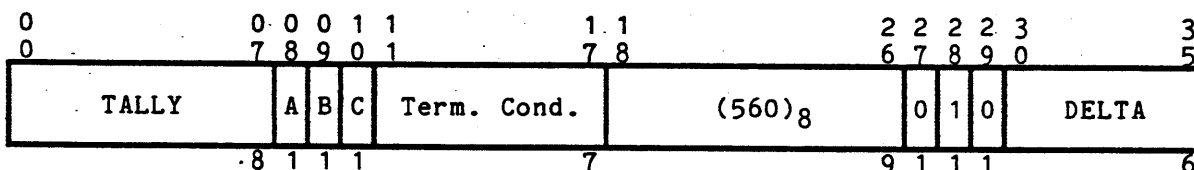

Figure 4-9. Repeat Double (rpd) Instruction Word Format

SUMMARY: Execute the pair of instructions at C(PPR.IC)+1 either a specified number of times or until a specified termination condition is met.

MODIFICATIONS: None

INDICATORS: (Indicators not listed are not affected)

Tally runoff If C(X0)_{0,7} = 0 at termination, then ON; otherwise, OFF

All other indicators None affected. However, the execution of the repeated instructions may affect indicators.

NOTES: The rpd instruction must be located in an odd main memory location except when accessed via the xec or xed instructions, in which case the xec or xed instruction must itself be in an odd main memory location.

Both repeated instructions must use R or RI modifiers and only X1, X2, ..., X7 are permitted. For the purposes of this description, the even repeated instruction shall use X-even and the odd repeated instruction shall use X-odd. X-even and X-odd may be the same register.

If C = 1, then C(rpd instruction word)_{0,17} -> C(X0); otherwise, C(X0) is unchanged prior to execution.

The termination condition and tally fields of C(X0) control the repetition of the instruction pair. An initial tally of zero is interpreted as 256.

The repetition cycle consists of the following steps:

- a. Execute the pair of repeated instructions
- b. C(X0)_{0,7} - 1 -> C(X0)_{0,7}
Modify C(X-even) and C(X-odd) as described below.

REPEAT

- c. If $C(XO)_{0,7} = 0$, then set the tally runout indicator ON and terminate.
- d. If a terminate condition has been met, then set the tally runout indicator OFF and terminate.
- e. Go to step a.

If a fault occurs during the execution of the instruction pair, the repetition loop is terminated and control passes to the instruction pair associated with the fault according to the conditions for the fault. $C(XO)$, $C(X\text{-even})$, and $C(X\text{-odd})$ are not updated for the repetition cycle in which the fault occurs. Note in particular that certain faults occurring during execution of the even instruction preclude the execution of the odd instruction for the faulting repetition cycle.

EIS multiword instructions cannot be repeated. All other instructions may be repeated except as noted for individual instructions or those that explicitly alter $C(XO)$.

The computed addresses, $y\text{-even}$ and $y\text{-odd}$, of the operands (in the case of R modification) or indirect words (in the case of RI modification) are determined as follows:

For the first execution of the repeated instruction pair:

$$C(C(\text{PPR.IC})+1)_{0,17} + C(X\text{-even}) \rightarrow y\text{-even},$$

$$y\text{-even} \rightarrow C(X\text{-even})$$

$$C(C(\text{PPR.IC})+2)_{0,17} + C(X\text{-odd}) \rightarrow y\text{-odd},$$

$$y\text{-odd} \rightarrow C(X\text{-odd})$$

For all successive executions of the repeated instruction pair:

if $C(XO)_8 = 1$, then $C(X\text{-even}) + \text{Delta} \rightarrow y\text{-even}$,
 $y\text{-even} \rightarrow C(X\text{-even})$;
 otherwise, $C(X\text{-even}) \rightarrow y\text{-even}$

if $C(XO)_9 = 1$, then $C(X\text{-odd}) + \text{Delta} \rightarrow y\text{-odd}$,
 $y\text{-odd} \rightarrow C(X\text{-odd})$;
 otherwise, $C(X\text{-odd}) \rightarrow y\text{-odd}$

$C(XO)_{8,9}$ correspond to control bits A and B, respectively, of the rpd instruction word.

In the case of RI modification, only one indirect reference is made per repeated execution. The TAG field of the indirect word is not interpreted. The indirect word is treated as though it had R modification with $R = N$.

The bit configuration in $C(XO)_{11,17}$ defines the conditions for which the repetition loop is terminated. The terminate conditions are examined at the completion of execution of the odd instruction. If more than one condition is specified, the repeat terminates if any of the specified conditions are met.

- Bit 17 = 0 Ignore all overflows. Do not set the overflow indicator and inhibit the overflow fault.
- Bit 17 = 1 Process overflows. If the overflow mask indicator is ON, then set the overflow indicator and terminate; otherwise, cause an overflow fault.
- Bit 16 = 1 Terminate if the carry indicator is OFF.
- Bit 15 = 1 Terminate if the carry indicator is ON.
- Bit 14 = 1 Terminate if the negative indicator is OFF.
- Bit 13 = 1 Terminate if the negative indicator is ON.
- Bit 12 = 1 Terminate if the zero indicator is OFF.
- Bit 11 = 1 Terminate if the zero indicator is ON.

At the time of termination:

$C(X)_{0,7}$ contain the tally residue; that is, the number of repeats remaining until a tally runout would have occurred.

If the rpd instruction is interrupted (by any fault) before termination, the tally runout indicator is OFF.

$C(X\text{-even})$ and $C(X\text{-odd})$ contain the computed addresses of the next operands or indirect words that would have been used had the repetition loop not terminated.

Attempted repetition with the rpt, rpd, or rpl instructions causes an illegal procedure fault.

REPEAT

rpl	Repeat Link	500 (0)
-----	-------------	---------

FORMAT:

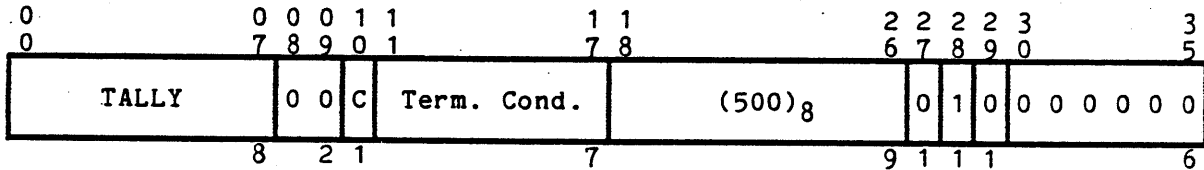

Figure 4-10. Repeat Link (rpl) Instruction Word Format

SUMMARY: Execute the instruction at C(PPR.IC)+1 either a specified number of times or until a specified termination condition is met.

MODIFICATIONS: None

INDICATORS: (Indicators not listed are not affected)

Tally runout If C(X0)_{0,7} = 0 or link address C(Y)_{0,17} = 0 at termination, then ON; otherwise OFF

All other indicators None affected. However, the execution of the repeated instruction may affect indicators.

NOTES: The repeated instruction must use an R modifier and only X1, X2, ..., X7 are permitted. For the purposes of this description, the repeated instruction shall use Xn.

If C = 1, then C(rpl instruction word)_{0,17} → C(X0); otherwise, C(X0) is unchanged prior to execution.

The termination condition and tally fields of C(X0) control the repetition of the instruction. An initial tally of zero is interpreted as 256.

The repetition cycle consists of the following steps:

- a. Execute the repeated instruction
- b. C(X0)_{0,7} - 1 → C(X0)_{0,7}
Modify C(Xn) as described below.
- c. If C(X0)_{0,7} = 0 or C(Y)_{0,17} = 0, then set the tally runout indicator ON and terminate.
- d. If a terminate condition has been met, then set the tally runout indicator OFF and terminate.
- e. Go to step a.

If a fault occurs during the execution of the instruction, the repetition loop is terminated and control passes to the instruction pair associated with the fault according to the conditions for the fault. $C(X_0)$ and $C(X_n)$ are not updated for the repetition cycle in which the fault occurs.

EIS multiword instructions cannot be repeated. All other instructions may be repeated except as noted for individual instructions or those that explicitly alter $C(X_0)$ or explicitly alter the link address, $C(Y)_{0,17}$.

The computed address, y , of the operand is determined as follows:

For the first execution of the repeated instruction:

$$C(C(PPR.IC)+1)_{0,17} + C(X_n) \rightarrow y, y \rightarrow C(X_n)$$

For all successive executions of the repeated instruction:

$$C(X_n) \rightarrow y$$

if $C(y)_{0,17} \neq 0$, then $C(y)_{0,17} \rightarrow C(X_n)$;
otherwise, no change to $C(X_n)$

$C(Y)_{0,17}$ is known as the link address and is the computed address of the next entry in a threaded list of operands to be referenced by the repeated instruction.

The operand is formed as:

$$(00\dots0)_{0,17} \parallel C(Y)_{18,p}$$

where p is 35 for single precision operands and 71 for double precision operands.

The bit configuration in $C(X_0)_{11,17}$ and the link address, $C(Y)_{0,17}$, define the conditions for which the repetition loop is terminated. The terminate conditions are examined at the completion of execution of the instruction. If more than one condition is specified, the repeat terminates if any of the specified conditions are met.

$C(Y)_{0,17} = 0$ Set the tally runout indicator ON and terminate.

Bit 17 = 0 Ignore all overflows. Do not set the overflow indicator and inhibit the overflow fault.

Bit 17 = 1 Process overflows. If the overflow mask indicator is ON, then set the overflow indicator and terminate; otherwise, cause an overflow fault.

Bit 16 = 1 Terminate if the carry indicator is OFF.

Bit 15 = 1 Terminate if the carry indicator is ON.

Bit 14 = 1 Terminate if the negative indicator is OFF.

Bit 13 = 1 Terminate if the negative indicator is ON.

Bit 12 = 1 Terminate if the zero indicator is OFF.

REPEAT

Bit 11 = 1 Terminate if the zero indicator is ON.

At the time of termination:

$C(X0)_{0,7}$ contain the tally residue; that is, the number of repeats remaining until a tally runout would have occurred.

If the rpt instruction is interrupted (by any fault) before termination, the tally runout indicator is OFF.

$C(Xn)$ contain the last link address, that is, the computed address of the list word containing the last operand and the next link address.

Attempted repetition with the rpt, rpd, or rpl instructions causes an illegal procedure fault.

rpt	Repeat	520 (0)
-----	--------	---------

FORMAT:

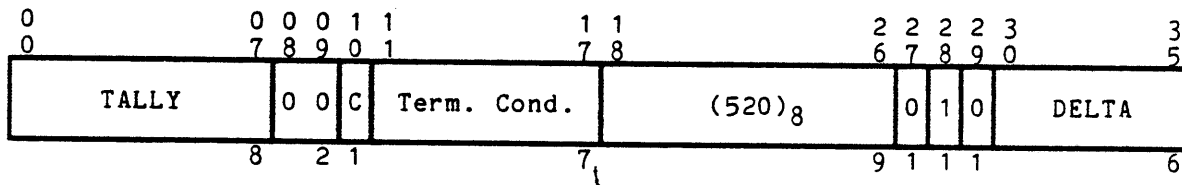

Figure 4-11. Repeat (rpt) Instruction Word Format

SUMMARY: Execute the instruction at $C(PPR.IC)+1$ either a specified number of times or until a specified termination condition is met.

MODIFICATIONS: None

INDICATORS: (Indicators not listed are not affected)

Tally runout If $C(X0)_{0,7} = 0$ at termination, then ON; otherwise, OFF

All other indicators None affected. However, the execution of the repeated instruction may affect indicators.

NOTES: The repeated instruction must use an R or RI modifier and only X1, X2, ..., X7 are permitted. For the purposes of this description, the repeated instruction shall use Xn.

If $C = 1$, then $C(\text{rpt instruction word})_{0,17} \rightarrow C(X0)$; otherwise, $C(X0)$ unchanged prior to execution.

The termination condition and tally fields of C(X0) control the repetition of the instruction. An initial tally of zero is interpreted as 256.

The repetition cycle consists of the following steps:

- a. Execute the repeated instruction
- b. $C(X0)_{0,7} - 1 \rightarrow C(X0)_{0,7}$
Modify C(Xn) as described below
- c. If $C(X0)_{0,7} = 0$, then set the tally runout indicator ON and terminate
- d. If a terminate condition has been met, then set the tally runout indicator OFF and terminate
- e. Go to step a

If a fault occurs during the execution of the instruction, the repetition loop is terminated and control passes to the instruction pair associated with the fault according to the conditions for the fault. C(X0) and C(Xn) are not updated for the repetition cycle in which the fault occurs.

EIS multiword instructions cannot be repeated. All other instructions may be repeated except as noted for individual instructions or those that explicitly alter C(X0) or explicitly alter the instruction pair containing the repeated instruction.

The computed address, y, of the operand (in the case of R modification) or indirect word (in the case of RI modification) is determined as follows:

For the first execution of the repeated instruction:

$$C(C(PPR.IC)+1)_{0,17} + C(Xn) \rightarrow y, y \rightarrow C(Xn)$$

For all successive executions of the repeated instruction:

$$C(Xn) + \Delta \rightarrow y, y \rightarrow C(Xn);$$

In the case of RI modification, only one indirect reference is made per repeated execution. The TAG field of the indirect word is not interpreted. The indirect word is treated as though it had R modification with $R = N$.

The bit configuration in $C(X0)_{11,17}$ defines the conditions for which the repetition loop is terminated. The terminate conditions are examined at the completion of execution of the instruction. If more than one condition is specified, the repeat terminates if any of the specified conditions are met.

Bit 17 = 0 Ignore all overflows. Do not set the overflow indicator and inhibit the overflow fault.

Bit 17 = 1 Process overflows. If the overflow mask indicator is ON, then set the overflow

REPEAT

indicator and terminate; otherwise, cause an overflow fault.

- Bit 16 = 1 Terminate if the carry indicator is OFF.
- Bit 15 = 1 Terminate if the carry indicator is ON.
- Bit 14 = 1 Terminate if the negative indicator is OFF.
- Bit 13 = 1 Terminate if the negative indicator is ON.
- Bit 12 = 1 Terminate if the zero indicator is OFF.
- Bit 11 = 1 Terminate if the zero indicator is ON.

At the time of termination:

$C(X0)_{0,7}$ contain the tally residue; that is, the number of repeats remaining until a tally runout would have occurred.

If the rpt instruction is interrupted (by any fault) before termination, the tally runout indicator is OFF.

$C(Xn)$ contain the computed address of the next operand or indirect word that would have been used had the repetition loop not terminated.

Attempted repetition with the rpt, rpd, or rpl instructions causes an illegal procedure fault.

Ring Alarm Register

sra	Store Ring Alarm	754 (1)
-----	------------------	---------

FORMAT: Basic instruction format (see Figure 4-1).

SUMMARY: 00...0 → C(Y)_{0,32}
C(RALR) → C(Y)_{33,35}

MODIFICATIONS: All except du, dl, ci, sc, scr

INDICATORS: None affected

NOTES: Attempted execution in BAR mode causes an illegal procedure fault.
Attempted repetition with the rpt, rpd, or rpl instructions causes an illegal procedure fault.

STORE BASE ADDRESS REGISTER

Store Base Address Register

sbar	Store Base Address Register	550 (0)
------	-----------------------------	---------

FORMAT: Basic instruction format (see Figure 4-1).

SUMMARY: $C(\text{BAR}) \rightarrow C(Y)_{0,17}$

MODIFICATIONS: All except du, dl, ci, sc, scr

INDICATORS: None affected

Translation

bcd	Binary to Binary-Coded-Decimal	505 (0)
-----	--------------------------------	---------

FORMAT: Basic instruction format (see Figure 4-1).

SUMMARY: Shift C(A) left three positions
 $|C(A)| / C(Y) \rightarrow$ 4-bit quotient plus remainder
 Shift C(Q) left six positions
 4-bit quotient $\rightarrow C(Q)_{32,35}$
 remainder $\rightarrow C(A)$

MODIFICATIONS: All except ci, sc, scr

INDICATORS: (Indicators not listed are not affected)

Zero If C(A) = 0, then ON; otherwise OFF

Negative If C(A)₀ = 1 before execution, then ON; otherwise OFF

NOTES: The bcd instruction carries out one step in an algorithm for the conversion of a binary number to a string of Binary-Coded-Decimal (BCD) digits. The algorithm requires the repeated short division of the binary number or last remainder by a set of constants $C_i = 8^{*i} \times 10^{*(n-i)}$ for $i = 1, 2, \dots, n$ with n being defined by:

$$10^{*(n-1)} \leq \text{[binary number]} \leq 10^{*n} - 1.$$

The values in the table that follows are the conversion constants to be used with the bcd instruction. Each vertical column represents the set of constants to be used depending on the initial value of the binary number to be converted. The instruction is executed once per digit while traversing the appropriate column from top to bottom.

An alternate use of the table for conversion involves the use of the constants in the row corresponding to conversion step 1. If, after each execution, the contents of the accumulator are shifted right 3 positions, the constants in the first row, starting at the appropriate column, may be used while traversing the row from left to right.

Because there is a limit on range, a full 36-bit word cannot be converted. The largest binary number that may be converted correctly is $2^{*33} - 1$ yielding ten decimal digits.

TRANSLATION

Attempted repetition with the rpl instruction causes an illegal procedure fault.

Step	For $10^{n-1} \leq C(A) \leq 10^n - 1$ and $n =$									
	<u>10</u>	<u>9</u>	<u>8</u>	<u>7</u>	<u>6</u>	<u>5</u>	<u>4</u>	<u>3</u>	<u>2</u>	<u>1</u>
1	8000000000	800000000	80000000	8000000	800000	80000	8000	800	80	8
2	6400000000	640000000	64000000	6400000	640000	64000	6400	640	64	64
3	5120000000	512000000	51200000	5120000	512000	51200	5120	512	512	
4	4096000000	409600000	40960000	4096000	409600	40960	4096	4096		
5	3276800000	327680000	32768000	3276800	327680	32768	32768			
6	2621440000	262144000	26214400	2621440	262144	262144				
7	2097152000	209715200	20971520	2097152	2097152					
8	1677721600	167772160	16777216	16777216						
9	1342177280	134217728								
10	1073741824									

gtb	Gray to Binary	774 (0)
-----	----------------	---------

FORMAT: Basic instruction format (see Figure 4-1).

SUMMARY: C(A) is converted from Gray Code to a 36-bit binary number

MODIFICATIONS: None

INDICATORS: (Indicators not listed are not affected)

Zero If C(A) = 0, then ON; otherwise OFF

Negative If C(A)₀ = 1, then ON; otherwise OFF

NOTES: This conversion is defined by the following algorithm:

$$C(A)_0 \rightarrow C(A)_0$$

$$C(A)_i \oplus C(A)_{i-1} \rightarrow C(A)_i \text{ for } i = 1, 2, \dots, 35$$

Attempted repetition with the rpl instruction causes an illegal procedure fault.

REGISTER LOAD

lbar	Load Base Address Register	230 (0)
------	----------------------------	---------

FORMAT: Basic instruction format (see Figure 4-1).

SUMMARY: $C(Y)_{0,17} \rightarrow C(\text{BAR})$

MODIFICATIONS All except ci, sc, scr

INDICATORS: None affected

NOTES: Attempted repetition with the rpt, rpd, or rpl instructions causes an illegal procedure fault.

Attempted execution in BAR mode causes a illegal procedure fault.

PRIVILEGED INSTRUCTIONS

Privileged - Register Load

lcpr	Load Central Processor Register	674 (0)
------	---------------------------------	---------

FORMAT: Basic instruction format (see Figure 4-1).

SUMMARY: Load selected register as noted

MODIFICATIONS: None. The instruction word TAG field is used for register selection as follows:

C(TAG) Data and Register(s)

02 C(Y) -> C(cache mode register)

04 C(Y) -> C(mode register)

03 DPS/L68 processors:
00...0 -> C(CU, OU, DU, and APU history register)_{0,71}

DPS 8M processors:
00...0 -> C(CU, OU/DU, APU #1 and APU #2 history register)_{0,71}

07 DPS/L68 processors:
11...1 -> C(CU, OU, DU, and APU history register)_{0,71}

DPS 8M processors:
11...1 -> C(CU, OU/DU, APU #1 and APU #2 history register)_{0,71}

INDICATORS: None affected

NOTES: See Section 3 for descriptions and use of the various registers.

PRIVILEGED - REGISTER LOAD

For TAG values 03 and 07, the history register loaded is selected by the current value of a cyclic counter for each unit. All four cyclic counters are advanced by one count for each execution of the instruction.

Use of TAG values other than those defined above causes an illegal procedure fault.

Attempted execution in normal or BAR modes causes a illegal procedure fault.

Attempted repetition with the rpt, rpd, or rpl instructions causes an illegal procedure fault.

ldbr	Load Descriptor Segment Base Register	232 (0)
------	---------------------------------------	---------

FORMAT: Basic instruction format (see Figure 4-1).

SUMMARY: If SDWAM is enabled, then

0 -> C(SDWAM(i).FULL) for i = 0, 1, ..., 15

i -> C(SDWAM(i).USE) for i = 0, 1, ..., 15

If PTWAM is enabled, then

0 -> C(PTWAM(i).FULL) for i = 0, 1, ..., 15

i -> C(PTWAM(i).USE) for i = 0, 1, ..., 15

If cache is enabled, reset all cache column and level full flags

C(Y-pair)_{0,23} -> C(DSBR.ADDR)

C(Y-pair)_{37,50} -> C(DSBR.BOUND)

C(Y-pair)₅₅ -> C(DSBR.U)

C(Y-pair)_{60,71} -> C(DSBR.STACK)

MODIFICATIONS: All except du, dl, ci, sc, scr

INDICATORS: None affected

NOTES: The associative memories and cache are cleared (full indicators reset) if they are enabled.

See Section 3 and Section 5 for descriptions and use of the SDWAM, PTWAM, and DSBR.

Attempted execution in normal or BAR modes causes an illegal procedure fault.

Attempted repetition with the rpt, rpd, or rpl instructions causes an illegal procedure fault.

ldt	Load Timer Register	637 (0)
-----	---------------------	---------

FORMAT: Basic instruction format (see Figure 4-1).

SUMMARY: $C(Y)_{0,26} \rightarrow C(TR)$

MODIFICATIONS: All except ci, sc, scr

INDICATORS: None Affected

NOTES: Attempted execution in normal or BAR modes causes a illegal procedure fault.

Attempted repetition with the rpt, rpd, or rpl instructions causes an illegal procedure fault.

lptp	Load Page Table Pointers	257 (1)
------	--------------------------	---------

FORMAT: Basic instruction format (see Figure 4-1).

SUMMARY: For $i = 0, 1, \dots, 15$

$m = C(PTWAM(i).USE)$

$C(Y\text{-block}16+m)_{0,14} \rightarrow C(PTWAM(m).POINTER)$

$C(Y\text{-block}16+m)_{15,26} \rightarrow C(PTWAM(m).PAGE)$

$C(Y\text{-block}16+m)_{27} \rightarrow C(PTWAM(m).F)$

MODIFICATIONS: All except du, dl, ci, sc, scr

INDICATORS: None affected

NOTES: The associative memory is ignored (forced to "no match") during address preparation.

See Section 3 and Section 5 for description and use of the PTWAM.

This instruction is not available on the DPS 8M processor and attempted execution on a DPS 8M processor causes an illegal procedure fault.

Attempted execution in normal or BAR modes causes an illegal procedure fault.

PRIVILEGED - REGISTER LOAD

Attempted repetition with the rpt, rpd, or rpl instructions causes an illegal procedure fault.

lptr	Load Page Table Registers	173 (1)
------	---------------------------	---------

FORMAT: Basic instruction format (see Figure 4-1).

SUMMARY: For $i = 0, 1, \dots, 15$
 $m = C(\text{PTWAM}(i).\text{USE})$
 $C(\text{Y-block}16+m)_{0,17} \rightarrow C(\text{PTWAM}(m).\text{ADDR})$
 $C(\text{Y-block}16+m)_{29} \rightarrow C(\text{PTWAM}(m).\text{M})$

MODIFICATIONS: All except du, dl, ci, sc, scr

INDICATORS: None affected

NOTES: The associative memory is ignored (forced to "no match") during address preparation.
 See Section 3 and Section 5 for description and use of the PTWAM.
 Attempted execution in normal or BAR modes causes an illegal procedure fault.
 This instruction is not available on the DPS 8M processor and attempted execution on a DPS 8M processor produces an illegal procedure fault.
 Attempted repetition with the rpt, rpd, or rpl instructions causes an illegal procedure fault.

lra	Load Ring Alarm Register	774 (1)
-----	--------------------------	---------

FORMAT: Basic instruction format (see Figure 4-1).

SUMMARY: $C(\text{Y})_{33,35} \rightarrow C(\text{RALR})$

MODIFICATIONS: All except du, dl, ci, sc, scr

INDICATORS: None affected

NOTES: Attempted execution in normal or BAR modes causes an illegal procedure fault.
 Attempted repetition with the rpt, rpd, or rpl instructions causes an illegal procedure fault.

lsdp	Load Segment Descriptor Pointers	257 (0)
------	----------------------------------	---------

FORMAT: Basic instruction format (see Figure 4-1).

SUMMARY: For $i = 0, 1, \dots, 15$
 $m = C(\text{SDWAM}(i).\text{USE})$
 $C(\text{Y-block}16+m)_{0,14} \rightarrow C(\text{SDWAM}(m).\text{POINTER})$
 $C(\text{Y-block}16+m)_{17} \rightarrow C(\text{SDWAM}(m).\text{P})$

MODIFICATIONS: All except du, dl, ci, sc, scr

INDICATORS: None affected

NOTES: The associative memory is ignored (forced to "no match") during address preparation.
 See Section 3 and Section 5 for description and use of the SDWAM.
 This instruction is not available on the DPS 8M processor and attempted execution on a DPS 8M processor produces an illegal procedure fault.
 Attempted execution in normal or BAR modes causes an illegal procedure fault.
 Attempted repetition with the rpt, rpd, or rpl instructions causes an illegal procedure fault.

lsdr	Load Segment Descriptor Registers	232 (1)
------	-----------------------------------	---------

FORMAT: Basic instruction format (see Figure 4-1).

SUMMARY: For $i = 0, 1, \dots, 15$
 $m = C(\text{SDWAM}(i).\text{USE})$
 $\text{Y-pair} = \text{Y-block}32 + 2m$
 $C(\text{Y-pair})_{0,23} \rightarrow C(\text{SDWAM}(m).\text{ADR})$
 $C(\text{Y-pair})_{24,32} \rightarrow C(\text{SDWAM}(m).\text{R1, R2, R3})$
 $C(\text{Y-pair})_{37,50} \rightarrow C(\text{SDWAM}(m).\text{BOUND})$
 $C(\text{Y-pair})_{52,57} \rightarrow C(\text{SDWAM}(m).\text{R, E, W, P, U, G, C})$
 $C(\text{Y-pair})_{58,71} \rightarrow C(\text{SDWAM}(m).\text{CL})$

PRIVILEGED - REGISTER LOAD

MODIFICATIONS: All except du, dl, ci, sc, scr

INDICATORS: None Affected

NOTES: The associative memory is ignored (forced to "no-match") during address preparation.

See Section 3 and Section 5 for description and use of the SDWAM.

This instruction is not available on the DPS 8M processor and attempted execution on a DPS 8M processor produces an illegal procedure fault.

Attempted execution in normal or BAR modes causes an illegal procedure fault.

Attempted repetition with the rpt, rpd, or rpl instructions causes an illegal procedure fault.

rcu	Restore Control Unit	613 (0)
-----	----------------------	---------

FORMAT: Basic instruction format (see Figure 4-1).

SUMMARY: C(Y-block8) words 0 to 7 -> (control unit data)

MODIFICATIONS: All except du, dl, ci, sc, scr

INDICATORS: None affected

NOTES: See Section 3 for description and use of control unit data.

Attempted execution in normal or BAR modes causes an illegal procedure fault.

Attempted repetition with the rpt, rpd, or rpl instructions causes an illegal procedure fault.

Privileged - Register Store

scpr	Store Central Processor Register	452 (0)
------	----------------------------------	---------

FORMAT: Basic instruction format (see Figure 4-1).

SUMMARY: Store selected register as noted

MODIFICATIONS: None. The instruction word TAG field is used for register selection word as follows:

<u>C(TAG)</u>	<u>MEANING</u>
00	DPS/L68 processor: C(APU history register) -> C(Y-pair)
	DPS 8M processor: C(APU history register #1) -> C(Y-pair)
01	C(fault register) -> C(Y-pair) _{0,35} 00...0 -> C(Y-pair) _{36,71}
06	C(mode register) -> C(Y-pair) _{0,35} C(cache mode register) -> C(Y-pair) _{36,71}
10	DPS/L68 processor: C(DU history register) -> C(Y-pair)
	DPS 8M processor: C(APU history register #2) -> C(Y-pair)
20	C(CU history register) -> C(Y-pair)
40	DPS/L68 processor: C(OU history register) -> C(Y-pair)
	DPS 8M processor: C(OU/DU history register) -> C(Y-pair)

INDICATORS: None affected

NOTES: See Section 3 for description and use of the various registers.
The TAG field values shown are octal.

For TAG values 00, 10, 20, and 40, the history register stored is selected by the current value of a cyclic counter for each unit. The individual cyclic counters are advanced by one count for each execution of the instruction.

The use of TAG values other than those defined above causes an illegal procedure fault.

Attempted execution in normal or BAR modes causes an illegal procedure fault.

Attempted repetition with the rpt, rpd, or rpl instructions causes an illegal procedure fault.

PRIVILEGED - REGISTER STORE

scu	Store Control Unit	657 (0)
-----	--------------------	---------

FORMAT: Basic instruction format (see Figure 4-1).

SUMMARY: (control unit data) -> C(Y-block8)

MODIFICATIONS: All except du, dl, ci, sc, scr

INDICATORS: None affected

NOTES: See Section 3 for description and use of control unit data.

The scu instruction safe-stores control information required to service a fault or interrupt. The control unit data is not, in general, valid at any time except when safe-stored by the first of the pair of instructions associated with the fault or interrupt.

Attempted execution in normal or BAR modes causes an illegal procedure fault.

Attempted repetition with the rpt, rpd, or rpl instructions causes an illegal procedure fault.

sdbr	Store Descriptor Segment Base Register	154 (0)
------	--	---------

FORMAT: Basic instruction format (see Figure 4-1).

SUMMARY: C(DSBR.ADDR) -> C(Y-pair)_{0,23}
 00...0 -> C(Y-pair)_{24,36}
 C(DSBR.BOUND) -> C(Y-pair)_{37,50}
 0000 -> C(Y-pair)_{51,54}
 C(DSBR.U) -> C(Y-pair)₅₅
 000 -> C(Y-pair)_{56,59}
 C(DSBR.STACK) -> C(Y-pair)_{60,71}

MODIFICATIONS: All except du, dl, ci, sc, scr

INDICATORS: None affected

NOTES: C(DSBR) are unchanged.

See Section 3 and Section 5 for description and use of the DSBR.

Attempted execution in normal or BAR modes causes an illegal procedure fault.

Attempted repetition with the rpt, rpd, or rpl instructions causes an illegal procedure fault.

sptp	Store Page Table Pointers	557 (1)
------	---------------------------	---------

FORMAT: Basic instruction format (see Figure 4-1).

SUMMARY: DPS/L68 processors:

For $i = 0, 1, \dots, 15$

$C(\text{PTWAM}(i).\text{POINTER}) \rightarrow C(\text{Y-block}16+i)_{0,14}$

$C(\text{PTWAM}(i).\text{PAGE}) \rightarrow C(\text{Y-block}16+i)_{15,26}$

$C(\text{PTWAM}(i).\text{F}) \rightarrow C(\text{Y-block}16+i)_{27}$

$0000 \rightarrow C(\text{Y-block}16+i)_{8,31}$

$C(\text{PTWAM}(i).\text{USE}) \rightarrow C(\text{Y-block}16+i)_{32,35}$

DPS 8M processors:

This instruction stores 16 words from the selected level (j) of the directory of the Page Table Word associative memory. There are four levels.

level j is selected by $C(\text{TPR.CA})_{12,13}$

For $i = 0, 1, \dots, 15$

$C(\text{PTWAM}(i,j).\text{POINTER}) \rightarrow C(\text{Y-block}16+i)_{0,14}$

$C(\text{PTWAM}(i,j).\text{PAGENO}) \rightarrow C(\text{Y-block}16+i)_{15,22}$

$0000 \rightarrow C(\text{Y-block}16+i)_{23,26}$

$C(\text{PTWAM}(i,j).\text{F}) \rightarrow C(\text{Y-block}16+i)_{27}$

$00 \rightarrow C(\text{Y-block}16+i)_{28,29}$

$C(\text{PTWAM}(i,j).\text{LRU}) \rightarrow C(\text{Y-block}16+i)_{30,35}$

MODIFICATIONS: All except du, dl, ci, sc, scr

INDICATORS: None affected

NOTES: The contents of the associative memory remain unchanged.

The associative memory is ignored (forced to "no match") during address preparation.

PRIVILEGED - REGISTER STORE

See Section 3 and Section 5 for description and use of the PTWAM.

Attempted execution in normal or BAR modes causes an illegal procedure fault.

Attempted repetition with the rpt, rpd, or rpl instructions causes an illegal procedure fault.

sptr	Store Page Table Registers	154 (1)
------	----------------------------	---------

FORMAT: Basic instruction format (see Figure 4-1).

SUMMARY: DPS/L68 processors:

For $i = 0, 1, \dots, 15$

$C(\text{PTWAM}(i).\text{ADDR}) \rightarrow C(\text{Y-block}16+i)_{0,17}$

$00\dots0 \rightarrow C(\text{Y-block}16+i)_{18,28}$

$C(\text{PTWAM}(i).\text{M}) \rightarrow C(\text{Y-block}16+i)_{29}$

$00\dots0 \rightarrow C(\text{Y-block}16+i)_{30,35}$

DPS 8M processors:

This instruction stores 16 words from the selected level (j) of the contents of the Page Table Word associative memory. There are four levels.

Level j is selected by $C(\text{TPR.CA})_{12,13}$

For $i = 0, 1, \dots, 15$

$C(\text{PTWAM}(i,j).\text{PAGE ADDR}) \rightarrow C(\text{Y-block}16+i)_{0,13}$

$00\dots0 \rightarrow C(\text{Y-block}16+i)_{14,28}$

$C(\text{PTWAM}(i,j).\text{M}) \rightarrow C(\text{Y-block}16+i)_{29}$

$000000 \rightarrow C(\text{Y-block}16+i)_{30,35}$

MODIFICATIONS: All except du, dl, ci, sc, scr

INDICATORS: None affected

NOTES: The contents of the associative memory are unchanged.

The associative memory is ignored (forced to "no match") during address preparation.

See Section 3 and Section 5 for description and use of the PTWAM.

Attempted execution in normal or BAR modes causes an illegal procedure fault.

Attempted repetition with the rpt, rpd, or rpl instructions causes an illegal procedure fault.

ssdp	Store Segment Descriptor Pointers	557 (0)
------	-----------------------------------	---------

FORMAT: Basic instruction format (see Figure 4-1).

SUMMARY: DPS/L68 processors:

For $i = 0, 1, \dots, 15$

$C(\text{SDWAM}(i).\text{POINTER}) \rightarrow C(\text{Y-block}16+i)_{0,14}$

$00\dots0 \rightarrow C(\text{Y-block}16+i)_{15,26}$

$C(\text{SDWAM}(i).F) \rightarrow C(\text{Y-block}16+i)_{27}$

$0000 \rightarrow C(\text{Y-block}16+i)_{28,31}$

$C(\text{SDWAM}(i).\text{USE}) \rightarrow C(\text{Y-block}16+i)_{32,35}$

DPS 8M processors:

This instruction stores 16 words from the selected level (j) of the directory of the Segment Descriptor Word associative memory. There are four levels.

level j is selected by $C(\text{TPR}.A)_{12,13}$

For $i = 0, 1, \dots, 15$

$C(\text{SDWAM}(i,j).\text{POINTER}) \rightarrow C(\text{Y-block}16+i)_{0,14}$

$00\dots0 \rightarrow C(\text{Y-block}16+i)_{15,26}$

$C(\text{SDWAM}(i,j).F) \rightarrow C(\text{Y-block}16+i)_{27}$

$00 \rightarrow C(\text{Y-block}16+i)_{28,29}$

$C(\text{SDWAM}(i,j).\text{LRU}) \rightarrow C(\text{Y-block}16+i)_{30,35}$

MODIFICATIONS: All except du, dl, ci, sc, scr

INDICATORS: None affected

NOTES: The contents of the associative memory are unchanged.

The associative memory is ignored (forced to "no match") during address preparation.

See Section 3 and Section 5 for description and use of the SDWAM.

PRIVILEGED - REGISTER STORE

Attempted execution in normal or BAR modes causes an illegal procedure fault.

Attempted repetition with the rpt, rpd, or rpl instructions causes an illegal procedure fault.

ssdr	Store Segment Descriptor Registers	254 (1)
------	------------------------------------	---------

FORMAT: Basic instruction format (see Figure 4-1).

SUMMARY: DPS/L68 processors:

For $i = 0, 1, \dots, 15$

$Y\text{-pair} = Y\text{-block}_{32} + 2i$

$C(\text{SDWAM}(i).\text{ADDR}) \rightarrow C(Y\text{-pair})_{0,23}$

$C(\text{SDWAM}(i).R1, R2, R3) \rightarrow C(Y\text{-pair})_{24,32}$

$0000 \rightarrow C(Y\text{-pair})_{33,36}$

$C(\text{SDWAM}(i).\text{BOUND}) \rightarrow C(Y\text{-pair})_{37,50}$

$C(\text{SDWAM}(i).R, E, P, U, G, C) \rightarrow C(Y\text{-pair})_{51,57}$

$C(\text{SDWAM}(i).\text{CL}) \rightarrow C(Y\text{-pair})_{58,71}$

DPS 8M processors:

This instruction stores 16 double-words from the selected level (j) of the directory of the Segment Descriptor Word associative memory. There are four levels.

level j is selected by $C(\text{TPR.CA})_{11,12}$

For $i = 0, 1, \dots, 15$

$C(\text{SDWAM}(i,j).\text{ADDR}) \rightarrow (Y\text{-block}_{32+i})_{0,23}$

$C(\text{SDWAM}(i,j).R1, R2, R3) \rightarrow C(Y\text{-block}_{32+i})_{24,32}$

$000 \rightarrow C(Y\text{-block}_{32+i})_{33,35}$

$0 \rightarrow C(Y\text{-block}_{32+i})_{36}$

$C(\text{SDWAM}(i,j).\text{BOUND}) \rightarrow C(Y\text{-block}_{32+i})_{37,50}$

$C(\text{SDWAM}(i,j).R, E, W, P, U, G, C) \rightarrow C(Y\text{-block}_{32+i})_{51,57}$

$C(\text{SDWAM}(i,j).\text{CALL LIMIT}) \rightarrow C(Y\text{-block}_{32+i})_{58,71}$

MODIFICATIONS: All except du, dl, ci, sc, scr

INDICATORS: None affected

NOTES: The contents of the associative memory are unchanged.

PRIVILEGED - REGISTER STORE

The associative memory is ignored (forced to "no match") during address preparation.

See Section 3 and Section 5 for description and use of the SDWAM.

Attempted execution in normal or BAR modes causes an illegal procedure fault.

Attempted repetition with the rpt, rpd, or rpl instructions causes an illegal procedure fault.

PRIVILEGED - CLEAR ASSOCIATIVE MEMORY

Privileged - Clear Associative Memory

camp	Clear Associative Memory Pages	532 (1)
------	--------------------------------	---------

FORMAT: Basic instruction format (see Figure 4-1).

SUMMARY: DPS/L68 processors:

For $i = 0, 1, \dots, 15$

0 -> C(PWAM(i).F)

(i) -> C(PWAM(i).USE)

DPS 8M processors:

If the associative memory is enabled

0 -> C(PWAM.F)

C(PWAM.LRU) is initialized for all PWAM registers

MODIFICATIONS: All except du, dl, ci, sc, scr

INDICATORS: None affected

NOTES: DPS/L68 processors:

The full/empty bit of each PWAM register is set to 0, and the usage counters (PWAM.USE) are set to their pre-assigned values of 0 through 15. The remainder of C(PWAM(i)) is unchanged.

The execution of this instruction enables the PWAM if it is disabled and $C(TPR.CA)_{16,17} = 10$.

The execution of this instruction disables the PWAM if $C(TPR.CA)_{16,17} = 01$.

If $C(TPR.CA)_{15} = 1$, a selective clear of cache is executed. Any cache block for which the upper 14 bits of the directory entry equal $C(PWAM(i).ADDR)_{0,13}$ will have its full/empty bit set to empty.

DPS 8M processors:

The full/empty bit of cache PWAM register is set to zero and the LRU counters are initialized. The remainder of the contents of the registers are unchanged. If the associative memory is disabled, F and LRU are unchanged.

$C(TPR.CA)_{16,17}$ control disabling or enabling the associative memory. This may be done to either or both halves.

PRIVILEGED - CLEAR ASSOCIATIVE MEMORY

C(TPR.CA) _{13,14}	Selection
00	both halves
01	lower half, levels C & D
10	upper half, levels A & B
11	both halves

The selected portion of the associative memory is

-disabled if C(TPR.CA)_{16,17} = 01

-enabled if C(TPRCA)_{16,17} = 10

If the associative memory is disabled, the execution of two instructions are required to first enable and then clear it.

C(TPR.CA)₁₅ has no effect on the DPS 8M cache. On previous Multics processors this bit enabled selective cache clearing (see above).

All processors:

See Section 3 and Section 5 for description and use of the PTWAM.

Attempted execution in normal or BAR modes causes an illegal procedure fault.

Attempted repetition with the rpt, rpd, or rpl instructions causes an illegal procedure fault.

cams	Clear Associative Memory Segments	532 (0)
------	-----------------------------------	---------

FORMAT: Basic instruction format (see Figure 4-1).

SUMMARY: DPS/L68 processors:

For $i = 0, 1, \dots, 15$

0 -> C(SDWAM(i).F)

(i) -> C(SDWAM(i).USE)

DPS 8M processors:

If the associative memory is enabled

0 -> C(SDWAM.F)

C(SDWAM.LRU) is initialized for all PTWAM registers

MODIFICATIONS: All except du, dl, ci, sc, scr

INDICATORS: None affected

This page intentionally left blank.

NOTES:

DPS/L68 processors:

The full/empty bit of each SDWAM register is set to zero, and the usage counters (SDWAM.USE) are initialized to their pre-assigned values of 0 through 15. The remainder of C(SDWAM(i)) are unchanged.

The execution of this instruction enables the SDWAM if it is disabled and C(TPR.CA)_{16,17} = 10.

The execution of this instruction disables the SDWAM if C(TPR.CA)_{16,17} = 01.

The execution of this instruction sets the full/empty bits of all cache blocks to empty if C(TPR.CA)₁₅ = 1.

DPS 8M processors:

The full/empty bit of each SDWAM register is set to zero and the LRU counters are initialized. The remainder of the contents of the registers are unchanged. If the associative memory is disabled, F and LRU are unchanged.

C(TPR.CA)_{16,17} control disabling or enabling the associative memory. This may be done to either or both halves.

C(TPR.CA) _{13,14}	Selection
00	Both halves
01	Lower half levels C & D
10	Upper half, levels A & B
11	Both halves

The selected portion of the associative memory is

-disabled if C(TPR.CA)_{16,17} = 01

-enabled if C(TPR.CA)_{16,17} = 10

If the associative memory is disabled, the execution of two instructions are required to first enable and then clear it.

C(TPR.CA)₁₅ has no effect on the DPS 8M cache. On previous Multics processors this bit enabled a full cache clear (see above).

All processors:

See Section 3 and Section 5 for description and use of the SDWAM.

Attempted execution in normal or BAR modes causes an illegal procedure fault.

Attempted repetition with the rpt, rpd, or rpl instructions causes an illegal procedure fault.

PRIVILEGED - CONFIGURATION AND STATUS

Privileged - Configuration and Status

rmcm	Read Memory Controller Mask Register	233 (0)
------	--------------------------------------	---------

FORMAT: Basic instruction format (see Figure 4-1).

SUMMARY: For the selected system controller (see NOTES):
 If the processor has a mask register assigned, then
 C(assigned mask register) -> C(AQ)
 otherwise, 00...0 -> C(AQ)

MODIFICATIONS: All except du, dl, ci, sc, scr

INDICATORS: (Indicators not listed are not affected)

Zero If C(AQ) = 0, then ON; otherwise OFF

Negative If C(AQ)₀ = 1, then ON; otherwise OFF

NOTES: The contents of the mask register remain unchanged.

C(TPR.CA)_{0,2} (C(TPR.CA)_{1,2} for the DPS 8M processor) specify which processor port (i.e., which system controller) is used.

Attempted execution in normal or BAR modes causes an illegal procedure fault.

rscr	Read System Controller Register	413 (0)
------	---------------------------------	---------

FORMAT: Basic instruction format (see Figure 4-1).

SUMMARY: The final computed address, C(TPR.CA), is used to select a system controller and the function to be performed as follows:

<u>Effective Address</u>	<u>Function</u>
y0000x	C(system controller mode register) -> C(AQ)
y0001x	C(system controller configuration switches) -> C(AQ)
y0002x	C(mask register assigned to port 0) -> C(AQ)
y0012x	C(mask register assigned to port 1) -> C(AQ)

PRIVILEGED - CONFIGURATION AND STATUS

y0022x C(mask register assigned to port 2) -> C(AQ)
y0032x C(mask register assigned to port 3) -> C(AQ)
y0042x C(mask register assigned to port 4) -> C(AQ)
y0052x C(mask register assigned to port 5) -> C(AQ)
y0062x C(mask register assigned to port 6) -> C(AQ)
y0072x C(mask register assigned to port 7) -> C(AQ)
y0003x C(interrupt cells) -> C(AQ)
y0004x
or
y0005x C(calendar clock) -> C(AQ)
y0006x
or
y0007x C(store unit mode register) -> C(AQ)

where: y = value of C(TPR.CA)_{0,2} (C(TPR.CA)_{1,2} for the DPS 8M processor) used to select the system controller
x = any octal digit

MODIFICATIONS: All except du, dl, ci, sc, scr

INDICATORS: None affected

NOTES: See Section 3 for description and use of the various registers.
For computed addresses y0006x and y0007x, store unit selection is done by the normal address decoding function of the system controller.
Attempted execution in normal or BAR modes causes an illegal procedure fault.
Attempted repetition with the rpl instruction causes an illegal procedure fault.

rsw	Read Switches	231 (0)
-----	---------------	---------

FORMAT: Basic instruction format (see Figure 4-1).

SUMMARY: The final computed address, C(TPR.CA), is used to select certain processor switches whose settings are read into the A-register.

PRIVILEGED - CONFIGURATION AND STATUS

The switches selected are as follows:

<u>Effective</u> <u>Address</u>	<u>Function</u>
xxxxx0	C(data switches) -> C(A)
xxxxx1	C(configuration switches for ports A, B, C, D) -> C(A)
	DPS/L68 processors:
xxxxx2	00...0 -> C(A) _{0,5} C(fault base switches) -> C(A) _{6,12} 00...0 -> C(A) _{13,22} C(processor ID) _{23,33} -> C(A) _{23,33} C(processor number switches) -> C(A) _{34,35}
	DPS 8M processors:
	C(Port interface, Ports A-D) -> C(A) _{0,3} 01 -> C(A) _{4,5} C(Fault base switches) -> C(A) _{6,12} 1 -> C(A) ₁₃ 0000 -> C(A) _{14,17} 111 -> C(A) _{18,20} 00 -> C(A) _{21,22} 1 -> C(A) ₂₃ C(Processor mode sw) -> C(A) ₂₄ 1 -> C(A) ₂₅ 000 -> C(A) _{26,28} C(Processor speed) -> C(A) _{29,32} C(Processor number switches) -> C(A) _{33,35}
xxxxx3	C(configuration switches for ports E, F, G, H) -> C(A) (DPS/L68 processors only)
xxxxx4	00...0 -> C(A) _{0,12} C(port interlace and size switches) -> C(A) _{13,28} 00...0 -> C(A) _{29,35} (DPS/L68 processors only)

where: x = any octal digit

MODIFICATIONS: All, but none affect instruction execution

INDICATORS: (Indicators not listed are not affected)

Zero If C(A) = 0, then ON; otherwise OFF

Negative If C(A)₀ = 1, then ON; otherwise OFF

NOTES: See Section 3 for description and use of the switch data.

Attempted execution in normal or BAR modes causes an illegal procedure fault.

Attempted repetition with the rpt, rpd, or rpl instructions causes an illegal procedure fault.

Privileged - System Control

cioc	Connect I/O Channel	015 (0)
------	---------------------	---------

FORMAT: Basic instruction format (see Figure 4-1).

SUMMARY: The system controller addressed by Y (i.e., contains the word at Y) sends a connect signal to the port specified by C(Y)_{33,35}.

MODIFICATIONS: All except du, dl, ci, sc, scr

INDICATORS: None affected

NOTES: Attempted execution in normal or BAR modes causes an illegal procedure fault.

Attempted repetition with the rpt, rpd, or rpl instructions causes an illegal procedure fault.

smcm	Set Memory Controller Mask Register	553 (0)
------	-------------------------------------	---------

FORMAT: Basic instruction format (see Figure 4-1).

SUMMARY: For the selected system controller:

If the processor has a mask register assigned, then

C(AQ) -> C(assigned mask register)

otherwise a store fault (not control) occurs.

MODIFICATIONS: All except du, dl, ci, sc, scr

INDICATORS: None affected

NOTES: C(TPR.CA)_{0,2} (C(TPR.CA)_{1,2} on the DPS 8M processor) specify which processor port (i.e., which system controller) is used.

Attempted execution in normal or BAR modes causes an illegal procedure fault.

Attempted repetition with the rpl instruction causes an illegal procedure fault.

PRIVILEGED - SYSTEM CONTROL

If the SCU is a 4MW type SCU, the illegal action code 1000 (Not Control Port) is not used.

smic	Set Memory Controller Interrupt Cells	451 (0)
------	---------------------------------------	---------

FORMAT: Basic instruction format (see Figure 4-1).

SUMMARY: For $i = 0, 1, \dots, 15$ and $C(A)_{35} = 0$:
 if $C(A)_i = 1$, then set interrupt cell i ON
 For $i = 0, 1, \dots, 15$ and $C(A)_{35} = 1$:
 if $C(A)_i = 1$, then set interrupt cell $16+i$ ON

MODIFICATIONS: All except du, dl, ci, sc, scr

INDICATORS: None affected

NOTES: $C(TPR.CA)_{0,2}$ ($C(TPR.(A))_{1,2}$ on a DPS 8M processor) specify which processor port (i.e., which system controller) is used. If the processor has no assigned mask register in the selected system controller, a store fault (not control) occurs.

If the SCU is a 4MW type SCU, the illegal action code 1000 (Not Control Port) is not used.

Attempted execution in normal or BAR modes causes an illegal procedure fault.

sscr	Set System Controller Register	057 (0)
------	--------------------------------	---------

FORMAT: Basic instruction format (see Figure 4-1).

SUMMARY: The final computed address, $C(TPR.CA)$, is used to select a system controller and the function to be performed as follows:

<u>Effective Address</u>	<u>Function</u>
y0000x	$C(AQ) \rightarrow C(\text{system controller mode register})$
y0001x	Reserved
y0002x	$C(AQ) \rightarrow C(\text{mask register assigned to port 0})$
y0012x	$C(AQ) \rightarrow C(\text{mask register assigned to port 1})$
y0022x	$C(AQ) \rightarrow C(\text{mask register assigned to port 2})$
y0032x	$C(AQ) \rightarrow C(\text{mask register assigned to port 3})$
y0042x	$C(AQ) \rightarrow C(\text{mask register assigned to port 4})$

PRIVILEGED - SYSTEM CONTROL

y0052x C(AQ) -> C(mask register assigned to port 5)
y0062x C(AQ) -> C(mask register assigned to port 6)
y0072x C(AQ) -> C(mask register assigned to port 7)
y0003x C(AQ)_{0,15} -> C(interrupt cells 0-15)
C(AQ)_{36,51} -> C(interrupt cells 16-31)
y0004x C(AQ) -> (calendar clock)
or (for 4MW SCU only)
y0005x
y0006x C(AQ) -> C(store unit mode register)
or
y0007x

where: y = value of C(TPR.CA)_{0,2} (C(TPR.CA)_{1,2} on the DPS 8M processor) used to select the system controller

x = any octal digit

MODIFICATIONS: All except du, dl, ci, sc, scr

INDICATORS: None affected

NOTES: If the processor does not have a mask register assigned in the selected system controller a store fault (not control) occurs.

For computed addresses y0006x and y0007x, store unit selection is done by the normal address decoding function of the system controller.

See Section 3 for description and use of the various registers.

Attempted execution on normal or BAR modes causes an illegal procedure fault.

PRIVILEGED - MISCELLANEOUS

Privileged - Miscellaneous

absa	Absolute Address to A-Register	212 (0)
------	--------------------------------	---------

FORMAT: Basic instruction format (see Figure 4-1).

SUMMARY: Final main memory address, $Y \rightarrow C(A)_{0,23}$
 $00\dots0 \rightarrow C(A)_{24,35}$

MODIFICATIONS: All except du, dl, ci, sc, scr

INDICATORS: (Indicators not listed are not affected)

Zero If $C(A) = 0$, then ON; otherwise OFF

Negative If $C(A)_0 = 1$, then ON; otherwise OFF

NOTES: If the absa instruction is executed in absolute mode, $C(A)$ will be undefined.

Attempted execution in normal or BAR modes causes an illegal procedure fault.

Attempted repetition with the rpt, rpd, or rpl instructions causes an illegal procedure fault.

dis	Delay Until Interrupt Signal	616 (0)
-----	------------------------------	---------

FORMAT: Basic instruction format (see Figure 4-1).

SUMMARY: No operation takes place, and the processor does not continue with the next instruction; it waits for a external interrupt signal.

MODIFICATIONS: All, but none affect instruction execution

INDICATORS: None affected

NOTES: Attempted execution in normal or BAR modes causes an illegal procedure fault.

Attempted repetition with the rpt, rpd, or rpl instructions causes an illegal procedure fault.

EXTENDED INSTRUCTION SET (EIS)EIS - Address Register Load

<u>aarn</u>	Alphanumeric Descriptor to Address Register <u>n</u>	56 <u>n</u> (1)
-------------	--	-----------------

FORMAT: EIS single-word instruction format (see Figure 4-1).

SUMMARY: For $n = 0, 1, \dots, \text{or } 7$ as determined by operation code

$C(Y)_{0,17} \rightarrow C(\text{ARn.WORDNO})$

If $C(Y)_{21,22} = 00$ (TA code = 0), then

$C(Y)_{18,19} \rightarrow C(\text{ARn.CHAR})$

$0000 \rightarrow C(\text{ARn.BITNO})$

If $C(Y)_{21,22} = 01$ (TA code = 1), then

$(6 * C(Y)_{18,20}) / 9 \rightarrow C(\text{ARn.CHAR})$

$(6 * C(Y)_{18,20})_{\text{mod}9} \rightarrow C(\text{ARn.BITNO})$

If $C(Y)_{21,22} = 10$ (TA code = 2), then

$C(Y)_{18,20} / 2 \rightarrow C(\text{ARn.CHAR})$

$4 * (C(Y)_{18,20})_{\text{mod}2} + 1 \rightarrow C(\text{ARn.BITNO})$

MODIFICATIONS: All except du, dl, ci, sc, scr

INDICATORS: None affected.

NOTES: An alphanumeric descriptor is fetched from Y and $C(Y)_{21,22}$ (TA field) is examined to determine the data type described.

If TA = 0 (9-bit data), then $C(Y)_{18,19}$ goes to C(ARn.CHAR) and zeros fill C(ARn.BITNO).

If TA = 1 (6-bit data) or TA = 2 (4-bit data), $C(Y)_{18,20}$ is appropriately translated into an equivalent character and bit position that goes to C(ARn.CHAR) and C(ARn.BITNO).

If $C(Y)_{21,22} = 11$ (TA code = 3) an illegal procedure fault occurs.

If $C(Y)_{23} = 1$ an illegal procedure fault occurs.

If $C(Y)_{21,22} = 00$ (TA code = 0) and $C(Y)_{20} = 1$ an illegal procedure fault occurs.

EIS - ADDRESS REGISTER LOAD

If $C(Y)_{21,22} = 01$ (TA code = 1) and $C(Y)_{18,20} = 110$ or 111 an illegal procedure fault occurs.

Attempted repetition with the rpt, rpd, or rpl instructions causes an illegal procedure fault.

larn	Load Address Register <u>n</u>	76n (1)
------	--------------------------------	---------

FORMAT: EIS single-word instruction format (see Figure 4-1).

SUMMARY: For $n = 0, 1, \dots, \text{or } 7$ as determined by operation code
 $C(Y)_{0,23} \rightarrow C(ARn)$

MODIFICATIONS: All except du, dl, ci, sc, scr

INDICATORS: None affected

NOTES: Attempted repetition with the rpt, rpd, or rpl instructions causes an illegal procedure fault.

lareg	Load Address Registers	463 (1)
-------	------------------------	---------

FORMAT: EIS single-word instruction format (see Figure 4-1).

SUMMARY: For $i = 0, 1, \dots, 7$
 $C(Y\text{-block}8+i)_{0,23} \rightarrow C(ARi)$

MODIFICATIONS: All except du, dl, ci, sc, scr

INDICATORS: None affected

NOTES: Attempted repetition with the rpt, rpd, or rpl instructions causes an illegal procedure fault.

lpl	Load Pointers and Lengths	467 (1)
-----	---------------------------	---------

FORMAT: EIS single-word instruction format (see Figure 4-1).

SUMMARY: $C(Y\text{-block}8) \rightarrow C(\text{decimal unit data})$

MODIFICATIONS: All except du, dl, ci, sc, scr

INDICATORS: None affected

NOTES: See Section 3 for description and use of decimal unit data.

Attempted repetition with the rpt, rpd, or rpl instructions causes an illegal procedure fault.

<u>narn</u>	Numeric Descriptor to Address Register <u>n</u>	66 <u>n</u> (1)
-------------	---	-----------------

FORMAT: EIS single-word instruction format (see Figure 4-1).

SUMMARY: For n = 0, 1, ..., or 7 as determined by operation code

$C(Y)_{0,17} \rightarrow C(ARn.WORDNO)$

If $C(Y)_{21} = 0$ (TN code = 0), then

$C(Y)_{18,20} \rightarrow C(ARn.CHAR)$

0000 $\rightarrow C(ARn.BITNO)$

If $C(Y)_{21} = 1$ (TN code = 1), then

$(C(Y)_{18,20}) / 2 \rightarrow C(ARn.CHAR)$

$4 * (C(Y)_{18,20})_{\text{mod}2} + 1 \rightarrow C(ARn.BITNO)$

MODIFICATIONS: All except du, dl, ci, sc, scr

INDICATORS: None affected

NOTES: A numeric descriptor is fetched from Y and $C(Y)_{21}$ (TN bit) is examined.

If TN = 0 (9-bit data), then $C(Y)_{18,19}$ goes to $C(ARn.CHAR)$ and zeros fill $C(ARn.BITNO)$.

If TN = 1 (4-bit data), $C(Y)_{18,20}$ is appropriately translated to an equivalent character and bit position that goes to $C(ARn.CHAR)$ and $C(ARn.BITNO)$.

If $C(Y)_{21} = 0$ (TN code = 0) and $C(Y)_{20} = 1$ an illegal procedure fault occurs.

Attempted repetition with the rpt, rpd, or rpl instructions causes an illegal procedure fault.

EIS - ADDRESS REGISTER STORE

EIS - Address Register Store

<u>aran</u>	Address Register <u>n</u> to Alphanumeric Descriptor	54 <u>n</u> (1)
-------------	--	-----------------

FORMAT: EIS single-word instruction format (see Figure 4-1).

SUMMARY: For $n = 0, 1, \dots, \text{or } 7$ as determined by operation code

$C(\text{ARn.WORDNO}) \rightarrow C(\text{Y})_{0,17}$

If $C(\text{Y})_{21,22} = 00$ (TA code = 0), then

$C(\text{ARn.CHAR}) \rightarrow C(\text{Y})_{18,19}$

$0 \rightarrow C(\text{Y})_{20}$

If $C(\text{Y})_{21,22} = 01$ (TA code = 1), then

$(9 * C(\text{ARn.CHAR}) + C(\text{ARn.BITNO})) / 6 \rightarrow C(\text{Y})_{18,20}$

If $C(\text{Y})_{21,22} = 10$ (TA code = 2), then

$(9 * C(\text{ARn.CHAR}) + C(\text{ARn.BITNO}) - 1) / 4 \rightarrow C(\text{Y})_{18,20}$

MODIFICATIONS: All except du, dl, ci, sc, scr

INDICATORS: None affected

NOTES: This instruction is the inverse of the arn instruction.

The alphanumeric descriptor is fetched from Y and $C(\text{Y})_{21,22}$ (TA field) is examined to determine the data type described.

If TA = 0 (9-bit data), $C(\text{ARn.CHAR})$ goes to $C(\text{Y})_{18,19}$.

If TA = 1 (6-bit data) or TA = 2 (4-bit data), $C(\text{ARn.CHAR})$ and $C(\text{ARn.BITNO})$ are translated to an equivalent character position that goes to $C(\text{Y})_{18,20}$.

If $C(\text{Y})_{21,22} = 11$ (TA code = 3) or $C(\text{Y})_{23} = 1$ (unused bit), an illegal procedure fault occurs.

Attempted repetition with the rpt, rpd, or rpl instructions causes an illegal procedure fault.

<u>arnn</u>	Address Register <u>n</u> to Numeric Descriptor	64 <u>n</u> (1)
-------------	---	-----------------

FORMAT: EIS single-word instruction format (see Figure 4-1).

SUMMARY: For $n = 0, 1, \dots, \text{or } 7$ as determined by operation code

$C(\text{ARn.WORDNO}) \rightarrow C(\text{Y})_{0,17}$

If $C(\text{Y})_{21} = 0$ (TN code = 0), then

$C(\text{ARn.CHAR}) \rightarrow C(\text{Y})_{18,19}$

$0 \rightarrow C(\text{Y})_{20}$

If $C(\text{Y})_{21} = 1$ (TN code = 1), then

$(9 * C(\text{ARn.CHAR}) + C(\text{ARn.BITNO}) - 1) / 4 \rightarrow C(\text{Y})_{18,20}$

MODIFICATIONS: All except du, dl, ci, sc, scr

INDICATORS: None affected

NOTES: This instruction is the inverse of the narn instruction.

The numeric descriptor is fetched from Y and $C(\text{Y})_{21}$ (TN bit) is examined.

If TN = 0 (9-bit data), then $C(\text{ARn.CHAR})$ goes to $C(\text{Y})_{18,19}$.

If TN = 1 (4-bit data), then $C(\text{ARn.CHAR})$ and $C(\text{ARn.BITNO})$ are translated to an equivalent character position that goes to $C(\text{Y})_{18,20}$.

Attempted repetition with the rpt, rpd, or rpl instructions causes an illegal procedure fault.

<u>sarn</u>	Store Address Register <u>n</u>	$74n (1)$
-------------	---------------------------------	-----------

FORMAT: EIS single-word instruction format (see Figure 4-1).

SUMMARY: For $n = 0, 1, \dots, \text{or } 7$ as determined by operation code

$C(\text{ARn}) \rightarrow C(\text{Y})_{0,23}$

$00\dots0 \rightarrow C(\text{Y})_{24,35}$

MODIFICATIONS: All except du, dl, ci, sc, scr

INDICATORS: None affected

NOTES: Attempted repetition with the rpt, rpd, or rpl instructions causes an illegal procedure fault.

sareg	Store Address Registers	443 (1)
-------	-------------------------	---------

FORMAT: EIS single-word instruction format (see Figure 4-1).

SUMMARY: For $i = 0, 1, \dots, 7$
 $C(ARi) \rightarrow C(Y\text{-block}8+i)_{0,23}$
 $00\dots0 \rightarrow C(Y\text{-block}8+i)_{24,35}$

MODIFICATIONS: All except du, dl, ci, sc, scr

INDICATORS: None affected

NOTES: Attempted repetition with the rpt, rpd, or rpl instructions causes an illegal procedure fault.

spl	Store Pointers and Lengths	447 (1)
-----	----------------------------	---------

FORMAT: EIS single-word instruction format (see Figure 4-1).

SUMMARY: $C(\text{decimal unit data}) \rightarrow C(Y\text{-block}8)$

MODIFICATIONS: All except du, dl, ci, sc, scr

INDICATORS: None affected

NOTES: See Section 3 for description and use of decimal unit data.

Attempted repetition with the rpt, rpd, or rpl instructions causes an illegal procedure fault.

EIS - Address Register Special Arithmetic

a4bd	Add 4-bit Displacement to Address Register	502 (1)
------	--	---------

FORMAT:

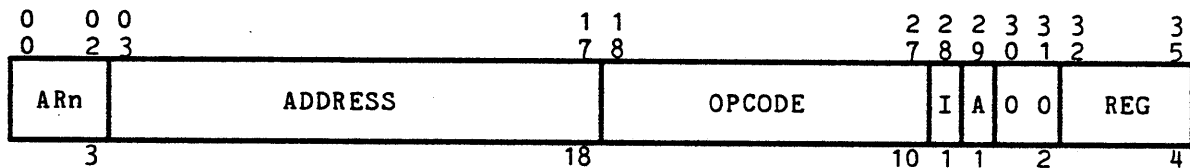

Figure 4-12. EIS Address Register Special Arithmetic Instruction Format

- ARn Number of address register selected
- ADDRESS Literal word displacement value
- OPCODE Instruction operation code
- I Interrupt inhibit bit
- A Use address register contents flag
- REG Any register modification except du, dl, ic

SUMMARY: If A = 0, then

ADDRESS + C(REG) / 4 -> C(ARn.WORDNO)

C(REG)_{mod4} -> C(ARn.CHAR)

4 * C(REG)_{mod2} + 1 -> C(ARn.BITNO)

 If A = 1, then

C(ARn.WORDNO) + ADDRESS + (9 * C(ARn.CHAR) + 4 * C(REG) + C(ARn.BITNO)) / 36 -> C(ARn.WORDNO)

((9 * C(ARn.CHAR) + 4 * C(REG) + C(ARn.BITNO))_{mod36}) / 9 -> C(ARn.CHAR)

4 * (C(ARn.CHAR) + 2 * C(REG) + C(ARn.BITNO) / 4)_{mod2} + 1 -> C(ARn.BITNO)

MODIFICATIONS: None except au, qu, al, ql, xn

INDICATORS: None affected

NOTES: The steps described in SUMMARY define special 4-bit addition arithmetic for ADDRESS, C(REG), C(ARn.WORDNO), C(ARn.CHAR), and C(ARn.BITNO).

C(REG) is always treated as a count of 4-bit characters.

The use of an address register is inherent; the value of bit 29 in the instruction word affects operand evaluation but not register selection.

Attempted repetition with the rpt, rpd, or rpl instructions causes an illegal procedure fault.

a6bd	Add 6-bit Displacement to Address Register	501 (1)
------	--	---------

FORMAT: EIS address register special arithmetic instruction format (see Figure 4-12).

SUMMARY:

If A = 0, then

$$\text{ADDRESS} + \text{C}(\text{REG}) / 6 \rightarrow \text{C}(\text{ARn.WORDNO})$$

$$((6 * \text{C}(\text{REG}))_{\text{mod}36}) / 9 \rightarrow \text{C}(\text{ARn.CHAR})$$

$$(6 * \text{C}(\text{REG}))_{\text{mod}9} \rightarrow \text{C}(\text{ARn.BITNO})$$

If A = 1, then

$$\text{C}(\text{ARn.WORDNO}) + \text{ADDRESS} + (9 * \text{C}(\text{ARn.CHAR}) + 6 * \text{C}(\text{REG}) + \text{C}(\text{ARn.BITNO})) / 36 \rightarrow \text{C}(\text{ARn.WORDNO})$$

$$((9 * \text{C}(\text{ARn.CHAR}) + 6 * \text{C}(\text{REG}) + \text{C}(\text{ARn.BITNO}))_{\text{mod}36}) / 9 \rightarrow \text{C}(\text{ARn.CHAR})$$

$$(9 * \text{C}(\text{ARn.CHAR}) + 6 * \text{C}(\text{REG}) + \text{C}(\text{ARn.BITNO}))_{\text{mod}9} \rightarrow \text{C}(\text{ARn.BITNO})$$

MODIFICATIONS: None except au, qu, al, ql, xn

INDICATORS: None Affected

NOTES:

The steps described in SUMMARY define special 6-bit addition arithmetic for ADDRESS, C(REG), C(ARn.WORDNO), C(ARn.CHAR), and C(ARn.BITNO).

C(REG) is always treated as a count of 6-bit characters.

The use of an address register is inherent; the value of bit 29 in the instruction word affects address preparation but not register selection.

Attempted repetition with the rpt, rpd, or rpl instructions causes an illegal procedure fault.

a9bd	Add 9-bit Displacement to Address Register	500 (1)
------	--	---------

FORMAT: EIS address register special arithmetic instruction format (see Figure 4-12).

SUMMARY: If A = 0, then
 $ADDRESS + C(REG) / 4 \rightarrow C(ARN.WORDNO)$
 $C(REG)_{mod4} \rightarrow C(ARN.CHAR)$
 If A = 1, then
 $C(ARN.WORDNO) + ADDRESS + (C(REG) + C(ARN.CHAR)) / 4 \rightarrow C(ARN.WORDNO)$
 $(C(ARN.CHAR) + C(REG))_{mod4} \rightarrow C(ARN.CHAR)$
 $0000 \rightarrow C(ARN.BITNO)$

MODIFICATIONS: None except au, qu, al, ql, xn

INDICATORS: None affected

NOTES: The steps described in SUMMARY define special 9-bit addition arithmetic for ADDRESS, C(REG), C(ARN.WORDNO), and C(ARN.CHAR).

C(REG) is always treated as a count of 9-bit bytes.

The use of an address register is inherent; the value of bit 29 in the instruction word affects operand evaluation but not register selection.

Attempted repetition with the rpt, rpd, or rpl instructions causes an illegal procedure fault.

abd	Add Bit Displacement to Address Register	503 (1)
-----	--	---------

FORMAT: EIS address register special arithmetic instruction format (see Figure 4-12).

SUMMARY: If A = 0, then
 $ADDRESS + C(REG) / 36 \rightarrow C(ARN.WORDNO)$
 $(C(REG)_{mod36}) / 9 \rightarrow C(ARN.CHAR)$
 $C(REG)_{mod9} \rightarrow C(ARN.BITNO)$
 If A = 1, then
 $C(ARN.WORDNO) + ADDRESS + (9 * C(ARN.CHAR) + 36 * C(REG) + C(ARN.BITNO)) / 36 \rightarrow C(ARN.WORDNO)$

EIS - ADDRESS REGISTER SPECIAL ARITHMETIC

$$((9 * C(ARn.CHAR) + 36 * C(REG) + C(ARn.BITNO))_{\text{mod}36}) / 9 \rightarrow C(ARn.CHAR)$$

$$(9 * C(ARn.CHAR) + 36 * C(REG) + C(ARn.BITNO))_{\text{mod}9} \rightarrow C(ARn.BITNO)$$

MODIFICATIONS: None except au, qu, al, ql, xn

INDICATORS: None affected

NOTES: The steps described in SUMMARY define special bit addition arithmetic for ADDRESS, C(REG), C(ARn.WORDNO), C(ARn.CHAR), and C(ARn.BITNO).

C(REG) is always treated as a bit count.

The use of an address register is inherent; the value of bit 29 in the instruction word affects operand evaluation but not register selection.

Attempted repetition with the rpt, rpd, or rpl instructions causes an illegal procedure fault.

awd	Add Word Displacement to Address Register	507 (1)
-----	---	---------

FORMAT: EIS address register special arithmetic instruction format (see Figure 4-12).

SUMMARY: If A = 0, then
ADDRESS + C(REG) → C(ARn.WORDNO)
If A = 1, then
C(ARn.WORDNO) + ADDRESS + C(REG) → C(ARn.WORDNO)
00 → C(ARn.CHAR)
0000 → C(ARn.BITNO)

MODIFICATIONS: None except au, qu, al, ql, xn

INDICATORS: None affected

NOTES: The use of an address register is inherent; the value of bit 29 in the instruction word affects operand evaluation but not register selection.

C(REG) is always treated as a word count.

Attempted repetition with the rpt, rpd, or rpl instructions causes an illegal procedure fault.

s4bd	Subtract 4-bit Displacement from Address Register	522 (1)
------	---	---------

FORMAT: EIS address register special arithmetic instruction format (see Figure 4-12).

SUMMARY:

If A = 0, then

$$- (\text{ADDRESS} + \text{C}(\text{REG}) / 4) \rightarrow \text{C}(\text{ARn.WORDNO})$$

$$- \text{C}(\text{REG})_{\text{mod}4} \rightarrow \text{C}(\text{ARn.CHAR})$$

$$- 4 * \text{C}(\text{REG})_{\text{mod}2} + 1 \rightarrow \text{C}(\text{ARn.BITNO})$$

If A = 1, then

$$\text{C}(\text{ARn.WORDNO}) - \text{ADDRESS} + (9 * \text{C}(\text{ARn.CHAR}) - 4 * \text{C}(\text{REG}) + \text{C}(\text{ARn.BITNO})) / 36 \rightarrow \text{C}(\text{ARn.WORDNO})$$

$$((9 * \text{C}(\text{ARn.CHAR}) - 4 * \text{C}(\text{REG}) + \text{C}(\text{ARn.BITNO}))_{\text{mod}36}) / 9 \rightarrow \text{C}(\text{ARn.CHAR})$$

$$4 * (\text{C}(\text{ARn.CHAR}) - 2 * \text{C}(\text{REG}) + \text{C}(\text{ARn.BITNO}) / 4)_{\text{mod}2} + 1 \rightarrow \text{C}(\text{ARn.BITNO})$$

MODIFICATIONS: None except au, qu, al, ql, xn

INDICATORS: None affected

NOTES:

The steps described in SUMMARY define special 4-bit subtraction arithmetic for ADDRESS, C(REG), C(ARn.WORDNO), C(ARn.CHAR), and C(ARn.BITNO).

C(REG) is always treated as a count of 4-bit characters.

The use of an address register is inherent; the value of bit 29 in the instruction word affects operand evaluation but not register selection.

Attempted repetition with the rpt, rpd, or rpl instructions causes an illegal procedure fault.

s6bd	Subtract 6-bit Displacement from Address Register	521 (1)
------	---	---------

FORMAT: EIS address register special arithmetic instruction format (see Figure 4-12).

SUMMARY: If A = 0, then

- $(\text{ADDRESS} + \text{C}(\text{REG}) / 6) \rightarrow \text{C}(\text{ARn.WORDNO})$
- $((6 * \text{C}(\text{REG}))_{\text{mod}36} / 9) \rightarrow \text{C}(\text{ARn.CHAR})$
- $(6 * \text{C}(\text{REG}))_{\text{mod}9} \rightarrow \text{C}(\text{ARn.BITNO})$

If A = 1, then

- $\text{C}(\text{ARn.WORDNO}) - \text{ADDRESS} + (9 * \text{C}(\text{ARn.CHAR}) - 6 * \text{C}(\text{REG}) + \text{C}(\text{ARn.BITNO})) / 36 \rightarrow \text{C}(\text{ARn.WORDNO})$
- $((9 * \text{C}(\text{ARn.CHAR}) - 6 * \text{C}(\text{REG}) + \text{C}(\text{ARn.BITNO}))_{\text{mod}36} / 9) \rightarrow \text{C}(\text{ARn.CHAR})$
- $(9 * \text{C}(\text{ARn.CHAR}) - 6 * \text{C}(\text{REG}) + \text{C}(\text{ARn.BITNO}))_{\text{mod}9} \rightarrow \text{C}(\text{ARn.BITNO})$

MODIFICATIONS: None except au, qu, al, ql, xn

INDICATORS: None Affected

NOTES: The steps described in SUMMARY define special 6-bit subtraction arithmetic for ADDRESS, C(REG), C(ARn.WORDNO), C(ARn.CHAR), and C(ARn.BITNO).

C(REG) is always treated as a count of 6-bit characters.

The use of an address register is inherent; the value of bit 29 in the instruction word affects operand evaluation but not register selection.

Attempted repetition with the rpt, rpd, or rpl instructions causes an illegal procedure fault.

s9bd	Subtract 9-bit Displacement from Address Register	520 (1)
------	---	---------

FORMAT: EIS address register special arithmetic instruction format (see Figure 4-12).

SUMMARY: If A = 0, then

- $(\text{ADDRESS} + \text{C}(\text{REG}) / 4) \rightarrow \text{C}(\text{ARn.WORDNO})$
- $\text{C}(\text{REG})_{\text{mod}4} \rightarrow \text{C}(\text{ARn.CHAR})$

If A = 1, then

$$C(ARn.WORDNO) - ADDRESS + (C(ARn.CHAR) - C(REG)) / 4 \rightarrow C(ARn.WORDNO)$$

$$(C(ARn.CHAR) - C(REG))_{\text{mod}4} \rightarrow C(ARn.CHAR)$$

$$0000 \rightarrow C(ARn.BITNO)$$

MODIFICATIONS: None except au, qu, al, qu, xn

INDICATORS: None affected

NOTES: The steps described in SUMMARY define special 9-bit subtraction arithmetic for ADDRESS, C(REG), C(ARn.WORDNO), and C(ARn.CHAR).

C(REG) is always treated as a count of 9-bit bytes.

The use of an address register is inherent: the value of bit 29 in the instruction word affects operand evaluation but not register selection.

Attempted repetition with the rpt, rpd, or rpl instructions causes an illegal procedure fault.

sbd	Subtract Bit Displacement from Address Register	523 (1)
-----	---	---------

FORMAT: EIS address register special arithmetic instruction format (see Figure 4-12).

SUMMARY: If A = 0, then

$$- (ADDRESS + C(REG) / 36) \rightarrow C(ARn.WORDNO)$$

$$- (C(REG)_{\text{mod}36}) / 9 \rightarrow C(ARn.CHAR)$$

$$- C(REG)_{\text{mod}9} \rightarrow - C(ARn.BITNO)$$

If A = 1, then

$$C(ARn.WORDNO) - ADDRESS + (9 * C(ARn.CHAR) - 36 * C(REG) + C(ARn.BITNO)) / 36 \rightarrow C(ARn.WORDNO)$$

$$((9 * C(ARn.CHAR) - 36 * C(REG) + C(ARn.BITNO))_{\text{mod}36}) / 9 \rightarrow C(ARn.CHAR)$$

$$(9 * C(ARn.CHAR) - 36 * C(REG) + C(ARn.BITNO))_{\text{mod}9} \rightarrow C(ARn.BITNO)$$

MODIFICATIONS: None except au, qu, al, ql, xn

INDICATORS: None affected

EIS - ADDRESS REGISTER SPECIAL ARITHMETIC

NOTES: The steps described in SUMMARY define special bit subtraction arithmetic for ADDRESS, C(REG), C(ARn.WORDNO), C(ARn.CHAR), and C(ARn.BITNO).

C(REG) is always treated as a bit count.

The use of an address register is inherent; the value of bit 29 in the instruction word affects operand evaluation but not register selection.

Attempted repetition with the rpt, rpd, or rpl instructions causes an illegal procedure fault.

swd	Subtract Word Displacement from Address Register	.527 (1)
-----	--	----------

FORMAT: EIS address register special arithmetic instruction format (see Figure 4-12).

SUMMARY: If A = 0, then
 - (ADDRESS + C(REG)) -> C(ARn.WORDNO)
 If A = 1, then
 C(ARn.WORDNO) - (ADDRESS + C(REG)) -> C(ARn.WORDNO)
 00 -> C(ARn.CHAR)
 0000 -> C(ARn.BITNO)

MODIFICATIONS: None except au, qu, al, ql, xn

INDICATORS: None Affected

NOTES: The use of an address register is inherent; the value of bit 29 in the instruction word affects operand evaluation but not register selection.

Attempted repetition with the rpt, rpd, or rpl instructions causes an illegal procedure fault.

EIS - Alphanumeric Compare

cmpc	Compare Alphanumeric Character Strings	106 (1)
------	--	---------

FORMAT:

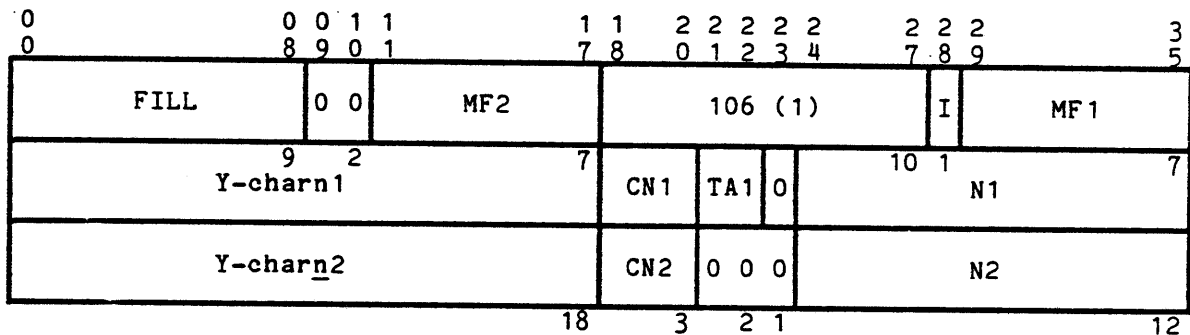

Figure 4-13. Compare Alphanumeric Character Strings (cmpc) EIS Multiword Instruction Format

- FILL Fill character for string extension
- MF1 Modification field for operand descriptor 1
- MF2 Modification field for operand descriptor 2
- I Interrupt inhibit bit
- Y-charn₁ Address of left-hand string
- CN1 First character position of left-hand string
- TA1 Data type of left-hand string
- N1 Length of left-hand string
- Y-charn₂ Address of right-hand string
- CN2 First character position of right-hand string
- N2 Length of right-hand string

ALM Coding Format:

cmpc (MF1),(MF2)[,fill(octalexpression)]
 desc_na Y-charn₁[(CN1)],N1 n = 4, 6, or 9 (TA1 = 2, 1, or 0)
 desc_na Y-charn₂[(CN2)],N2 n = 4, 6, or 9 (TA2 is ignored)

SUMMARY: For i = 1, 2, ..., minimum (N1,N2)
 C(Y-charn₁)_{i-1} :: C(Y-charn₂)_{i-1}
 If N1 < N2, then for i = N1+1, N1+2, ..., N2

EIS - ALPHANUMERIC COMPARE

$C(\text{FILL}) :: C(\text{Y-char}_2)_{i-1}$

If $N_1 > N_2$, then for $i = N_2+1, N_2+2, \dots, N_1$

$C(\text{Y-char}_1)_{i-1} :: C(\text{FILL})$

MODIFICATIONS: None except au, qu, al, ql, xn for MF1 and MF2

INDICATORS: (Indicators not listed are not affected)

Zero If $C(\text{Y-char}_1)_{i-1} = C(\text{Y-char}_2)_{i-1}$ for all i , then ON;
otherwise, OFF

Carry If $C(\text{Y-char}_1)_{i-1} < C(\text{Y-char}_2)_{i-1}$ for any i , then OFF;
otherwise ON

NOTES: Both strings are treated as the data type given for the left-hand string, TA1. A data type given for the right-hand string, TA2, is ignored.

Comparison is made on full 9-bit fields. If the given data type is not 9-bit ($TA1 \neq 0$), then characters from $C(\text{Y-char}_1)$ and $C(\text{Y-char}_2)$ are high-order zero filled. All 9 bits of $C(\text{FILL})$ are used.

Instruction execution proceeds until an inequality is found or the larger string length count is exhausted.

If $MF_k.RL = 1$, then N_k does not contain the operand length; instead, it contains a register code for a register holding the operand length.

If $MF_k.ID = 1$, then the k th word following the instruction word does not contain an operand descriptor; instead, it contains an indirect pointer to the operand descriptor.

Attempted execution with the xed instruction causes an illegal procedure fault.

Attempted repetition with the rpt, rpd, or rpl instructions causes an illegal procedure fault.

scd	Scan Characters Double	120 (1)
-----	------------------------	---------

FORMAT:

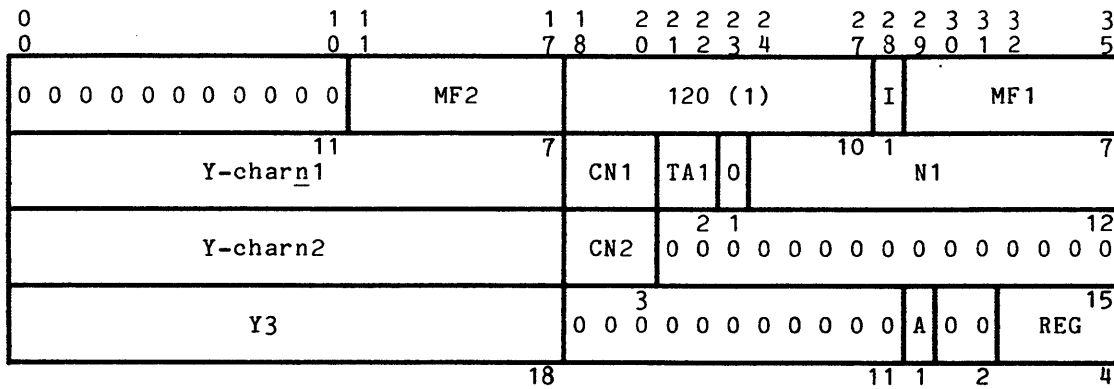

Figure 4-14. Scan Characters Double (scd) EIS Multiword Instruction Format

- MF1 Modification field for operand descriptor 1
- MF2 Modification field for operand descriptor 2
- I Interrupt inhibit bit
- Y-char_{n1} Address of string
- CN1 First character position of string
- TA1 Data type of string
- N1 Length of string
- Y-char_{n2} Address of test character pair
- CN2 First character position of test character pair
- Y3 Address of compare count word
- A Indirect via pointer register flag for Y3
- REG Register modifier for Y3

ALM Coding Format:

scd	(MF1),(MF2)	
desc _n a	Y- <u>char</u> _{n1} [(CN1)],N1	<u>n</u> = 4, 6, or 9 (TA1 = 2, 1, or 0)
desc _n a	Y- <u>char</u> _{n2} [(CN2)]	<u>n</u> = 4, 6, or 9 (TA2 is ignored)
arg	Y3[,tag]	

SUMMARY: For i = 1, 2, ..., N1-1

$$C(Y\text{-char}_{n1})_{i-1,i} :: C(Y\text{-char}_{n2})_{0,1}$$

EIS - ALPHANUMERIC COMPARE

On instruction completion, if a match was found:

00...0 -> C(Y3)_{0,11}

i-1 -> C(Y3)_{12,35}

If no match was found:

00...0 -> C(Y3)_{0,11}

N1-1 -> C(Y3)_{12,35}

MODIFICATIONS: None except au, qu, al, ql, xn for MF1 and REG
None except du, au, qu, al, ql, xn for MF2

INDICATORS: (Indicators not listed are not affected)

Tally If the string length count is exhausted without a match,
runout or if N1 = 1, then ON; otherwise OFF

NOTES: Both the string and the test character pair are treated as the data type given for the string, TA1. A data type given for the test character pair, TA2, is ignored.

Instruction execution proceeds until a character pair match is found or the string length count is exhausted.

If MFk.RL = 1, then Nk does not contain the operand length; instead, it contains a register code for a register holding the operand length.

If MFk.ID = 1, then the kth word following the instruction word does not contain an operand descriptor; instead, it contains an indirect pointer to the operand descriptor.

If MF2.ID = 0 and MF2.REG = du, then the second word following the instruction word does not contain an operand descriptor for the test character pair; instead, it contains the test character pair as a direct upper operand in bits 0,17.

Attempted execution with the xed instruction causes an illegal procedure fault.

Attempted repetition with the rpt, rpd, or rpl instructions causes an illegal procedure fault.

schr	Scan Characters Double in Reverse	121 (1)
------	-----------------------------------	---------

FORMAT: Same as Scan Characters Double (schr) format (see Figure 4-14).

SUMMARY: For i = 1, 2, ..., N1-1
C(Y-charn1)_{N1-i-1,N1-i} :: C(Y-charn2)_{0,1}

On instruction completion, if a match was found:

00...0 -> C(Y3)_{0,11}

i-1 -> C(Y3)_{12,35}

If no match was found:

00...0 -> C(Y3)_{0,11}

N1-1 -> C(Y3)_{12,35}

MODIFICATIONS: None except au, qu, al, ql, xn for MF1 and REG
None except du, au, qu, al, ql, xn for MF2

INDICATORS: (Indicators not listed are not affected)

Tally
runout

If the string length count is exhausted without a match,
or if N1 = 1, then ON; otherwise OFF

NOTES:

Both the string and the test character pair are treated as the data type given for the string, TA1. A data type given for the test character pair, TA2, is ignored.

Instruction execution proceeds until a character pair match is found or the string length count is exhausted.

If MF_k.RL = 1, then N_k does not contain the operand length; instead, it contains a register code for a register holding the operand length.

If MF_k.ID = 1, then the kth word following the instruction word does not contain an operand descriptor; instead, it contains an indirect pointer to the operand descriptor.

If MF2.ID = 0 and MF2.REG = du, then the second word following the instruction word does not contain an operand descriptor for the test character pair; instead, it contains the test character pair as a direct upper operand in bits 0,17.

Attempted execution with the xed instruction causes an illegal procedure fault.

Attempted repetition with the rpt, rpd, or rpl instructions causes an illegal procedure fault.

EIS - ALPHANUMERIC COMPARE

scm	Scan with Mask	124 (1)
-----	----------------	---------

FORMAT:

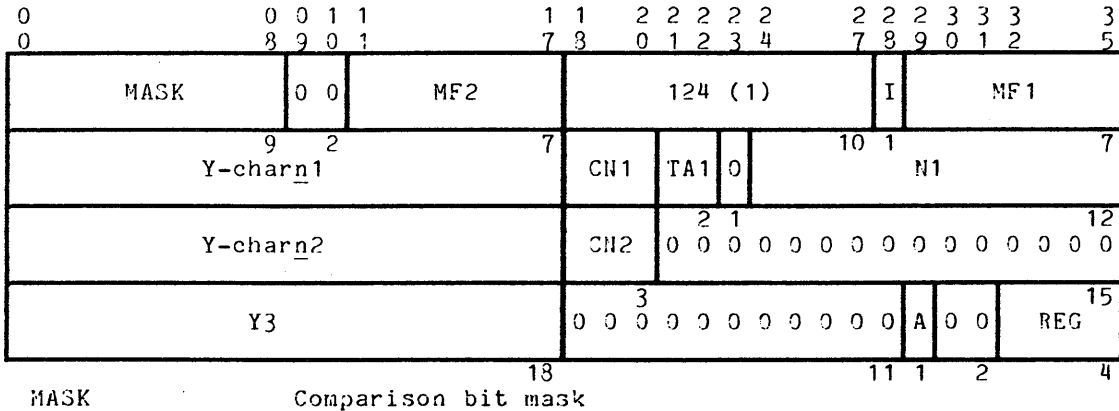

Figure 4-15. Scan with Mask (scm) EIS Multiword Instruction Format

- MF1 Modification field for operand descriptor 1
- MF2 Modification field for operand descriptor 2
- I Interrupt inhibit bit
- Y-char_n1 Address of string
- CN1 First character position of string
- TA1 Data type of string
- N1 Length of string
- Y-char_n2 Address of test character
- CN2 First character position of test character
- Y3 Address of compare count word
- A Indirect via pointer register flag for Y3
- REG Register modifier for Y3

ALM Coding Format:

```
scm                      (MF1),(MF2)[,mask(octalexpression)]
descna                Y-charn1[(CN1)],N1        n = 4, 6, or 9 (TA1 = 2, 1, or 0)
descna                Y-charn2[(CN2)]        n = 4, 6, or 9 (TA2 is ignored)
arg                     Y3[,tag]
```

SUMMARY: For characters i = 1, 2, ..., N1

For bits $j = 0, 1, \dots, 8$

$$C(Z)_j = \overline{C(MASK)_j} \& ((C(Y-charn1)_{i-1})_j \oplus (C(Y-charn2)_0)_j)$$

If $C(Z)_{0,8} = 00\dots0$, then

$00\dots0 \rightarrow C(Y3)_{0,11}$

$i-1 \rightarrow C(Y3)_{12,35}$

otherwise, continue scan of $C(Y-charn1)$

If a masked character match was not found, then

$00\dots0 \rightarrow C(Y3)_{0,11}$

$N1 \rightarrow C(Y3)_{12,35}$

MODIFICATIONS: None except au, qu, al, ql, xn for MF1 and REG
None except $du, au, qu, al, q\bar{1}, x\bar{n}$ for MF2

INDICATORS: (Indicators not listed are not affected)

Tally runout If the string length count exhausts, then ON;
otherwise, OFF

NOTES: Both the string and the test character are treated as the data type given for the string, TA1. A data type given for the test character, TA2, is ignored.

1 bits in $C(MASK)$ specify those bits of each character that will not take part in the masked comparison.

Instruction execution proceeds until a masked character match is found or the string length count is exhausted.

Masking and comparison is done on full 9-bit fields. If the given data type is not 9-bit ($TA1 \neq 0$), then characters from $C(Y-charn1)$ and $C(Y-charn2)$ are high-order zero filled. All 9 bits of $C(MASK)$ are used.

If $MF1.RL = 1$, then $N1$ does not contain the operand length; instead, it contains a register code for a register holding the operand length.

If $MFk.ID = 1$, then the k th word following the instruction word does not contain an operand descriptor; instead, it contains an indirect pointer to the operand descriptor.

If $MF2.ID = 0$ and $MF2.REG = du$, then the second word following the instruction word does not contain an operand descriptor for the test character; instead, it contains the test character as a direct upper operand in bits 0,8.

Attempted execution with the xed instruction causes an illegal procedure fault.

Attempted repetition with the rpt, rpd, or rpl instructions causes an illegal procedure fault.

EIS - ALPHANUMERIC COMPARE

scmr	Scan with Mask in Reverse	125 (1)
------	---------------------------	---------

FORMAT: Same as Scan with Mask (scm) format (see Figure 4-15).

SUMMARY: For characters $i = 1, 2, \dots, N1$

For bits $j = 0, 1, \dots, 8$

$$C(Z)_j = \overline{C(MASK)_j} \& ((C(Y-charn1)_{N1-i})_j \oplus (C(Y-charn2)_0)_j)$$

If $C(Z)_{0,8} = 00\dots0$, then

$00\dots0 \rightarrow C(Y3)_{0,11}$

$i-1 \rightarrow C(Y3)_{12,35}$

otherwise, continue scan of $C(Y-charn1)$

If a masked character match was not found, then

$00\dots0 \rightarrow C(Y3)_{0,11}$

$N1 \rightarrow C(Y3)_{12,35}$

MODIFICATIONS: None except au, qu, al, ql, xn for MF1 and REG
None except du, au, qu, al, qI, xN for MF2

INDICATORS: (Indicators not listed are not affected)

Tally runout If the string length count exhausts, then ON;
otherwise, OFF

NOTES: Both the string and the test character are treated as the data type given for the string, TA1. A data type given for the test character, TA2, is ignored.

1 bits in $C(MASK)$ specify those bits of each character that will not take part in the masked comparison.

Instruction execution proceeds until a masked character match is found or the string length count is exhausted.

Masking and comparison is done on full 9-bit fields. If the given data type is not 9-bit ($TA1 \neq 0$), then characters from $C(Y-charn1)$ and $C(Y-charn2)$ are high-order zero filled. All 9 bits of $C(MASK)$ are used.

If $MF1.RL = 1$, then $N1$ does not contain the operand length; instead, it contains a register code for a register holding the operand length.

If $MFk.ID = 1$, then the k th word following the instruction word does not contain an operand descriptor; instead, it contains an indirect pointer to the operand descriptor.

If $MF2.ID = 0$ and $MF2.REG = du$, then the second word following the instruction word does not contain an operand descriptor

EIS - ALPHANUMERIC COMPARE

for the test character; instead, it contains the test character as a direct upper operand in bits 0,8.

Attempted execution with the xed instruction causes an illegal procedure fault.

Attempted repetition with the rpt, rpd, or rpl instructions causes an illegal procedure fault.

tct	Test Character and Translate	164 (1)
-----	------------------------------	---------

FORMAT:

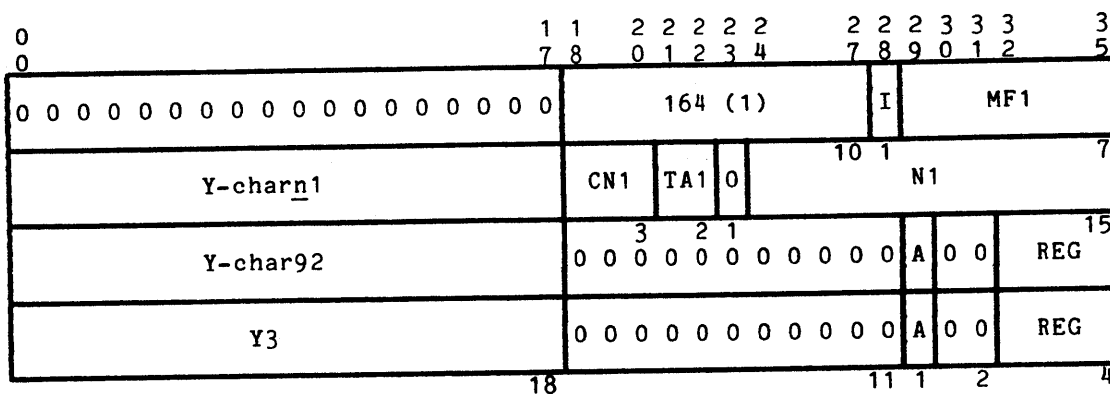

Figure 4-16. Test Character and Translate (tct) EIS Multiword Instruction Format

- MF1 Modification field for operand descriptor 1
- I Interrupt inhibit bit
- Y-charn₁ Address of string
- CN1 First character position of string
- TA1 Data type of string
- N1 Length of string
- Y-char92 Address of character translation table
- Y3 Address of result word
- A Indirect via pointer register flag for Y2 and Y3
- REG Register modifier for Y2 and Y3

ALM Coding Format:

tct (MF1)
 desc_{na} Y-charn₁[(CN1)],N1 n = 4, 6, or 9 (TA1 = 2, 1, or 0)
 arg Y-char92[,tag]
 arg Y3[,tag]

EIS - ALPHANUMERIC COMPARE

SUMMARY: For $i = 1, 2, \dots, N1$
 $m = C(Y\text{-char}1)_{i-1}$
If $C(Y\text{-char}92)_m \neq 00\dots 0$, then
 $C(Y\text{-char}92)_m \rightarrow C(Y3)_{0,8}$
 $000 \rightarrow C(Y3)_{9,11}$
 $i-1 \rightarrow C(Y3)_{12,35}$
otherwise, continue scan of $C(Y\text{-char}1)$
If a non-zero table entry was not found, then
 $00\dots 0 \rightarrow C(Y3)_{0,11}$
 $N1 \rightarrow C(Y3)_{12,35}$

MODIFICATIONS: None except au, qu, al, ql, x_n for MF1 and REG

INDICATORS: (Indicators not listed are not affected)

Tally runout If the string length count exhausts, then ON;
otherwise, OFF

NOTES: If the data type of the string to be scanned is not 9-bit
(TA1 \neq 0), then characters from $C(Y\text{-char}1)$ are high-order
zero filled in forming the table index, \bar{m} .
Instruction execution proceeds until a non-zero table entry
is found or the string length count is exhausted.
If MF1.RL = 1, then N1 does not contain the operand length;
instead, it contains a register code for a register holding
the operand length.
If MF1.ID = 1, then the first word following the instruction
word does not contain an operand descriptor; instead, it
contains an indirect pointer to the operand descriptor.
Attempted execution with the xed instruction causes an illegal
procedure fault.
Attempted repetition with the rpt, rpd, or rpl instructions
causes an illegal procedure fault.
The character number of Y-char92 must be zero, i.e., Y-char92
must start on a word boundary.
If a non-zero table entry was not found, then
 $00\dots 0 \rightarrow C(Y3)_{0,11}$
 $N1 \rightarrow C(Y3)_{12,35}$

tctr	Test Character and Translate in Reverse	165 (1)
------	---	---------

FORMAT: Same as Test Character and Translate (tct) format (see Figure 4-16).

SUMMARY: For $i = 1, 2, \dots, N1$

$m = C(Y\text{-char}_{N1})_{N1-i}$

If $C(Y\text{-char}_{92})_m \neq 00\dots 0$, then

$C(Y\text{-char}_{92})_m \rightarrow C(Y3)_{0,8}$

$000 \rightarrow C(Y3)_{9,11}$

$i-1 \rightarrow C(Y3)_{12,35}$

otherwise, continue scan of $C(Y\text{-char}_{N1})$

If a non-zero table entry was not found, then

$00\dots 0 \rightarrow C(Y3)_{0,11}$

$N1 \rightarrow C(Y3)_{12,35}$

MODIFICATIONS: None except au, qu, al, ql, x_n for MF1 and REG

INDICATORS: (Indicators not listed are not affected)

Tally runoff If the string length count exhausts, then ON; otherwise, OFF

NOTES: If the data type of the string to be scanned is not 9-bit ($TA1 \neq 0$), then characters from $C(Y\text{-char}_{N1})$ are high-order zero filled in forming the table index, m .

Instruction execution proceeds until a non-zero table entry is found or the string length count is exhausted.

If $MF1.RL = 1$, then $N1$ does not contain the operand length; instead, it contains a register code for a register holding the operand length.

If $MF1.ID = 1$, then the first word following the instruction word does not contain an operand descriptor; instead, it contains an indirect pointer to the operand descriptor.

Attempted execution with the xed instruction causes an illegal procedure fault.

Attempted repetition with the rpt, rpd, or rpl instructions causes an illegal procedure fault.

EIS - ALPHANUMERIC MOVE

EIS - Alphanumeric Move

mlr	Move Alphanumeric Left to Right	100 (1)
-----	---------------------------------	---------

FORMAT:

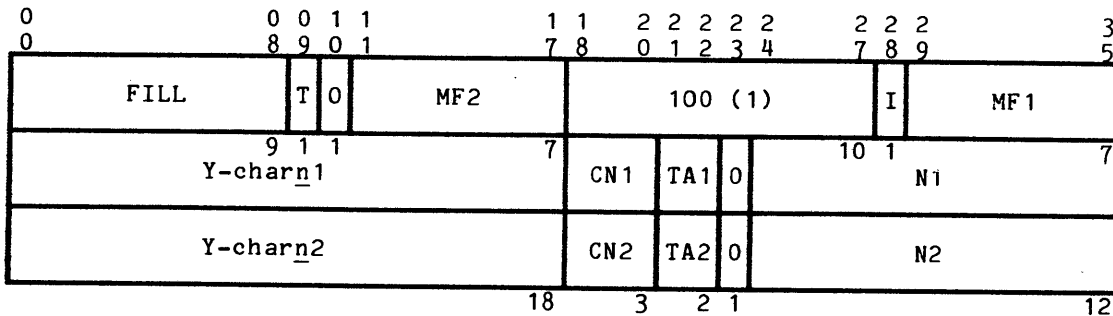

Figure 4-17. Move Alphanumeric Left to Right (mlr) EIS Multiword Instruction Format

- FILL Fill character for string extension
- T Truncation fault enable bit
- MF1 Modification field for operand descriptor 1
- MF2 Modification field for operand descriptor 2
- Y-charn₁ Address of sending string
- CN1 First character position of sending string
- TA1 Data type of sending string
- N1 Length of sending string
- Y-charn₂ Address of receiving string
- CN2 First character position of receiving string
- TA2 Data type of receiving string
- N2 Length of receiving string

ALM Coding Format:

```
mlr            (MF1),(MF2)[,fill(octalexpression)][,enablefault]
descna        Y-charn1[(CN1)],N1        n = 4, 6, or 9 (TA1 = 2, 1, or 0)
descna        Y-charn2[(CN2)],N2        n = 4, 6, or 9 (TA2 = 2, 1, or 0)
```

SUMMARY: For i = 1, 2, ..., minimum (N1,N2)
 C(Y-charn₁)_{i-1} -> C(Y-charn₂)_{i-1}

If $N1 < N2$, then for $i = N1+1, N1+2, \dots, N2$

$C(\text{FILL}) \rightarrow C(\text{Y-char}_2)_{i-1}$

MODIFICATIONS: None except au, qu, al, ql, xn for MF1 and MF2

INDICATORS: (Indicators not listed are not affected)

Truncation If $N1 > N2$ then ON; otherwise OFF

NOTES: If data types are dissimilar ($TA1 \neq TA2$), each character is high-order truncated or zero filled, as appropriate, as it is moved. No character conversion takes place.

If $N1 > N2$, then $(N1-N2)$ trailing characters of $C(\text{Y-char}_1)$ are not moved and the truncation indicator is set ON.

If $N1 < N2$ and $TA2 = 2$ (4-bit data) or 1 (6-bit data), then FILL characters are high-order truncated as they are moved to $C(\text{Y-char}_2)$. No character conversion takes place.

If $N1 < N2$, $C(\text{FILL})_0 = 1$, $TA1 = 1$, and $TA2 = 2$, then $C(\text{Y-char}_1)_{N1-1}$ is examined for a GBCD overpunch sign. If a negative overpunch sign is found, then the minus sign character is placed in $C(\text{Y-char}_2)_{N2-1}$; otherwise, a plus sign character is placed in $C(\text{Y-char}_2)_{N2-1}$.

If $MFk.RL = 1$, then Nk does not contain the operand length; instead, it contains a register code for a register holding the operand length.

If $MFk.ID = 1$, then the k th word following the instruction word does not contain an operand descriptor; instead, it contains an indirect pointer to the operand descriptor.

$C(\text{Y-char}_1)$ and $C(\text{Y-char}_2)$ may be overlapping strings; no check is made. This feature is useful for replication of substrings within a larger string, but care must be exercised in the construction of the operand descriptors so that sending string, $C(\text{Y-char}_1)$, data is not inadvertently destroyed.

The user of string replication or overlaying is warned that the decimal unit addresses the main memory in unaligned (not on modulo 8 boundary) units of Y-block8 words and that the overlaid string, $C(\text{Y-char}_2)$, is not returned to main memory until the unit of Y-block8 words is filled or the instruction completes.

If $T = 1$ and the truncation indicator is set ON by execution of the instruction, then a truncation (overflow) fault occurs.

Attempted execution with the xed instruction causes an illegal procedure fault.

Attempted repetition with the rpt, rpd, or rpl instructions causes an illegal procedure fault.

mrl	Move Alphanumeric Right to Left	101 (1)
-----	---------------------------------	---------

FORMAT: Same as Move Alphanumeric Left to Right (mlr) format (see Figure 4-17).

SUMMARY: For $i = 1, 2, \dots$, minimum (N_1, N_2)

$C(Y\text{-char}_{n1})_{N1-i} \rightarrow C(Y\text{-char}_{n2})_{N2-i}$

If $N_1 < N_2$, then for $i = N_1+1, N_2+1, \dots, N_2$

$C(\text{FILL}) \rightarrow C(Y\text{-char}_{n2})_{N2-i}$

MODIFICATIONS: None except au, qu, al, ql, x_n for MF1 and MF2

INDICATORS: (Indicators not listed are not affected)

Truncation If $N_1 > N_2$ then ON; otherwise OFF

NOTES: If data types are dissimilar ($TA_1 \neq TA_2$), each character is high-order truncated or zero filled, as appropriate, as it is moved. No character conversion takes place.

If $N_1 > N_2$, then $(N_1 - N_2)$ leading characters of $C(Y\text{-char}_{n1})$ are not moved and the truncation indicator is set ON.

If $N_1 < N_2$ and $TA_2 = 2$ (4-bit data) or 1 (6-bit data), then FILL characters are high-order truncated as they are moved to $C(Y\text{-char}_{n2})$. No character conversion takes place.

If $MFk.RL = 1$, then N_k does not contain the operand length; instead, it contains a register code for a register holding the operand length.

If $MFk.ID = 1$, then the k th word following the instruction word does not contain an operand descriptor; instead, it contains an indirect pointer to the operand descriptor.

$C(Y\text{-char}_{n1})$ and $C(Y\text{-char}_{n2})$ may be overlapping strings; no check is made. This feature is useful for replication of substrings within a larger string, but care must be exercised in the construction of the operand descriptors so that sending string, $C(Y\text{-char}_{n1})$, data is not inadvertently destroyed.

The user of string replication or overlaying is warned that the decimal unit addresses the main memory in unaligned (not on modulo 8 boundary) units of Y-block8 words and that the overlaid string, $C(Y\text{-char}_{n2})$, is not returned to main memory until the unit of Y-block8 words is filled or the instruction completes.

If T = 1 and the truncation indicator is set ON by execution of the instruction, then a truncation (overflow) fault occurs.

Attempted execution with the xed instruction causes an illegal procedure fault.

Attempted repetition with the rpt, rpd, or rpl instructions causes an illegal procedure fault.

mve	Move Alphanumeric Edited	020 (1)
-----	--------------------------	---------

FORMAT:

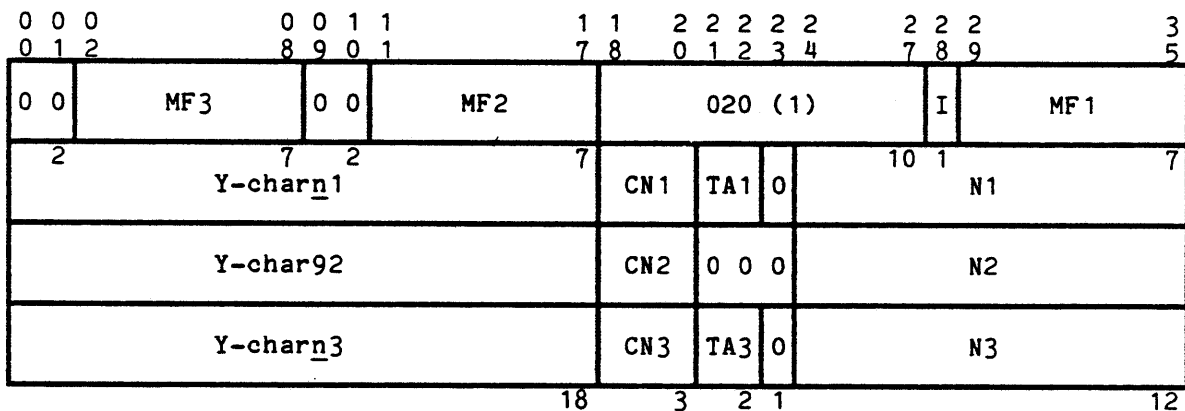

Figure 4-18. Move Alphanumeric Edited (mve) EIS Multiword Instruction Format

- MF1 Modification field for operand descriptor 1
- MF2 Modification field for operand descriptor 2
- MF3 Modification field for operand descriptor 3
- I Interrupt inhibit bit
- Y-charn₁ Address of sending string
- CN1 First character position of sending string
- TA1 Data type of sending string
- N1 Length of sending string
- Y-char92 Address of MOP control string
- CN2 First character position of MOP control string
- N2 Length of MOP control string
- Y-charn₃ Address of receiving string
- CN3 First character position of receiving string

TA3 Data type of receiving string
 N3 Length of receiving string

ALM Coding Format:

mve	(MF1),(MF2),(MF3)	
desc _{na}	Y-char _{n1} [(CN1)],N1	<u>n</u> = 4, 6, or 9 (TA1 = 2, 1, or 0)
desc _{9a}	Y-char ₉₂ [(CN2)],N2	
desc _{na}	Y-char _{n3} [(CN3)],N3	<u>n</u> = 4, 6, or 9 (TA3 = 2, 1, or 0)

SUMMARY: C(Y-char_{n1}) -> C(Y-char_{n3}) under C(Y-char₉₂) MOP control
 See "Micro Operations for Edit Instructions" later in this section for details of editing under MOP control.

MODIFICATIONS: None except au, qu, al, ql, x_n for MF1, MF2, and MF3

INDICATORS: None affected

NOTES: If data types are dissimilar (TA1 ≠ TA3), each character of C(Y-char_{n1}) is high-order truncated or zero filled, as appropriate, as it is moved. No character conversion takes place.

If the data type of the receiving string is not 9-bit (TA3 ≠ 0), then insertion characters are high-order truncated as they are inserted.

The maximum string length is 63. The count fields N1, N2, and N3 are treated as modulo 64 numbers.

The instruction completes normally only if N3 is the first tally to exhaust: otherwise, an illegal procedure fault occurs.

If MF_k.RL = 1, then N_k does not contain the operand length; instead, it contains a register code for a register holding the operand length.

If MF_k.ID = 1, then the kth word following the instruction word does not contain an operand descriptor; instead, it contains an indirect pointer to the operand descriptor.

C(Y-char_{n1}) and C(Y-char_{n3}) may be overlapping strings; no check is made. This feature is useful for replication of substrings within a larger string, but care must be exercised in the construction of the operand descriptors so that sending string, C(Y-char_{n1}), data is not inadvertently destroyed.

The user of string replication or overlaying is warned that the decimal unit addresses the main memory in unaligned (not on modulo 8 boundary) units of Y-block8 words and that the overlaid string, C(Y-char_{n3}), is not returned to main memory until the unit of Y-block8 words is filled or the instruction completes.

Attempted execution with the xed instruction causes an illegal procedure fault.

Attempted repetition with the rpt, rpd, or rpl instructions causes an illegal procedure fault.

mvt	Move Alphanumeric with Translation	160 (1)
-----	------------------------------------	---------

FORMAT:

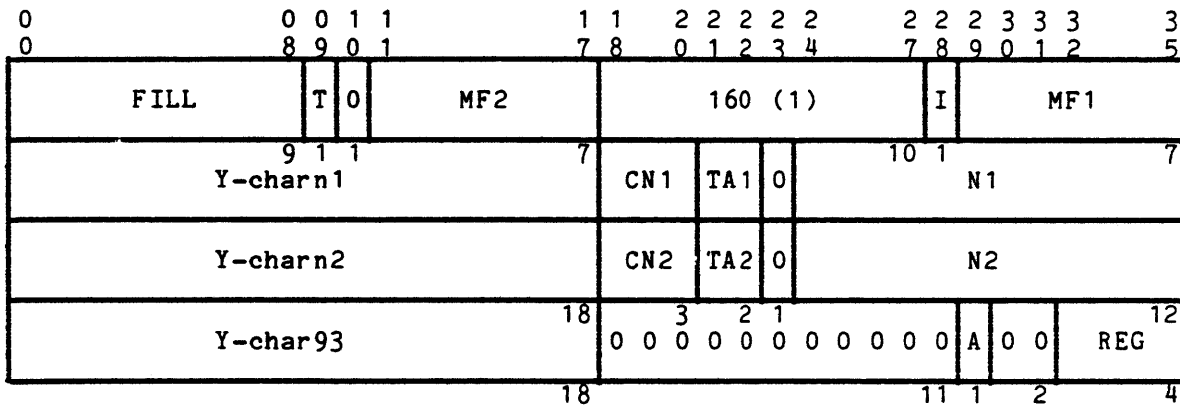

Figure 4-1. Move Alphanumeric with Translation (mvt) EIS Multiword Instruction Format

- FILL Fill character for string extension
- T Truncation fault enable bit
- MF1 Modification field for operand descriptor 1
- MF2 Modification field for operand descriptor 2
- Y-charn1 Address of sending string
- CN1 First character position of sending string
- TA1 Data type of sending string
- N1 Length of sending string
- Y-charn2 Address of receiving string
- CN2 First character position of receiving string
- TA2 Data type of receiving string
- N2 Length of receiving string
- Y-char93 Address of character translation table
- A Indirect via pointer register flag for Y-char93

REG Register modifier for Y-char93

ALM Coding Format:

```

mvt      (MF1),(MF2)[,fill(octalexpression)][,enablefault]
descna   Y-charn1[(CN1)],N1      n = 4, 6, or 9 (TA1 = 2, 1, or 0)
descna   Y-charn2[(CN2)],N2      n = 4, 6, or 9 (TA2 = 2, 1, or 0)
arg      Y-char93[,tag]

```

SUMMARY: For $i = 1, 2, \dots$, minimum (N1,N2)

$$m = C(Y\text{-charn}_1)_{i-1}$$

$$C(Y\text{-char93})_m \rightarrow C(Y\text{-charn}_2)_{i-1}$$

If $N1 < N2$, then for $i = N1+1, N1+2, \dots, N2$

$$m = C(\text{FILL})$$

$$C(Y\text{-char93})_m \rightarrow C(Y\text{-charn}_2)_{i-1}$$

MODIFICATIONS: None except au, qu, al, ql, xn for MF1, MF2, and REG

INDICATORS: (Indicators not listed are not affected)

Truncation If $N1 > N2$ then ON; otherwise OFF

NOTES: If the data type of the receiving field is not 9-bit ($TA2 \neq 0$), then characters from $C(Y\text{-char93})$ are high-order truncated, as appropriate, as they are moved.

If the data type of the sending field is not 9-bit ($TA1 \neq 0$), then characters from $C(Y\text{-charn}_1)$ are high-order zero filled when forming the table index.

If $N1 > N2$, then $(N1-N2)$ trailing characters of $C(Y\text{-charn}_1)$ are not moved and the truncation indicator is set ON.

If $MFk.RL = 1$, then Nk does not contain the operand length; instead, it contains a register code for a register holding the operand length.

If $MFk.ID = 1$, then the k th word following the instruction word does not contain an operand descriptor; instead, it contains an indirect pointer to the operand descriptor.

$C(Y\text{-charn}_1)$ and $C(Y\text{-charn}_2)$ may be overlapping strings; no check is made. This feature is useful for replication of substrings within a larger string, but care must be exercised in the construction of the operand descriptors so that sending string, $C(Y\text{-charn}_1)$, data is not inadvertently destroyed.

The user of string replication or overlaying is warned that the decimal unit addresses the main memory in unaligned (not on modulo 8 boundary) units of Y-block8 words and that the overlaid string, $C(Y\text{-charn}_2)$, is not

returned to main memory until the unit of Y-block8 words is filled or the instruction completes.

If T = 1 and the truncation indicator is set ON by execution of the instruction, then a truncation (overflow) fault occurs.

Attempted execution with the xed instruction causes an illegal procedure fault.

Attempted repetition with the rpt, rpd, or rpl instructions causes an illegal procedure fault.

EIS - NUMERIC COMPARE

EIS - Numeric Compare

cmpn	Compare Numeric	303 (1)
------	-----------------	---------

FORMAT:

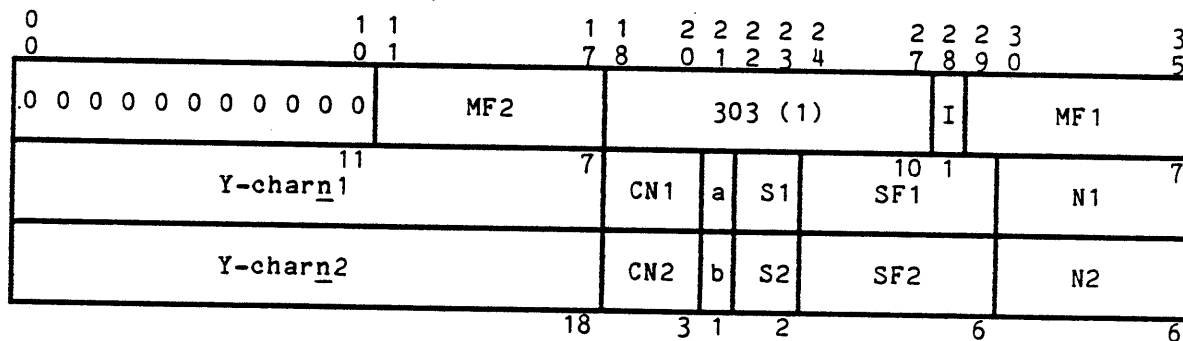

Figure 4-20. Compare Numeric (cmpn) EIS Multiword Instruction Format

key

- MF1 Modification field for operand descriptor 1
- MF2 Modification field for operand descriptor 2
- I Interrupt inhibit bit
- Y-charn₁ Address of left-hand number
- CN1 First character position of left-hand number
- a TN1 Data type of left-hand number
- S1 Sign and decimal type of left-hand number
- SF1 Scaling factor of left-hand number
- N1 Length of left-hand number
- Y-charn₂ Address of right-hand number
- CN2 First character position of right-hand number
- b TN2 Data type of right-hand number
- S2 Sign and decimal type of right-hand number
- SF2 Scaling factor of right-hand number
- N2 Length of right-hand string

ALM Coding Format:

cmpn	(MF1),(MF2)	
descn[f1,ls,ns,ts]	Y-charn1[(CN1)],N1,SF1	n = 4 or 9
descn[f1,ls,ns,ts]	Y-charn2[(CN2)],N2,SF2	n = 4 or 9

SUMMARY: C(Y-charn1) :: C(Y-charn2) as numeric values

MODIFICATIONS: None except au, qu, al, ql, xn for MF1 and MF2

INDICATORS: (Indicators not listed are not affected)

Zero	If C(Y-charn1) = C(Y-charn2), then ON; otherwise OFF
Negative	If C(Y-charn1) > C(Y-charn2), then ON; otherwise OFF
Carry	If C(Y-charn1) > C(Y-charn2) , then OFF, otherwise ON

NOTES: Comparison is made on 4-bit numeric values contained in each character of C(Y-charnk). If either given data type is 9-bit (TNk = 0), characters from C(Y-char9k) are high-order truncated to 4 bits before comparison.

Sign characters are located according to information in CNk, Sk, and Nk and interpreted as 4-bit fields; 9-bit sign characters are high-order truncated before interpretation. The sign character 15₈ is interpreted as a minus sign; all other legal sign characters are interpreted as plus signs.

The position of the decimal point in C(Y-charnk) is determined from information in CNk, Sk, SFk, and Nk.

Comparison begins at the decimal position corresponding to the first digit of the operand with the larger number of integer digits and ends with the last digit of the operand with the larger number of fraction digits.

Four-bit numeric zeros are used to represent digits to the left of the first given digit of the operand with the smaller number of integer digits.

Four-bit numeric zeros are used to represent digits to the right of the last given digit of the operand with the smaller number of fraction digits.

Instruction execution proceeds until an inequality is found or the larger string length count is exhausted.

If MFk.RL = 1, then Nk does not contain the operand length; instead, it contains a register code for a register holding the operand length.

If MFk.ID = 1, then the kth word following the instruction word does not contain an operand descriptor; instead, it contains an indirect pointer to the operand descriptor.

Detection of a character outside the range [0,11]₈ in a digit position or a character outside the range [12,17]₈ in a sign position causes an illegal procedure fault.

EIS - NUMERIC COMPARE

Attempted execution with the xed instruction causes an illegal procedure fault.

Attempted repetition with the rpt, rpd, or rpl instructions causes an illegal procedure fault.

EIS - Numeric Move

mvn	Move Numeric	300 (1)
-----	--------------	---------

FORMAT:

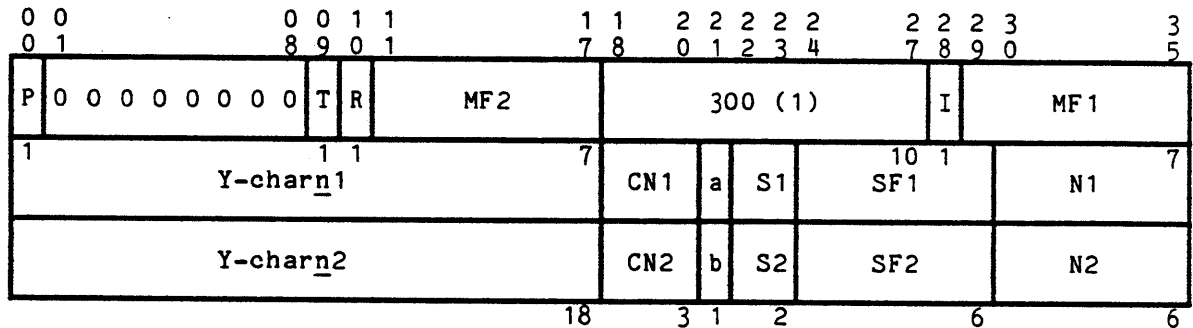

Figure 4-21. Move Numeric (mvn) EIS Multiword Instruction Format

key

- P 4-bit data sign character control
- T Truncation fault enable bit
- R Rounding flag
- MF1 Modification field for operand descriptor 1
- MF2 Modification field for operand descriptor 2
- I Interrupt inhibit bit
- Y-charn₁ Address of sending number
- CN1 First character position of sending number
- a TN1 Data type of sending number
- S1 Sign and decimal type of sending number
- SF1 Scaling factor of sending number
- N1 Length of sending number
- Y-charn₂ Address of receiving number
- CN2 First character position of receiving number
- b TN2 Data type of receiving number
- S2 Sign and decimal type of receiving number
- SF2 Scaling factor of receiving number
- N2 Length of receiving string

ALM Coding Format:

```

mvn                (MF1),(MF2)[,enablefault][,round]
descn[f1,ls,ns,ts] Y-charn1[(CN1)],N1,SF1      n = 4 or 9
descn[f1,ls,ns,ts] Y-charn2[(CN2)],N2,SF2      n = 4 or 9

```

SUMMARY C(Y-charn1) converted and/or rescaled -> C(Y-charn2)

MODIFICATIONS: None except au, qu, al, ql, xn for MF1 and MF2

INDICATORS: (Indicators not listed are not affected)

Zero If C(Y-charn2) = decimal 0, then ON; otherwise OFF

Negative If a minus sign character is moved to C(Y-charn2), then ON; otherwise OFF

Truncation If low-order digit truncation occurs without rounding, then ON; otherwise OFF

Overflow If fixed-point integer overflow occurs, then ON; otherwise unchanged. (see NOTES)

Exponent overflow If exponent of floating-point result exceeds +127, then ON; otherwise unchanged.

Exponent underflow If exponent of floating-point result is less than -128, then ON; otherwise unchanged.

NOTES: If data types are dissimilar (TN1 ≠ TN2), each character is high-order truncated or filled, as appropriate, as it is moved. The fill data used is "00011"b for digit characters and "00010"b for sign characters.

If TN2 and S2 specify a 4-bit signed number and P = 1, then a legal plus sign character in C(Y-charn1) is converted to 13₈ as it is moved.

If N2 is not large enough to hold the integer part of C(Y-charn1) as rescaled by SF2, an overflow condition exists; the overflow indicator is set ON and an overflow fault occurs. This implies that an unsigned fixed-point receiving field has a minimum length of 1 character; a signed fixed-point field, 2 characters; and a floating-point field, 3 characters.

If N2 is not large enough to hold all the given digits of C(Y-charn1) as rescaled by SF2 and R = 0, then a truncation condition exists; data movement stops when C(Y-charn2) is filled and the truncation indicator is set ON. If R = 1, then the last digit moved is rounded according to the absolute value of the remaining digits of C(Y-charn1) and the instruction completes normally.

If MFk.RL = 1, then Nk does not contain the operand length; instead, it contains a register code for a register holding the operand length.

If $MF_k.ID = 1$, then the k th word following the instruction word does not contain an operand descriptor; instead, it contains an indirect pointer to the operand descriptor.

$C(Y\text{-char}_1)$ and $C(Y\text{-char}_2)$ may be overlapping strings; no check is made. This feature is useful for replication of substrings within a larger string, but care must be exercised in the construction of the operand descriptors so that sending string, $C(Y\text{-char}_1)$, data is not inadvertently destroyed. Difficulties may be encountered because of scaling factors and the special treatment of sign characters and floating-point exponents.

The user of string replication or overlaying is warned that the decimal unit addresses the main memory in unaligned (not on modulo 8 boundary) units of $Y\text{-block}_8$ words and that the overlaid string, $C(Y\text{-char}_2)$, is not returned to main memory until the unit of $Y\text{-block}_8$ words is filled or the instruction completes.

If $T = 1$ and the truncation indicator is set ON by execution of the instruction, then a truncation (overflow) fault occurs.

Detection of a character outside the range $[0,11]_8$ in a digit position or a character outside the range $[12,17]_8$ in a sign position causes an illegal procedure fault.

Attempted execution with the xed instruction causes an illegal procedure fault.

Attempted repetition with the rpt , rpd , or rpl instructions causes an illegal procedure fault.

mvne	Move Numeric Edited	024 (1)
------	---------------------	---------

FORMAT:

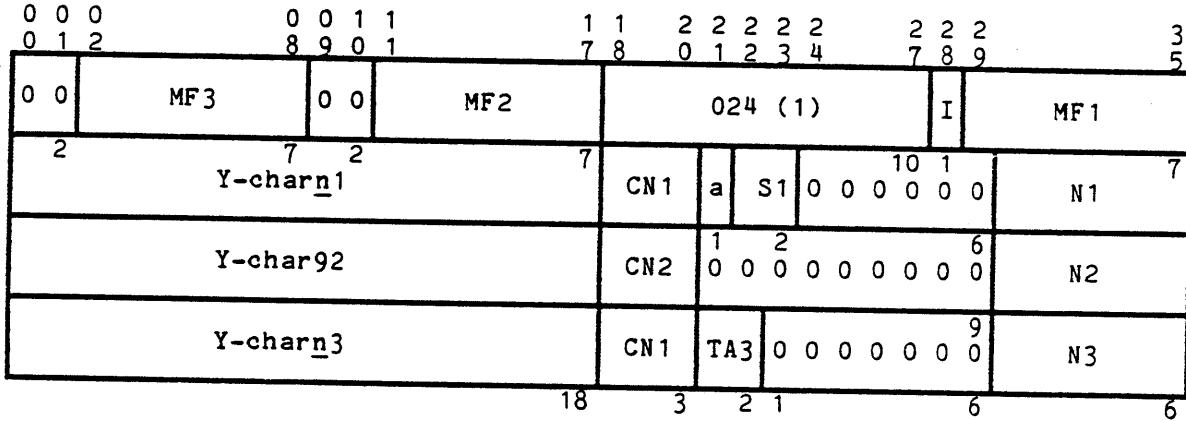

Figure 4-22. Move Numeric Edited (mvne) EIS Multiword Instruction Format

key

- MF1 Modification field for operand descriptor 1
- MF2 Modification field for operand descriptor 2
- MF3 Modification field for operand descriptor 3
- I Interrupt inhibit bit
- Y-charn₁ Address of sending string
- CN1 First character position of sending string
- a TN1 Data type of sending string
- S1 Sign and decimal type of sending string
- N1 Length of sending string
- Y-char92 Address of MOP control string
- CN2 First character position of MOP control string
- N2 Length of MOP control string
- Y-charn₃ Address of receiving string
- CN3 First character position of receiving string
- TA3 Data type of receiving string
- N3 Length of receiving string

ALM Coding Format:

mvne	(MF1),(MF2),(MF3)	
descn[fl,ls,ns,ts]	Y-charn1[(CN1)],N1	<u>n</u> = 4 or 9
desc9a	Y-char92[(CN2)],N2	
descna	Y-charn3[(CN3)],N3	<u>n</u> = 4, 6, or 9

SUMMARY: C(Y-charn1) -> C(Y-charn3) under C(Y_char92) MOP control

See "Micro Operations for Edit Instructions" later in this section for details of editing under MOP control.

MODIFICATIONS: None except au, qu, al, ql, xn for MF1, MF2, and MF3

INDICATORS: None affected

NOTES: If data types are dissimilar (TA1 ≠ TA3), each character of C(Y-charn1) is high-order truncated or zero filled, as appropriate, as it is moved. No character conversion takes place.

If the data type of the receiving string is not 9-bit (TA3 ≠ 0), then insertion characters are high-order truncated as they are inserted.

The maximum string length is 63. The count fields N1, N2, and N3 are treated as modulo 64 numbers.

The instruction completes normally only if N3 is the first tally to exhaust: otherwise, an illegal procedure fault occurs.

If MFk.RL = 1, then Nk does not contain the operand length; instead, it contains a register code for a register holding the operand length.

If MFk.ID = 1, then the kth word following the instruction word does not contain an operand descriptor; instead, it contains an indirect pointer to the operand descriptor.

C(Y-charn1) and C(Y-charn3) may be overlapping strings; no check is made. This feature is useful for replication of substrings within a larger string, but care must be exercised in the construction of the operand descriptors so that sending string, C(Y-charn1), data is not inadvertently destroyed.

The user of string replication or overlaying is warned that the decimal unit addresses the main memory in unaligned (not on modulo 8 boundary) units of Y-block8 words and that the overlaid string, C(Y-charn3), is not returned to main memory until the unit of Y-block8 words is filled or the instruction completes.

Attempted execution with the xed instruction causes an illegal procedure fault.

Attempted repetition with the rpt, rpd, or rpl instructions causes an illegal procedure fault.

EIS - BIT STRING COMBINE

EIS - Bit String Combine

csl	Combine Bit Strings Left	060 (1)
-----	--------------------------	---------

FORMAT:

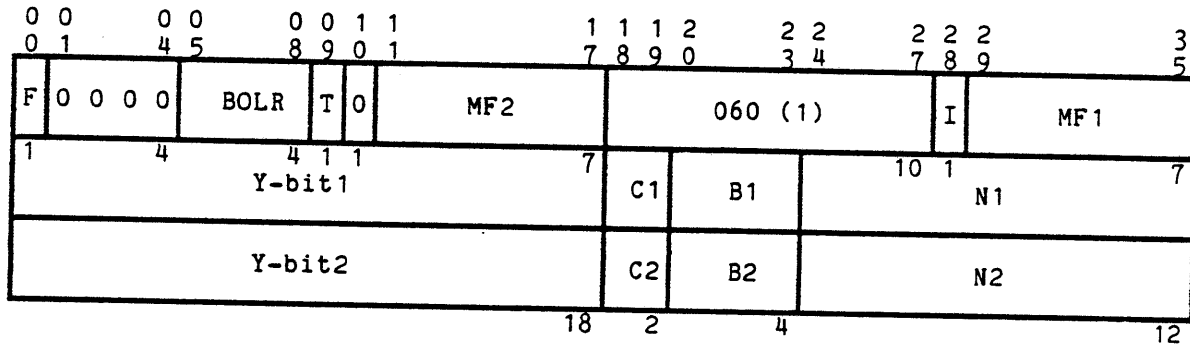

Figure 4-23. Combine Bit Strings Left (csl) EIS Multiword Instruction Format

- F Fill bit for string extension
- BOLR Boolean result control field
- T Truncation fault enable bit
- MF1 Modification field for operand descriptor 1
- MF2 Modification field for operand descriptor 2
- I Interrupt inhibit bit
- Y-bit1 Address of sending string
- C1 First character position of sending string
- B1 First bit position of sending string
- N1 Length of sending string
- Y-bit2 Address of receiving string
- C2 First character position of receiving string
- B2 First bit position of receiving string
- N2 Length of receiving string

ALM Coding Format:

```

csl      (MF1),(MF2)[,enablefault][,bool(octalexpression)][,fill(0;1)]
descb   Y-bit1[(BITNO1)],N1
descb   Y-bit2[(BITNO2)],N2
    
```

SUMMARY: For $i = \text{bits } 1, 2, \dots, \text{minimum } (N1, N2)$
 $m = C(\text{Y-bit1})_{i-1} \text{ !! } C(\text{Y-bit2})_{i-1}$ (a 2-bit number)
 $C(\text{BOLR})_m \rightarrow C(\text{Y-bit2})_{i-1}$
 If $N1 < N2$, then for $i = N1+1, N1+2, \dots, N2$
 $m = C(F) \text{ !! } C(\text{Y-bit2})_{i-1}$ (a 2-bit number)
 $C(\text{BOLR})_m \rightarrow C(\text{Y-bit2})_{i-1}$

MODIFICATIONS: None except au, qu, al, ql, x_n for MF1 and MF2

INDICATORS: (Indicators not listed are not affected)

Zero If $C(\text{Y-bit2}) = 00\dots 0$, then ON; otherwise OFF
 Truncation If $N1 > N2$, then ON; otherwise OFF

NOTES: If $N1 > N2$, the low order $(N1-N2)$ bits of $C(\text{Y-bit1})$ are not processed and the truncation indicator is set ON.

The bit pattern in $C(\text{BOLR})$ defines the Boolean operation to be performed. Any of the sixteen possible Boolean operations may be used. Some common Boolean operations and their BOLR fields are shown below.

<u>Operation</u>	<u>C(BOLR)</u>
MOVE	0011
AND	0001
OR	0111
NAND	1110
EXCLUSIVE OR	0110
Clear	0000
Invert	1100

If $MFk.RL = 1$, then N_k does not contain the operand length; instead, it contains a register code for a register holding the operand length.

If $MFk.ID = 1$, then the k th word following the instruction word does not contain an operand descriptor; instead, it contains an indirect pointer to the operand descriptor.

$C(\text{Y-bit1})$ and $C(\text{Y-bit2})$ may be overlapping strings; no check is made. This feature is useful for replication of substrings within a larger string, but care must be exercised in the construction of the operand descriptors so that sending string, $C(\text{Y-bit1})$, data is not inadvertently destroyed.

The user of string replication or overlaying is warned that the decimal unit addresses the main memory in unaligned (not on modulo 8 boundary) units of Y-block8 words and that the overlaid string, C(Y-bit2), is not returned to main memory until the unit of Y-block8 words is filled or the instruction completes.

If T = 1 and the truncation indicator is set ON by execution of the instruction, then a truncation (overflow) fault occurs.

Attempted execution with the xed instruction causes an illegal procedure fault.

Attempted repetition with the rpt, rpd, or rpl instructions causes an illegal procedure fault.

csr	Combine Bit Strings Right	061 (1)
-----	---------------------------	---------

FORMAT: Same as Combine Bit Strings Left (csl) (see Figure 4-23).

SUMMARY: For $i = \text{bits } 1, 2, \dots, \text{minimum}(N1, N2)$

$$m = C(\text{Y-bit1})_{N1-i} \parallel C(\text{Y-bit2})_{N2-i} \quad (\text{a 2-bit number})$$

$$C(\text{BOLR})_m \rightarrow C(\text{Y-bit2})_{N2-i}$$

If $N1 < N2$, then for $i = N1+1, N1+2, \dots, N2$

$$m = C(F) \parallel C(\text{Y-bit2})_{N2-i} \quad (\text{a 2-bit number})$$

$$C(\text{BOLR})_m \rightarrow C(\text{Y-bit2})_{N2-i}$$

MODIFICATIONS: None except au, qu, al, ql, xn for MF1 and MF2

INDICATORS: (Indicators not listed are not affected)

Zero If $C(\text{Y-bit2}) = 00\dots 0$, then ON; otherwise OFF

Truncation If $N1 > N2$, then ON; otherwise OFF

NOTES: If $N1 > N2$, the high order $(N1-N2)$ bits of C(Y-bit1) are not processed and the truncation indicator is set ON.

The bit pattern in C(BOLR) defines the Boolean operation to be performed. Any of the sixteen possible Boolean operations may be used. See NOTES under the Combine Bit Strings Left (csl) instruction for examples of BOLR.

If $\text{MFk.RL} = 1$, then N_k does not contain the operand length; instead, it contains a register code for a register holding the operand length.

If $MF_k.ID = 1$, then the k th word following the instruction word does not contain an operand descriptor; instead, it contains an indirect pointer to the operand descriptor.

$C(Y\text{-bit}1)$ and $C(Y\text{-bit}2)$ may be overlapping strings; no check is made. This feature is useful for replication of substrings within a larger string, but care must be exercised in the construction of the operand descriptors so that sending string, $C(Y\text{-bit}1)$, data is not inadvertently destroyed.

The user of string replication or overlaying is warned that the decimal unit addresses the main memory in unaligned (not on modulo 8 boundary) units of Y-block8 words and that the overlaid string, $C(Y\text{-bit}2)$, is not returned to main memory until the unit of Y-block8 words is filled or the instruction completes.

If $T = 1$ and the truncation indicator is set ON by execution of the instruction, then a truncation (overflow) fault occurs.

Attempted execution with the xed instruction causes an illegal procedure fault.

Attempted repetition with the rpt, rpd, or rpl instructions causes an illegal procedure fault.

EIS - BIT STRING COMPARE

EIS - Bit String Compare

cmpb	Compare Bit Strings	066 (1)
------	---------------------	---------

FORMAT:

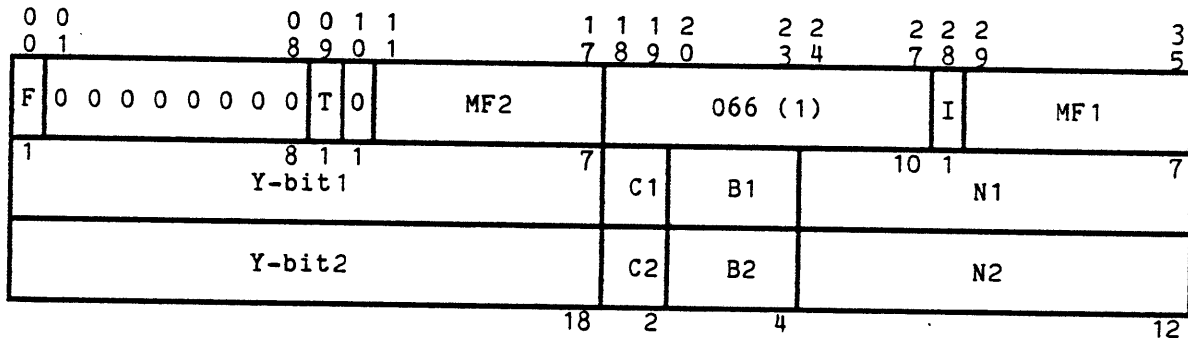

Figure 4-24. Compare Bit Strings (cmpb) EIS Multiword Instruction Format

- F Fill bit for string extension
- T Truncation fault enable bit
- MF1 Modification field for operand descriptor 1
- MF2 Modification field for operand descriptor 2
- I Interrupt inhibit bit
- Y-bit1 Address of left-hand string
- C1 First character position of left-hand string
- B1 First bit position of left-hand string
- N1 Length of left-hand string
- Y-bit2 Address of right-hand string
- C2 First character position of right-hand string
- B2 First bit position of right-hand string
- N2 Length of right-hand string

ALM Coding Format:

```

cmpb   (MF1),(MF2)[,enablefault][,fill(0|1)]
descb  Y-bit1[(BITNO1)],N1
descb  Y-bit2[(BITNO2)],N2
    
```

SUMMARY: For i = 1, 2, ..., minimum (N1,N2)

$$C(Y\text{-bit1})_{i-1} :: C(Y\text{-bit2})_{i-1}$$

If $N1 < N2$, then for $i = N1+1, N1+2, \dots, N2$

$$C(\text{FILL}) :: C(Y\text{-bit2})_{i-1}$$

If $N1 > N2$, then for $i = N2+1, N2+2, \dots, N1$

$$C(Y\text{-bit1})_{i-1} :: C(\text{FILL})$$

MODIFICATIONS: None except au, qu, al, ql, x_n for MF1 and MF2

INDICATORS: (Indicators not listed are not affected)

Zero If $C(Y\text{-bit1})_i = C(Y\text{-bit2})_i$ for all i , then ON;
otherwise, OFF

Carry If $C(Y\text{-bit1})_i < C(Y\text{-bit2})_i$ for any i , then OFF;
otherwise ON

NOTES: Instruction execution proceeds until an inequality is found or the larger string length count is exhausted.

If $MF_k.RL = 1$, then N_k does not contain the operand length; instead, it contains a register code for a register holding the operand length.

If $MF_k.ID = 1$, then the k th word following the instruction word does not contain an operand descriptor; instead, it contains an indirect pointer to the operand descriptor.

Attempted execution with the xed instruction causes an illegal procedure fault.

Attempted repetition with the $rpt, rpd,$ or rpl instructions causes an illegal procedure fault.

EIS - Bit String Set Indicators

sztl	Set Zero and Truncation Indicators with Bit Strings Left	064 (1)
------	--	---------

FORMAT: Same as Combine Bit Strings Left (csl) (see Figure 4-23).

SUMMARY: For $i = \text{bits } 1, 2, \dots, \text{minimum } (N1, N2)$
 $m = C(Y\text{-bit}1)_{i-1} \parallel C(Y\text{-bit}2)_{i-1}$ (a 2-bit number)
 If $C(\text{BOLR})_m \neq 0$, then terminate
 If $N1 < N2$, then for $i = N1+1, N1+2, \dots, N2$
 $m = C(F) \parallel C(Y\text{-bit}2)_{i-1}$ (a 2-bit number)
 If $C(\text{BOLR})_m \neq 0$, then terminate

MODIFICATIONS: None except au, qu, al, ql, x_n for MF1 and MF2

INDICATORS: (Indicators not listed are not affected)

Zero If $C(\text{BOLR})_m = 0$ for all i , then ON; otherwise OFF

Truncation If $N1 > N2$, then ON; otherwise OFF

NOTES: If $N1 > N2$, the low order $(N1-N2)$ bits of $C(Y\text{-bit}1)$ are not processed and the truncation indicator is set ON.

The execution of this instruction is identical to the Combine Bit Strings Left (csl) instruction except that $C(\text{BOLR})_m$ is not placed into $C(Y\text{-bit}2)_{i-1}$.

The bit pattern in $C(\text{BOLR})$ defines the Boolean operation to be performed. Any of the sixteen possible Boolean operations may be used. See NOTES under the Combine Bit Strings Left (csl) instruction for examples of BOLR.

If $\text{MFk.RL} = 1$, then N_k does not contain the operand length; instead, it contains a register code for a register holding the operand length.

If $\text{MFk.ID} = 1$, then the k th word following the instruction word does not contain an operand descriptor; instead, it contains an indirect pointer to the operand descriptor.

If $T = 1$ and the truncation indicator is set ON by execution of the instruction, then a truncation (overflow) fault occurs.

Attempted execution with the xed instruction causes an illegal procedure fault.

Attempted repetition with the rpt, rpd, or rpl instructions causes an illegal procedure fault.

sztr	Set Zero and Truncation Indicators with Bit Strings Right	065 (1)
------	---	---------

FORMAT: Same as Combine Bit Strings Left (csl) (see Figure 4-23).

SUMMARY: For $i = \text{bits } 1, 2, \dots, \text{minimum}(N1, N2)$
 $m = C(\text{Y-bit}1)_{N1-i} \text{ || } C(\text{Y-bit}2)_{N2-i}$ (a 2-bit number)
 If $C(\text{BOLR})_m \neq 0$, then terminate
 If $N1 < N2$, then for $i = N1+1, N1+2, \dots, N2$
 $m = C(F) \text{ || } C(\text{Y-bit}2)_{N2-i}$ (a 2-bit number)
 If $C(\text{BOLR})_m \neq 0$, then terminate

MODIFICATIONS: None except au, qu, al, ql, x_n for MF1 and MF2

INDICATORS: (Indicators not listed are not affected)

Zero If $C(\text{BOLR})_m = 0$ for all i , then ON; otherwise OFF

Truncation If $N1 > N2$, then ON; otherwise OFF

NOTES: If $N1 > N2$, the low order $(N1-N2)$ bits of $C(\text{Y-bit}1)$ are not processed and the truncation indicator is set ON.

The execution of this instruction is identical to the Combine Bit Strings Right (csr) instruction except that $C(\text{BOLR})_m$ is not placed into $C(\text{Y-bit}2)_{N2-i}$.

The bit pattern in $C(\text{BOLR})$ defines the Boolean operation to be performed. Any of the sixteen possible Boolean operations may be used. See NOTES under the Combine Bit Strings Left (csl) instruction for examples of BOLR.

If $\text{MFk.RL} = 1$, then N_k does not contain the operand length; instead, it contains a register code for a register holding the operand length.

If $\text{MFk.ID} = 1$, then the k th word following the instruction word does not contain an operand descriptor; instead, it contains an indirect pointer to the operand descriptor.

If $T = 1$ and the truncation indicator is set ON by execution of the instruction, then a truncation (overflow) fault occurs.

Attempted execution with the xed instruction causes an illegal procedure fault.

Attempted repetition with the rpt, rpd, or rpl instructions causes an illegal procedure fault.

EIS - BIT STRING SET INDICATORS

EIS - Data Conversion

btd	Binary to Decimal Convert	301 (1)
-----	---------------------------	---------

FORMAT:

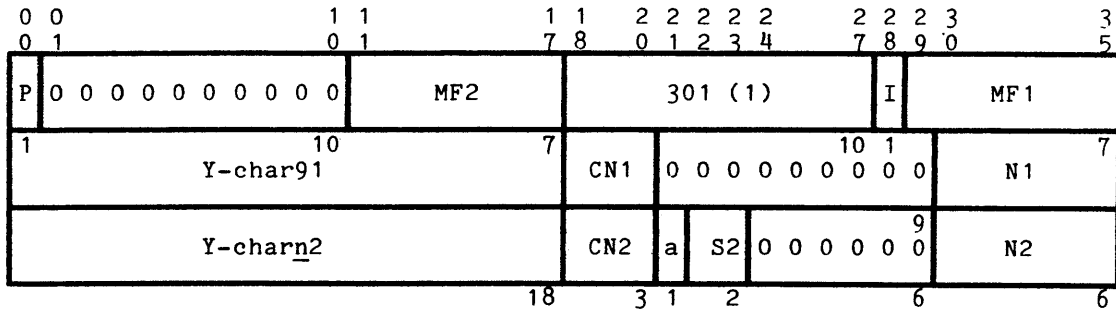

Figure 4-25. Binary to Decimal Convert (BTD) EIS Multiword Instruction Format

key

- P 4-bit data sign character control
- MF1 Modification field for operand descriptor 1
- MF2 Modification field for operand descriptor 2
- I Interrupt inhibit bit
- Y-char₉₁ Address of binary number
- CN1 First byte position of binary number
- N1 Length of binary number in 9-bit bytes
- Y-char_{n2} Address of decimal number
- CN2 First character position of decimal number
- a TN2 Data type of decimal number
- S2 Sign and decimal type of decimal number
- N2 Length of decimal number

ALM Coding Format:

btd (MF1),(MF2)
 desc_{9a} Y-char₉₁[(CN1)],N1
 desc_n[ls,ns,ts] Y-char_{n2}[(CN2)],N2 n = 4 or 9

SUMMARY: C(Y-char₉₁) converted to decimal -> C(Y-char_{n2})

EIS - DATA CONVERSION

MODIFICATIONS: None except au, qu, al, ql, xn for MF1 ad MF2

INDICATORS: (Indicators not listed are not affected)

Zero	If C(Y-charn2) = decimal 0, then ON; otherwise OFF
Negative	If a minus sign character is moved to C(Y-charn2), then ON; otherwise OFF
Overflow	If fixed-point integer overflow occurs, then ON; otherwise unchanged (see NOTES)

NOTES: C(Y-char91) contains a twos complement binary integer aligned on 9-bit character boundaries with length $0 < N1 \leq 8$.

If TN2 and S2 specify a 4-bit signed number and P = 1, then if C(Y-char91) is positive (bit 0 of C(Y-char91)₀ = 0), then the 13₈ plus sign character is moved to C(Y-charn2) as appropriate.

The scaling factor of C(Y-charn2), SF2, must be 0.

If N2 is not large enough to hold the digits generated by conversion of C(Y-char91) an overflow condition exists; the overflow indicator is set ON and an overflow fault occurs. This implies that an unsigned fixed-point receiving field has a minimum length of 1 character and a signed fixed-point field, 2 characters.

If MFk.RL = 1, then Nk does not contain the operand length; instead, it contains a register code for a register holding the operand length.

If MFk.ID = 1, then the kth word following the instruction word does not contain an operand descriptor; instead, it contains an indirect pointer to the operand descriptor.

C(Y-char91) and C(Y-charn2) may be overlapping strings; no check is made.

Attempted conversion to a floating-point number (S2 = 0) or attempted use of a scaling factor (SF2 ≠ 0) causes an illegal procedure fault.

If N1 = 0 or N1 > 8 an illegal procedure fault occurs.

Attempted execution with the xed instruction causes an illegal procedure fault.

Attempted repetition with the rpt, rpd, or rpl instructions causes an illegal procedure fault.

dtb	Decimal to Binary Convert	305 (1)
-----	---------------------------	---------

FORMAT:

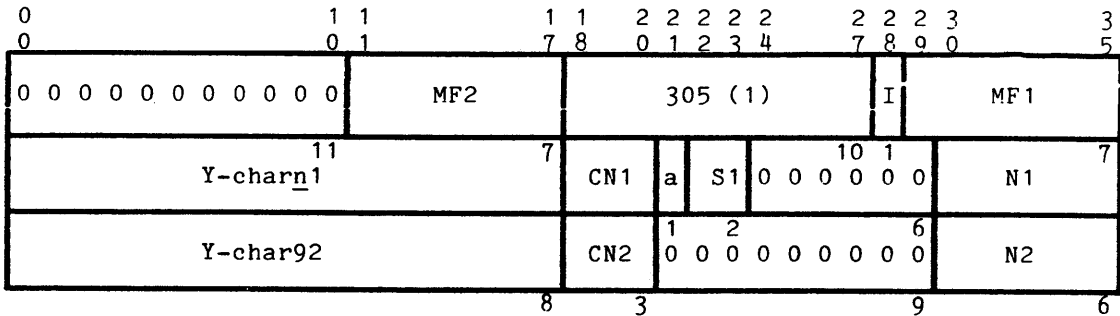

Figure 4-26. Decimal to Binary Convert (dtb) EIS Multiword Instruction Format

key

- MF1 Modification field for operand descriptor 1
- MF2 Modification field for operand descriptor 2
- I Interrupt inhibit bit
- Y-char_n1 Address of decimal number
- CN1 First character position of decimal number
- a Data type of decimal number
- S1 Sign and decimal type of decimal number
- N1 Length of decimal number
- Y-char_n2 Address of binary number
- CN2 First byte position of binary number
- N2 Length of binary number in 9-bit bytes

ALM Coding Format:

dtb	(MF1),(MF2)	
desc _n [ls,ns,ts]	Y-char _n 1[(CN1)],N1	<u>n</u> = 4 or 9
desc9a	Y-char92[(CN2)],N2	

SUMMARY: C(Y-char_n1) converted to binary -> C(Y-char92)

MODIFICATIONS: None except au, qu, al, ql, x_n for MF1 ad MF2

INDICATORS: (Indicators not listed are not affected)

Zero If $C(Y\text{-char92}) = 0$, then ON; otherwise OFF

Negative If a minus sign character is found in $C(Y\text{-charn1})$, then ON; otherwise OFF

Overflow If fixed-point integer overflow occurs, then ON; otherwise unchanged (see NOTES)

NOTES:

$C(Y\text{-char92})$ will contain a twos complement binary integer aligned on 9-bit byte boundaries with length $0 < N2 \leq 8$.

The scaling factor of $C(Y\text{-charn1})$, $SF1$, must be 0.

If $N2$ is not large enough to hold the converted value of $C(Y\text{-charn1})$ an overflow condition exists; the overflow indicator is set ON and an overflow fault occurs.

If $MFk.RL = 1$, then Nk does not contain the operand length; instead, it contains a register code for a register holding the operand length.

If $MFk.ID = 1$, then the k th word following the instruction word does not contain an operand descriptor; instead, it contains an indirect pointer to the operand descriptor.

$C(Y\text{-charn1})$ and $C(Y\text{-char92})$ may be overlapping strings; no check is made.

Attempted conversion of a floating-point number ($S1 = 0$) or attempted use of a scaling factor ($SF1 \neq 0$) causes an illegal procedure fault.

If $N2 = 0$ or $N2 > 8$ an illegal procedure fault occurs.

Attempted execution with the `xed` instruction causes an illegal procedure fault.

Attempted repetition with the `rpt`, `rpd`, or `rpl` instructions causes an illegal procedure fault.

EIS - DECIMAL ADDITION

EIS - Decimal Addition

ad2d	Add Using Two Decimal Operands	202 (1)
------	--------------------------------	---------

FORMAT:

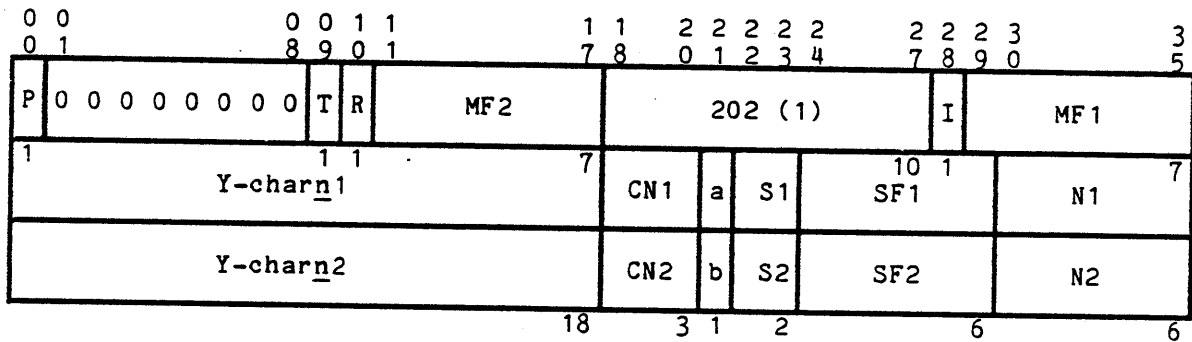

Figure 4-27. Add Using Two Decimal Operands (ad2d) EIS Multiword Instruction Format

key

- P 4-bit data sign character control
- T Truncation fault enable bit
- R Rounding flag
- MF1 Modification field for operand descriptor 1
- MF2 Modification field for operand descriptor 2
- I Interrupt inhibit bit
- Y-charn₁ Address of augend (ad2d), minuend (sb2d), multiplicand (mp2d), or divisor (dv2d)
- CN1 First character position of augend (ad2d), minuend (sb2d), multiplicand (mp2d), or divisor (dv2d)
- a TN1 Data type of augend (ad2d), minuend (sb2d), multiplicand (mp2d), or divisor (dv2d)
- S1 Sign and decimal type of augend (ad2d), minuend (sb2d), multiplicand (mp2d), or divisor (dv2d)
- SF1 Scaling factor of augend (ad2d), minuend (sb2d), multiplicand (mp2d), or divisor (dv2d)
- N1 Length of augend (ad2d), minuend (sb2d), multiplicand (mp2d), or divisor (dv2d)
- Y-charn₂ Address of addend and sum (ad2d), subtrahend and difference (sb2d), multiplier and product (mp2d), or dividend and quotient (dv2d)

- CN2 First character position of addend and sum (ad2d), subtrahend and difference (sb2d), multiplier and product (mp2d), or dividend and quotient (dv2d)
- b TN2 Data type of addend and sum (ad2d), subtrahend and difference (sb2d), multiplier and product (mp2d), or dividend and quotient (dv2d)
- S2 Sign and decimal type of addend and sum (ad2d), subtrahend and difference (sb2d), multiplier and product (mp2d), or dividend and quotient (dv2d)
- SF2 Scaling factor of addend and sum (ad2d), subtrahend and difference (sb2d), multiplier and product (mp2d), or dividend and quotient (dv2d)
- N2 Length of addend and sum (ad2d), subtrahend and difference (sb2d), multiplier and product (mp2d), or dividend and quotient (dv2d)

ALM Coding Format:

```

ad2d                (MF1),(MF2)[,enablefault][,round]
descn[f1,ls,ns,ts] Y-charn1[(CN1)],N1,SF1      n = 4 or 9
descn[f1,ls,ns,ts] Y-charn2[(CN2)],N2,SF2     n = 4 or 9
    
```

SUMMARY: C(Y-charn₁) + C(Y-charn₂) -> C(Y-charn₂)

MODIFICATIONS: None except au, qu, al, ql, x_n for MF1 and MF2

INDICATORS: (Indicators not listed are not affected)

- Zero If C(Y-charn₂) = decimal 0, then ON; otherwise OFF
- Negative If C(Y-charn₂) is negative, then ON; otherwise OFF
- Truncation If the truncation condition exists without rounding, then ON; otherwise OFF see NOTES)
- Overflow If the overflow condition exists, then ON; otherwise unchanged (see NOTES)
- Exponent overflow If exponent of floating-point result exceeds 127 then ON; otherwise unchanged.
- Exponent underflow If exponent of floating-point result is less than -128 then ON; otherwise unchanged

NOTES: If TN2 and S2 specify a 4-bit signed number and P = 1, then the 13_g plus sign character is placed appropriately if the result of the operation is positive.

If N2 is not large enough to hold the integer part of the result as scaled by SF2, an overflow condition exists; the overflow indicator is set ON and an overflow fault occurs. This implies that an unsigned fixed-point receiving field has a minimum length of 1 character; a signed fixed-point field, 2 characters; and a floating-point field, 3 characters.

If N_2 is not large enough to hold all the digits of the result as scaled by SF_2 and $R = 0$, then a truncation condition exists; data movement stops when $C(Y\text{-char}_2)$ is filled and the truncation indicator is set ON. If $\bar{R} = 1$, then the last digit moved is rounded according to the absolute value of the remaining digits of the result and the instruction completes normally.

If $MF_k.RL = 1$, then N_k does not contain the operand length; instead, it contains a register code for a register holding the operand length.

If $MF_k.ID = 1$, then the k th word following the instruction word does not contain an operand descriptor; instead, it contains an indirect pointer to the operand descriptor.

$C(Y\text{-char}_1)$ and $C(Y\text{-char}_2)$ may be overlapping strings; no check is made.

If $T = 1$ and the truncation indicator is set ON by execution of the instruction, then a truncation (overflow) fault occurs.

Detection of a character outside the range $[0,11]_8$ in a digit position or a character outside the range $[12,17]_8$ in a sign position causes an illegal procedure fault.

Attempted execution with the `xed` instruction causes an illegal procedure fault.

Attempted repetition with the `rpt`, `rpd`, or `rpl` instructions causes an illegal procedure fault.

ad3d	Add Using Three Decimal Operands	222 (1)
------	----------------------------------	---------

FORMAT:

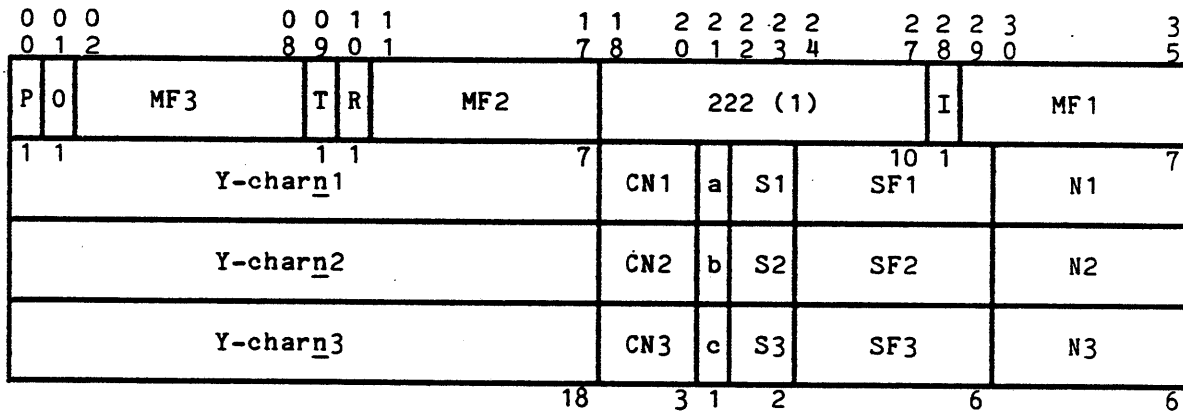

Figure 4-28. Add Using Three Decimal Operands (ad3d) EIS Multiword Instruction Format

key

- P 4-bit data sign character control
- T Truncation fault enable bit
- R Rounding flag
- MF1 Modification field for operand descriptor 1
- MF2 Modification field for operand descriptor 2
- MF3 Modification field for operand descriptor 3
- I Interrupt inhibit bit
- Y-charn₁ Address of augend (ad3d), minuend (sb3d), multiplicand (mp3d), or divisor (dv3d)
- CN1 First character position of augend (ad3d), minuend (sb3d), multiplicand (mp3d), or divisor (dv3d)
- a TN1 Data type of augend (ad3d), minuend (sb3d), multiplicand (mp3d), or divisor (dv3d)
- S1 Sign and decimal type of augend (ad3d), minuend (sb3d), multiplicand (mp3d), or divisor (dv3d)
- SF1 Scaling factor of augend (ad3d), minuend (sb3d), multiplicand (mp3d), or divisor (dv3d)
- N1 Length of augend (ad3d), minuend (sb3d), multiplicand (mp3d), or divisor (dv3d)
- Y-charn₂ Address of addend (ad3d), subtrahend (sb3d), multiplier (mp3d), or dividend (dv3d)

EIS - DECIMAL ADDITION

CN2	First character position of addend (ad3d), subtrahend (sb3d), multiplier (mp3d), or dividend (dv3d)
b TN2	Data type of addend (ad3d), subtrahend (sb3d), multiplier (mp3d), or dividend (dv3d)
S2	Sign and decimal type of addend (ad3d), subtrahend (sb3d), multiplier (mp3d), or dividend (dv3d)
SF2	Scaling factor of addend (ad3d), subtrahend (sb3d), multiplier (mp3d), or dividend (dv3d)
N2	Length of addend (ad3d), subtrahend (sb3d), multiplier (mp3d), or dividend (dv3d)
Y-charn3	Address of sum (ad3d), difference (sb3d), product (mp3d), or quotient (dv3d)
CN3	First character position of sum (ad3d), difference (sb3d), product (mp3d), or quotient (dv3d)
c TN3	Data type of sum (ad3d), difference (sb3d), product (mp3d), or quotient (dv3d)
S3	Sign and decimal type of sum (ad3d), difference (sb3d), product (mp3d), or quotient (dv3d)
SF3	Scaling factor of sum (ad3d), difference (sb3d), product (mp3d), or quotient (dv3d)
N3	Length of sum (ad3d), difference (sb3d), product (mp3d), or quotient (dv3d)

ALM Coding Format:

ad3d	(MF1),(MF2),(MF3)[,enablefault][,round]
descn[f1,ls,ns,ts]	Y-charn1[(CN1)],N1,SF1 $\frac{n}{n} = 4 \text{ or } 9$
descn[f1,ls,ns,ts]	Y-charn2[(CN2)],N2,SF2 $\frac{n}{n} = 4 \text{ or } 9$
descn[f1,ls,ns,ts]	Y-charn3[(CN3)],N3,SF3 $\frac{n}{n} = 4 \text{ or } 9$

SUMMARY: C(Y-charn1) + C(Y-charn2) -> C(Y-charn3)

MODIFICATIONS: None except au, qu, al, ql, xn for MF1 and MF2

INDICATORS: (Indicators not listed are not affected)

Zero	If C(Y-charn3) = decimal 0, then ON; otherwise OFF
Negative	If C(Y-charn3) is negative, then ON; otherwise OFF
Truncation	If the truncation condition exists without rounding, then ON; otherwise OFF (see NOTES)
Overflow	If the overflow condition exists, then ON; otherwise unchanged (see NOTES)
Exponent overflow	If exponent of floating-point result exceeds 127 then ON; otherwise unchanged.

Exponent If exponent of floating-point result is less than -128
underflow then ON; otherwise unchanged

- NOTES:
- If TN_3 and S_3 specify a 4-bit signed number and $P = 1$, then the 13_8 plus sign character is placed appropriately if the result of the operation is positive.
- If N_3 is not large enough to hold the integer part of the result as scaled by SF_3 , an overflow condition exists; the overflow indicator is set ON and an overflow fault occurs. This implies that an unsigned fixed-point receiving field has a minimum length of 1 character; a signed fixed-point field, 2 characters; and a floating-point field, 3 characters.
- If N_3 is not large enough to hold all the digits of the result as scaled by SF_3 and $R = 0$, then a truncation condition exists; data movement stops when $C(Y\text{-char}_3)$ is filled and the truncation indicator is set ON. If $\bar{R} = 1$, then the last digit moved is rounded according to the absolute value of the remaining digits of the result and the instruction completes normally.
- If $MF_k.RL = 1$, then N_k does not contain the operand length; instead, it contains a register code for a register holding the operand length.
- If $MF_k.ID = 1$, then the k th word following the instruction word does not contain an operand descriptor; instead, it contains an indirect pointer to the operand descriptor.
- $C(Y\text{-char}_1)$, $C(Y\text{-char}_2)$, and $C(Y\text{-char}_3)$ may be overlapping strings; no check is made.
- If $T = 1$ and the truncation indicator is set ON by execution of the instruction, then a truncation (overflow) fault occurs.
- Detection of a character outside the range $[0,11]_8$ in a digit position or a character outside the range $[12,17]_8$ in a sign position causes an illegal procedure fault.
- Attempted execution with the xed instruction causes an illegal procedure fault.
- Attempted repetition with the rpt , rpd , or rpl instructions causes an illegal procedure fault.

EIS - Decimal Subtraction

sb2d	Subtract Using Two Decimal Operands	203 (1)
------	-------------------------------------	---------

FORMAT: Same as Add Using Two Decimal Operands (ad2d)
(see Figure 4-27).

SUMMARY: $C(Y\text{-char}_1) - C(Y\text{-char}_2) \rightarrow C(Y\text{-char}_2)$

MODIFICATIONS: None except au, qu, al, ql, x_n for MF1 and MF2

INDICATORS: (Indicators not listed are not affected)

Zero If $C(Y\text{-char}_2) = \text{decimal } 0$, then ON; otherwise OFF

Negative If $C(Y\text{-char}_2)$ is negative, then ON; otherwise OFF

Truncation If the truncation condition exists without rounding, then ON; otherwise OFF (see NOTES)

Overflow If the overflow condition exists, then ON; otherwise unchanged (see NOTES)

Exponent overflow If exponent of floating-point result exceeds 127 then ON; otherwise unchanged.

Exponent underflow If exponent of floating-point result is less than -128 then ON; otherwise unchanged

NOTES: If TN2 and S2 specify a 4-bit signed number and $P = 1$, then the 13_g plus sign character is placed appropriately if the result of the operation is positive.

If N2 is not large enough to hold the integer part of the result as scaled by SF2, an overflow condition exists; the overflow indicator is set ON and an overflow fault occurs. This implies that an unsigned fixed-point receiving field has a minimum length of 1 character; a signed fixed-point field, 2 characters; and a floating-point field, 3 characters.

If N2 is not large enough to hold all the digits of the result as scaled by SF2 and $R = 0$, then a truncation condition exists; data movement stops when $C(Y\text{-char}_2)$ is filled and the truncation indicator is set ON. If $\bar{R} = 1$, then the last digit moved is rounded according to the absolute value of the remaining digits of the result and the instruction completes normally.

If $MF_k.RL = 1$, then N_k does not contain the operand length; instead, it contains a register code for a register holding the operand length.

If MF_k.ID = 1, then the kth word following the instruction word does not contain an operand descriptor; instead, it contains an indirect pointer to the operand descriptor.

C(Y-charn₁) and C(Y-charn₂) may be overlapping strings; no check is made.

If T = 1 and the truncation indicator is set ON by execution of the instruction, then a truncation (overflow) fault occurs.

Detection of a character outside the range [0,11]₈ in a digit position or a character outside the range [12,17]₈ in a sign position causes an illegal procedure fault.

Attempted execution with the xed instruction causes an illegal procedure fault.

Attempted repetition with the rpt, rpd, or rpl instructions causes an illegal procedure fault.

sb3d	Subtract Using Three Decimal Operands	223 (1)
------	---------------------------------------	---------

FORMAT: Same as Add Using Three Decimal Operands (ad3d) (see Figure 4-28).

SUMMARY: C(Y-charn₁) - C(Y-charn₂) -> C(Y-charn₃)

MODIFICATIONS: None except au, qu, al, ql, x_n for MF1 and MF2

INDICATORS: (Indicators not listed are not affected)

- Zero If C(Y-charn₃) = decimal 0, then ON; otherwise OFF
- Negative If C(Y-charn₃) is negative, then ON; otherwise OFF
- Truncation If the truncation condition exists without rounding, then ON; otherwise OFF (see NOTES)
- Overflow If the overflow condition exists, then ON; otherwise unchanged (see NOTES)
- Exponent overflow If exponent of floating-point result exceeds 127 then ON; otherwise unchanged.
- Exponent underflow If exponent of floating-point result is less than -128 then ON; otherwise unchanged

NOTES: If TN₃ and S₃ specify a 4-bit signed number and P = 1, then the 13₈ plus sign character is placed appropriately if the result of the operation is positive.

If N₃ is not large enough to hold the integer part of the result as scaled by SF₃, an overflow condition exists; the overflow indicator is set ON and an overflow fault

occurs. This implies that an unsigned fixed-point receiving field has a minimum length of 1 character; a signed fixed-point field, 2 characters; and a floating-point field, 3 characters.

If N_3 is not large enough to hold all the digits of the result as scaled by SF_3 and $R = 0$, then a truncation condition exists; data movement stops when $C(Y\text{-char}_3)$ is filled and the truncation indicator is set ON. If $\bar{R} = 1$, then the last digit moved is rounded according to the absolute value of the remaining digits of the result and the instruction completes normally.

If $MF_k.RL = 1$, then N_k does not contain the operand length; instead, it contains a register code for a register holding the operand length.

If $MF_k.ID = 1$, then the k th word following the instruction word does not contain an operand descriptor; instead, it contains an indirect pointer to the operand descriptor.

$C(Y\text{-char}_1)$, $C(Y\text{-char}_2)$, and $C(Y\text{-char}_3)$ may be overlapping strings; no check is made.

If $T = 1$ and the truncation indicator is set ON by execution of the instruction, then a truncation (overflow) fault occurs.

Detection of a character outside the range $[0,11]_8$ in a digit position or a character outside the range $[12,17]_8$ in a sign position causes an illegal procedure fault.

Attempted execution with the xed instruction causes an illegal procedure fault.

Attempted repetition with the rpt , rpd , or rpl instructions causes an illegal procedure fault.

EIS - Decimal Multiplication

mp2d	Multiply Using Two Decimal Operands	206 (1)
------	-------------------------------------	---------

FORMAT: Same as Add Using Two Decimal Operands (ad2d) (see Figure 4-27).

SUMMARY: $C(Y\text{-char}_1) \times C(Y\text{-char}_2) \rightarrow C(Y\text{-char}_2)$

MODIFICATIONS: None except au, qu, al, ql, xn for MF1 and MF2

INDICATORS: (Indicators not listed are not affected)

Zero If $C(Y\text{-char}_2) = \text{decimal } 0$, then ON; otherwise OFF

Negative If $C(Y\text{-char}_2)$ is negative, then ON; otherwise OFF

Truncation If the truncation condition exists without rounding, then ON; otherwise OFF (see NOTES)

Overflow If the overflow condition exists, then ON; otherwise unchanged (see NOTES)

Exponent overflow If exponent of floating-point result exceeds 127 then ON; otherwise unchanged.

Exponent underflow If exponent of floating-point result is less than -128 then ON; otherwise unchanged

NOTES:

If TN2 and S2 specify a 4-bit signed number and $P = 1$, then the 13₈ plus sign character is placed appropriately if the result of the operation is positive.

If N2 is not large enough to hold the integer part of the result as scaled by SF2, an overflow condition exists; the overflow indicator is set ON and an overflow fault occurs. This implies that an unsigned fixed-point receiving field has a minimum length of 1 character; a signed fixed-point field, 2 characters; and a floating-point field, 3 characters.

If N2 is not large enough to hold all the digits of the result as scaled by SF2 and $R = 0$, then a truncation condition exists; data movement stops when $C(Y\text{-char}_2)$ is filled and the truncation indicator is set ON. If $\bar{R} = 1$, then the last digit moved is rounded according to the absolute value of the remaining digits of the result and the instruction completes normally.

If $MF_k.RL = 1$, then N_k does not contain the operand length; instead, it contains a register code for a register holding the operand length.

EIS - DECIMAL MULTIPLICATION

If $MF_k.ID = 1$, then the k th word following the instruction word does not contain an operand descriptor; instead, it contains an indirect pointer to the operand descriptor.

$C(Y-charn_1)$ and $C(Y-charn_2)$ may be overlapping strings; no check is made.

If $T = 1$ and the truncation indicator is set ON by execution of the instruction, then a truncation (overflow) fault occurs.

Detection of a character outside the range $[0,11]_8$ in a digit position or a character outside the range $[12,17]_8$ in a sign position causes an illegal procedure fault.

Attempted execution with the xed instruction causes an illegal procedure fault.

Attempted repetition with the rpt, rpd, or rpl instructions causes an illegal procedure fault.

mp3d	Multiply Using Three Decimal Operands	226 (1)
------	---------------------------------------	---------

FORMAT: Same as Add Using Three Decimal Operands (ad3d) (see Figure 4-28).

SUMMARY: $C(Y-charn_1) \times C(Y-charn_2) \rightarrow C(Y-charn_3)$

MODIFICATIONS: None except au, qu, al, ql, x_n for MF1 and MF2

INDICATORS: (Indicators not listed are not affected)

Zero	If $C(Y-charn_3) = \text{decimal } 0$, then ON; otherwise OFF
Negative	If $C(Y-charn_3)$ is negative, then ON; otherwise OFF
Truncation	If the truncation condition exists without rounding, then ON; otherwise OFF (see NOTES)
Overflow	If the overflow condition exists, then ON; otherwise unchanged (see NOTES)
Exponent overflow	If exponent of floating-point result exceeds 127 then ON; otherwise unchanged.
Exponent underflow	If exponent of floating-point result is less than -128 then ON; otherwise unchanged

NOTES: If TN3 and S3 specify a 4-bit signed number and $P = 1$, then the 13_8 plus sign character is placed appropriately if the result of the operation is positive.

If N3 is not large enough to hold the integer part of the result as scaled by SF3, an overflow condition exists; the overflow indicator is set ON and an overflow fault

occurs. This implies that an unsigned fixed-point receiving field has a minimum length of 1 character; a signed fixed-point field, 2 characters; and a floating-point field, 3 characters.

If N_3 is not large enough to hold all the digits of the result as scaled by SF_3 and $R = 0$, then a truncation condition exists; data movement stops when $C(Y\text{-char}_3)$ is filled and the truncation indicator is set ON. If $\bar{R} = 1$, then the last digit moved is rounded according to the absolute value of the remaining digits of the result and the instruction completes normally.

If $MF_k.RL = 1$, then N_k does not contain the operand length; instead, it contains a register code for a register holding the operand length.

If $MF_k.ID = 1$, then the k th word following the instruction word does not contain an operand descriptor; instead, it contains an indirect pointer to the operand descriptor.

$C(Y\text{-char}_1)$, $C(Y\text{-char}_2)$, and $C(Y\text{-char}_3)$ may be overlapping strings; no check is made.

If $T = 1$ and the truncation indicator is set ON by execution of the instruction, then a truncation (overflow) fault occurs.

Detection of a character outside the range $[0,11]_8$ in a digit position or a character outside the range $[12,17]_8$ in a sign position causes an illegal procedure fault.

Attempted execution with the xed instruction causes an illegal procedure fault.

Attempted repetition with the rpt , rpd , or rpl instructions causes an illegal procedure fault.

EIS - Decimal Division

dv2d	Divide Using Two Decimal Operands	207 (1)
------	-----------------------------------	---------

FORMAT: Same as Add Using Two Decimal Operands (ad2d)
(see Figure 4-27).

SUMMARY: $C(Y\text{-char}_2) / C(Y\text{-char}_1) \rightarrow C(Y\text{-char}_2)$

MODIFICATIONS: None except au, qu, al, ql, x_n for MF1 and MF2

INDICATORS: (Indicators not listed are not affected)

* Zero If $C(Y\text{-char}_2) = \text{decimal } 0$, then ON; otherwise OFF

Negative If $C(Y\text{-char}_2)$ is negative, then ON; otherwise OFF

Overflow If the overflow condition exists, then ON; otherwise unchanged (see NOTES)

Exponent overflow If exponent of floating-point result exceeds 127 then ON; otherwise unchanged.

Exponent Underflow If exponent of floating-point result is less than -128 then ON; otherwise unchanged

NOTES: This instruction performs continued long division on the operands until it has produced enough output digits to satisfy the requirements of the quotient field. The number of required quotient digits, NQ, is determined before division begins as follows:

1) Floating-point quotient

$NQ = N2$, but if the divisor is greater than the dividend after operand alignment, the leading zero digit produced is counted and the effective precision of the result is reduced by one.

2) Fixed-point quotient

$$NQ = (N2 - LZ2 + 1) - (N1 - LZ1) + (E2 - E1 - SF2)$$

where: N_n = given operand field length
 LZ_n = leading zero count for operand n
 E_n = exponent of operand n
 $SF2$ = scaling factor of quotient

3) Rounding

If rounding is specified ($R = 1$), then one extra quotient digit is produced.

If $C(Y\text{-charn}_1) = \text{decimal } 0$ or $NQ > 63$, then division does not take place, $C(Y\text{-charn}_2)$ are unchanged, and a divide check fault occurs.

If TN_2 and S_2 specify a 4-bit signed number and $P = 1$, then the 13_8 plus sign character is placed appropriately if the result of the operation is positive.

If N_2 is not large enough to hold the integer part of the result as scaled by SF_2 , an overflow condition exists; the overflow indicator is set ON and an overflow fault occurs. This implies that an unsigned fixed-point receiving field has a minimum length of 1 character; a signed fixed-point field, 2 characters; and a floating-point field, 3 characters.

If N_2 is not large enough to hold all the digits of the result as scaled by SF_2 and $R = 0$, then a truncation condition exists; data movement stops when $C(Y\text{-charn}_2)$ is filled and the truncation indicator is set ON. If $\bar{R} = 1$, then the last digit moved is rounded according to the absolute value of the extra quotient digit and the instruction completes normally.

If $MF_k.RL = 1$, then N_k does not contain the operand length; instead, it contains a register code for a register holding the operand length.

If $MF_k.ID = 1$, then the k th word following the instruction word does not contain an operand descriptor; instead, it contains an indirect pointer to the operand descriptor.

$C(Y\text{-charn}_1)$ and $C(Y\text{-charn}_2)$ may be overlapping strings; no check is made.

Detection of a character outside the range $[0,11]_8$ in a digit position or a character outside the range $[12,17]_8$ in a sign position causes an illegal procedure fault. *

Attempted execution with the xed instruction causes an illegal procedure fault.

Attempted repetition with the rpt , rpd , or rpl instructions causes an illegal procedure fault.

dv3d	Divide Using Three Decimal Operands	227 (1)
------	-------------------------------------	---------

FORMAT: Same as Add Using Three Decimal Operands (ad3d) (see Figure 4-28).

SUMMARY: $C(Y\text{-charn}_2) / C(Y\text{-charn}_1) \rightarrow C(Y\text{-charn}_3)$

MODIFICATIONS: None except au , qu , al , ql , x_n for MF_1 and MF_2 .

INDICATORS: (Indicators not listed are not affected)

Zero	If C(Y-charn ₃) = decimal 0, then ON; otherwise OFF
Negative	If C(Y-charn ₃) is negative, then ON; otherwise OFF
Overflow	If the overflow condition exists, then ON; otherwise unchanged (see NOTES)
Exponent overflow	If exponent of floating-point result exceeds 127 then ON; otherwise unchanged.
Exponent underflow	If exponent of floating-point result is less than -128 then ON; otherwise unchanged

NOTES:

This instruction performs continued long division on the operands until it has produced enough output digits to satisfy the requirements of the quotient field. The number of required quotient digits, NQ, is determined before division begins as follows:

1) Floating-point quotient

$NQ = N3$, but if the divisor is greater than the dividend after operand alignment, the leading zero digit produced is counted and the effective precision of the result is reduced by one.

2) Fixed-point quotient

$$NQ = (N2 - LZ2 + 1) - (N1 - LZ1) + (E2 - E1 - SF3)$$

where: N_n = given operand field length
 LZ_n = leading zero count for operand n
 E_n = exponent of operand n
 $SF3$ = scaling factor of quotient

3) Rounding

If rounding is specified ($R = 1$), then one extra quotient digit is produced.

If C(Y-charn₁) = decimal 0 or $NQ > 63$, then division does not take place, C(Y-charn₃) are unchanged, and a divide check fault occurs.

If TN₃ and S₃ specify a 4-bit signed number and $P = 1$, then the 13_g plus sign character is placed appropriately if the result of the operation is positive.

If N₃ is not large enough to hold the integer part of the result as scaled by SF₃, an overflow condition exists; the overflow indicator is set ON and an overflow fault occurs. This implies that an unsigned fixed-point receiving field has a minimum length of 1 character; a signed fixed-point field, 2 characters; and a floating-point field, 3 characters.

If N₃ is not large enough to hold all the digits of the result as scaled by SF₃ and $R = 0$, then a truncation condition exists; data movement stops when C(Y-charn₃) is filled and the truncation indicator is set ON. If $\bar{R} = 1$, then the last digit moved is rounded according to the absolute value of the extra quotient digit and the instruction completes normally.

If $\overline{MFk.RL} = 1$, then \overline{Nk} does not contain the operand length; instead, it contains a register code for a register holding the operand length.

If $\overline{MFk.ID} = 1$, then the \overline{k} th word following the instruction word does not contain an operand descriptor; instead, it contains an indirect pointer to the operand descriptor.

$C(\overline{Y-charn1})$, $C(\overline{Y-charn2})$, and $C(\overline{Y-charn3})$ may be overlapping strings; no check is made.

Detection of a character outside the range $[0,11]_8$ in a digit position or a character outside the range $[12,17]_8$ in a sign position causes an illegal procedure fault. *

Attempted execution with the \overline{xed} instruction causes an illegal procedure fault.

Attempted repetition with the \overline{rpt} , \overline{rpd} , or \overline{rpl} instructions causes an illegal procedure fault.

MICRO OPERATIONS FOR EDIT INSTRUCTIONS

The Move Alphanumeric Edited (mve) and Move Numeric Edited (mvne) instructions require micro operations to perform the editing functions in an efficient manner. The sequence of micro operation steps to be executed is contained in main memory and is referenced by the second operand descriptor of the mve or mvne instructions. Some of the micro operations require special characters for insertion into the string of characters being edited. These special characters are shown in the "Edit Insertion Table" discussion below.

Micro Operation Sequence

The micro operation string operand descriptor points to a string of 9-bit bytes that specify the micro operations to be performed during an edited move. Each of the 9-bit bytes defines a micro operation and has the following format:

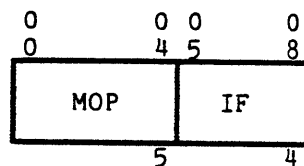

Figure 4-29. Micro Operation (MOP) Character Format

- MOP 5-bit code specifying the micro operator
- IF Information field containing one of the following:
- 1) A sending string character count. A value of 0 is interpreted as 16.
 - 2) The index of an entry in the edit insertion table to be used. Permissible values are 1 through 8.
 - 3) An interpretation of the "blank-when-zero" operation

Edit Insertion Table

While executing an edit instruction, the processor provides a register of eight 9-bit bytes to hold insertion information. This register, called the edit insertion table, is not maintained after execution of an edit instruction. At the start of each edit instruction, the processor initializes the table to the values given in Table 4-8, where each symbol refers to the corresponding standard ASCII character.

Table 4-8. Default Edit Insertion Table Characters

Table Entry Number	Character
1	blank
2	*
3	+
4	-
5	\$
6	,
7	.
8	0 (zero)

One or all of the table entries can be changed by the Load Table Entry (lte) or the Change Table (cht) micro operations to provide different insertion characters.

Edit Flags

The processor provides the following four edit flags for use by the micro operations.

- ES End suppression flag; initially OFF and set ON by a micro operation when zero suppression ends.
- SN Sign flag; initially set OFF if the sending string is alphanumeric or unsigned numeric. If the sending string is signed numeric, the sending string sign character is tested and SN is set OFF if positive, and ON if negative.
- Z Zero flag; initially set ON. It is set OFF whenever a sending string character that is not decimal zero is moved into the receiving string.
- BZ Blank-when-zero flag; initially set OFF and is set ON by either the enf or ses micro operation. If, at the completion of a move, both the Z and BZ are ON, the receiving string is filled with character 1 of the edit insertion table.

Terminating Micro Operations

The micro operation sequence is terminated normally when the receiving string length becomes exhausted. The micro operation sequence is terminated abnormally (with an illegal procedure fault) if a move from an exhausted sending string or the use of an exhausted MOP string is attempted.

MVNE and MVE Differences

The processor executes mvne in a slightly different manner than it executes mve. This is due to the inherent differences in the way numeric and alphanumeric data are handled. The following are brief descriptions of the hardware operations for mvne and mve.

NUMERIC EDIT

1. Load the entire sending string number (maximum length 63 characters) into the decimal unit input buffer as 4-bit digits (high-order truncating 9-bit data). Strip the sign and exponent characters (if any), put them aside into special holding registers and decrease the input buffer count accordingly.
2. Test sign and, if required, set the SN flag.
3. Execute micro operation string, starting with first (4-bit) digit.
4. If an edit insertion table entry or MOP insertion character is to be stored, ANDed, or ORed into a receiving string of 4- or 6-bit characters, high-order truncate the character accordingly.
5. If the receiving string is 9-bit characters, high-order fill the (4-bit) digits from the input buffer with bits 0-4 of character 8 of the edit insertion table. If the receiving string is 6-bit characters, high-order fill the digits with "00"b.

ALPHANUMERIC EDIT

1. Load decimal unit input buffer with sending string characters. Data is read from main memory in unaligned units (not modulo 8 boundary) of Y-block8 words. The number of characters loaded is the minimum of the remaining sending string count, the remaining receiving string count, and 64.
2. Execute micro operation string, starting with the first receiving string character.
3. If an edit insertion table entry or MOP insertion character is to be stored, ANDed, or ORed into a receiving string of 4- or 6-bit characters, high-order truncate the character accordingly.

Micro Operations

A description of the 17 micro operations (MOPs) follows. The mnemonic, name, octal value, and the function performed is given for each MOP in a format similar to that for processor instructions. These micro operations are included in the alphabetic list of instructions in Appendix B, identified by the code MOP.

Checks for termination are made during and after each micro operation. All MOPs that make a zero test of a sending string character test only the four least significant bits of the character.

The following additional abbreviations and symbols are used in the descriptions of the MOPs.

EIT edit insertion table

pin current position in the sending string
 pmop current position in the micro operation string
 pout current position in the receiving string

After each MOP, add one to pmop.

cht	Change Table	21
-----	--------------	----

SUMMARY: For $i = 1, 2, \dots, 8$
 $C(Y\text{-char}_{92})_{pmop+i} \rightarrow C(EIT)_i$
 $pmop = pmop + 8$

FLAGS: None affected

NOTES: C(IF) is not interpreted for this operation.

enf	End Floating Suppression	02
-----	--------------------------	----

SUMMARY: If $C(IF)_0 = 0$, then
 If ES is OFF, then
 If SN is OFF, then $C(EIT)_3 \rightarrow C(Y\text{-char}_{\underline{3}})_{pout}$
 If SN is ON, then $C(EIT)_4 \rightarrow C(Y\text{-char}_{\underline{3}})_{pout}$
 $pout = pout + 1$
 ES set ON
 If ES is ON, then no action
 If $C(IF)_0 = 1$, then
 If ES is OFF, then
 $C(EIT)_5 \rightarrow C(Y\text{-char}_{\underline{3}})_{pout}$
 $pout = pout + 1$
 ES set ON
 If ES is ON, then no action
 If $C(IF)_1 = 1$, then BZ set ON; otherwise no action

MICRO OPERATIONS

FLAGS: (Flags not listed are not affected)
 ES If OFF, then set ON
 BZ If C(IF)₁ = 1, then set ON; otherwise no change

ign	Ignore Source Character	14
-----	-------------------------	----

SUMMARY: pin = pin + C(IF)

FLAGS: None affected

insa	Insert Asterisk on Suppression	11
------	--------------------------------	----

SUMMARY: If ES is OFF, then
 C(EIT)₂ → C(Y-charn₃)_{pout}
 If C(IF) = 0, then pmop = pmop
 If ES is ON, then
 If C(IF) ≠ 0, then
 m = C(IF)
 C(EIT)_m → C(Y-charn₃)_{pout}
 If C(IF) = 0, then
 C(Y-char₉₂)_{pmop+1} → C(Y-charn₃)_{pout}
 pmop = pmop + 1
 pout = pout + 1

FLAGS: None affected

NOTES: If C(IF) > 8 an illegal procedure fault occurs.

insb	Insert Blank on Suppression	10
------	-----------------------------	----

SUMMARY: If ES is OFF, then
 $C(EIT)_1 \rightarrow C(Y\text{-char}_{\underline{n}3})_{pout}$
If $C(IF) = 0$, then $pmop = pmop + 1$
If ES is ON, then
If $C(IF) \neq 0$, then
 $m = C(IF)$
 $C(EIT)_m \rightarrow C(Y\text{-char}_{\underline{n}3})_{pout}$
If $C(IF) = 0$, then
 $C(Y\text{-char}_{92})_{pmop+1} \rightarrow C(Y\text{-char}_{\underline{n}3})_{pout}$
 $pmop = pmop + 1$
 $pout = pout + 1$

FLAGS: None affected

NOTES: If $C(IF) > 8$ an illegal procedure fault occurs.

insm	Insert Table Entry One Multiple	01
------	---------------------------------	----

SUMMARY: For $i = 0, 1, \dots, C(IF) - 1$
 $C(EIT)_i \rightarrow C(Y\text{-char}_{\underline{n}3})_{pout+i}$
 $pout = pout + C(IF)$

FLAGS: None affected

insn	Insert On Negative	12
------	--------------------	----

SUMMARY: If SN is OFF, then
 $C(EIT)_1 \rightarrow C(Y\text{-char}_{\underline{n}3})_{pout}$
If $C(IF) = 0$, then $pmop = pmop + 1$
If SN is ON, then
If $C(IF) \neq 0$, then

MICRO OPERATIONS

$m = C(IF)$

$C(EIT)_m \rightarrow C(Y\text{-char}_{\underline{n}3})_{pout}$

If $C(IF) = 0$, then

$C(Y\text{-char}_{92})_{pmop+1} \rightarrow C(Y\text{-char}_{\underline{n}3})_{pout}$

$pmop = pmop + 1$

$pout = pout + 1$

FLAGS: None affected

NOTES: If $C(IF) > 8$ an illegal procedure fault occurs.

insp	Insert On Positive	13
------	--------------------	----

SUMMARY: If SN is ON, then

$C(EIT)_1 \rightarrow C(Y\text{-char}_{\underline{n}3})_{pout}$

If $C(IF) = 0$, then $pmop = pmop + 1$

If SN is OFF, then

If $C(IF) \neq 0$, then

$m = C(IF)$

$C(EIT)_m \rightarrow C(Y\text{-char}_{\underline{n}3})_{pout}$

If $C(IF) = 0$, then

$C(Y\text{-char}_{92})_{pmop+1} \rightarrow C(Y\text{-char}_{\underline{n}3})_{pout}$

$pmop = pmop + 1$

$pout = pout + 1$

FLAGS: None affected

NOTES: If $C(IF) > 8$ an illegal procedure fault occurs.

lte	Load Table Entry	20
-----	------------------	----

SUMMARY: $m = C(IF)$

$C(Y\text{-char}_{92})_{pmop+1} \rightarrow C(EIT)_m$

$pmop = pmop + 1$

FLAGS: None affected

NOTES: If $C(IF) = 0$ or $C(IF) > 8$ an illegal procedure fault occurs.

mflc	Move with Floating Currency Symbol Insertion	07
------	--	----

SUMMARY: For $i = 0, 1, \dots, C(IF) - 1$

If ES is ON, then $C(Y\text{-char}_{\underline{1}})_{pin+i} \rightarrow C(Y\text{-char}_{\underline{3}})_{pout+i}$

If ES is OFF and $C(Y\text{-char}_{\underline{1}})_{pin+i} = \text{decimal } 0$, then

$C(EIT)_1 \rightarrow C(Y\text{-char}_{\underline{3}})_{pout+i}$

If ES is OFF and $C(Y\text{-char}_{\underline{1}})_{pin+i} \neq \text{decimal } 0$, then

$C(EIT)_5 \rightarrow C(Y\text{-char}_{\underline{3}})_{pout+i}$

$C(Y\text{-char}_{\underline{1}})_{pin+i} \rightarrow C(Y\text{-char}_{\underline{3}})_{pout+i+1}$

$pout = pout + 1$

ES set ON

$pin = pin + C(IF)$

$pout = pout + C(IF)$

FLAGS: (Flags not listed are not affected)

ES If OFF and any of $C(Y\text{-char}_{\underline{1}})_{pin+i} \neq \text{decimal } 0$, then ON; otherwise unchanged

Z See the "Edit Flags" section.

NOTES: The number of characters moved to the receiving string is data dependent. If the entire $C(Y\text{-char}_{\underline{1}})$ are decimal 0s, $C(IF)$ characters are moved to $C(Y\text{-char}_{\underline{3}})$. However, if the sending string contains a non-zero character, then $C(IF)+1$ characters are moved to $C(Y\text{-char}_{\underline{3}})$; the insertion character plus $C(Y\text{-char}_{\underline{1}})$. A possible illegal procedure fault due to this condition may be avoided by assuring that the Z and BZ flags are ON.

mfls	Move with Floating Sign Insertion	06
------	-----------------------------------	----

SUMMARY: For $i = 0, 1, \dots, C(IF) - 1$

If ES is ON, then $C(Y\text{-char}_{\underline{1}})_{pin+i} \rightarrow C(Y\text{-char}_{\underline{3}})_{pout+i}$

If ES is OFF and $C(Y\text{-char}_{\underline{1}})_{pin+i} = \text{decimal } 0$, then

$C(EIT)_1 \rightarrow C(Y\text{-char}_{\underline{3}})_{pout+i}$

MICRO OPERATIONS

If ES is OFF and $C(Y\text{-charn}_1)_{pin+i} \neq \text{decimal } 0$, then
 If SN is OFF, then $C(EIT)_3 \rightarrow C(Y\text{-charn}_3)_{pout+i}$
 If SN is ON, then $C(EIT)_4 \rightarrow C(Y\text{-charn}_3)_{pout+i}$
 $C(Y\text{-charn}_1)_{pin+i} \rightarrow C(Y\text{-charn}_3)_{pout+i+1}$
 $pout = pout + 1$
 ES set On

$pin = pin + C(IF)$
 $pout = pout + C(IF)$

FLAGS: (Flags not listed are not affected)

ES If OFF and any of $C(Y\text{-charn}_1)_{pin+i} \neq \text{decimal } 0$, then ON; otherwise unchanged

Z See the "Edit Flags" section

NOTES: The number of characters moved to the receiving string is data dependent. If the entire $C(Y\text{-charn}_1)$ are decimal 0s, $C(IF)$ characters are moved to $C(Y\text{-charn}_3)$. However, if the sending string contains a non-zero character, then $C(IF)+1$ characters are moved to $C(Y\text{-charn}_3)$; the insertion character plus $C(Y\text{-charn}_1)$. A possible illegal procedure fault due to this condition may be avoided by assuring that the Z and BZ flags are ON.

mors	Move and OR Sign	17
------	------------------	----

SUMMARY: For $i = 0, 1, \dots, C(IF) - 1$

If SN is OFF, then
 $C(Y\text{-charn}_1)_{pin+i} \mid C(EIT)_3 \rightarrow C(Y\text{-charn}_3)_{pout+i}$
 If SN is ON, then
 $C(Y\text{-charn}_1)_{pin+i} \mid C(EIT)_4 \rightarrow C(Y\text{-charn}_3)_{pout+i}$

$pin = pin + C(IF)$
 $pout = pout + C(IF)$

FLAGS: (Flags not listed are not affected)

Z See the "Edit Flags" section

mss	Move and Set Sign	16
-----	-------------------	----

SUMMARY: For mvne
 For $i = 0, 1, \dots, C(IF) - 1$
 $C(Y\text{-charn}_1)_{pin+i} \rightarrow C(Y\text{-charn}_3)_{pout+i}$
 $pin = pin + C(IF)$
 $pout = pout + C(IF)$
 For mve
 $C(Z) = 0$
 For $i = 0, 1, \dots, C(IF) - 1$
 $C(Y\text{-charn}_1)_{pin+i} \rightarrow C(Y\text{-charn}_3)_{pout+i}$
 If $C(Z) = 0$, then
 $C(Z) = C(Y\text{-charn}_1)_{pin+i} \& C(EIT)_3$
 If $C(Z) = 0$, then
 $C(Z) = C(Y\text{-charn}_1)_{pin+i} \& C(EIT)_4$
 If $C(Z) \neq 0$, then SN set ON
 $pin = pin + C(IF)$
 $pout = pout + C(IF)$

FLAGS: (Flags not listed are not affected)

 SN If $C(EIT)_4$ found in $C(Y\text{-charn}_1)$, then ON; otherwise no change

 Z See the "Edit Flags" section

mvs	Move Source Characters	15
-----	------------------------	----

SUMMARY: For $i = 0, 1, \dots, C(IF) - 1$
 $C(Y\text{-charn}_1)_{pin+i} \rightarrow C(Y\text{-charn}_3)_{pout+i}$
 $pin = pin + C(IF)$
 $pout = pout + C(IF)$

FLAGS: (Flags not listed are not affected)

 Z See the "Edit Flags" section

MICRO OPERATIONS

mvza	Move with Zero Suppression and Asterisk Replacement	05
------	---	----

SUMMARY: For $i = 0, 1, \dots, C(IF) - 1$

If ES is ON, then $C(Y\text{-charn}_1)_{pin+i} \rightarrow C(Y\text{-charn}_3)_{pout+i}$

If ES is OFF and $C(Y\text{-charn}_1)_{pin+i} = \text{decimal } 0$, then
 $C(EIT)_2 \rightarrow C(Y\text{-charn}_3)_{pout+i}$

If ES is OFF and $C(Y\text{-charn}_1)_{pin+i} \neq \text{decimal } 0$, then
 $C(Y\text{-charn}_1)_{pin+i} \rightarrow C(Y\text{-charn}_3)_{pout+i}$

ES set On

pin = pin + C(IF)

pout = pout + C(IF)

FLAGS: (Flags not listed are not affected)

ES If OFF and any of $C(Y\text{-charn}_1)_{pin+i} \neq \text{decimal } 0$, then ON; otherwise unchanged

Z See the "Edit Flags" section

mvzb	Move with Zero Suppression and Blank Replacement	04
------	--	----

SUMMARY: For $i = 0, 1, \dots, C(IF) - 1$

If ES is ON, then $C(Y\text{-charn}_1)_{pin+i} \rightarrow C(Y\text{-charn}_3)_{pout+i}$

If ES is OFF and $C(Y\text{-charn}_1)_{pin+i} = \text{decimal } 0$, then
 $C(EIT)_1 \rightarrow C(Y\text{-charn}_3)_{pout+i}$

If ES is OFF and $C(Y\text{-charn}_1)_{pin+i} \neq \text{decimal } 0$, then
 $C(Y\text{-charn}_1)_{pin+i} \rightarrow C(Y\text{-charn}_3)_{pout+i}$

ES set ON

pin = pin + C(IF)

pout = pout + C(IF)

FLAGS: (Flags not listed are not affected)

ES If OFF and any of $C(Y\text{-charn}_1)_{pin+i} \neq \text{decimal } 0$, then ON; otherwise unchanged

Z See the "Edit Flags" section

ses	Set End Suppression	03
-----	---------------------	----

SUMMARY: If C(IF)₀ = 0, then ES set OFF
 If C(IF)₀ = 1, then ES set ON
 If C(IF)₁ = 1, then BZ set ON; otherwise no action

FLAGS: (Flags not listed are not affected)

ES Set by this micro operation
 BZ If C(IF)₁ = 1, then ON; otherwise no change

Micro Operation Code Assignment Map

Operation code assignments for the micro operations are shown in Table 4-9. A dash (----) indicates an unassigned code. All unassigned codes cause an illegal procedure fault.

Table 4-9. Micro Operation Code Assignment Map

	0	1	2	3	4	5	6	7
00	----	insm	enf	ses	mvzb	mvza	mfls	mflc
10	insb	insa	insn	insp	ign	mvc	msep	mors
20	lte	cht	----	----	----	----	----	----
30	----	----	----	----	----	----	----	----

SECTION 5

ADDRESSING -- SEGMENTATION AND PAGING

ADDRESSING MODES

The Multics processor is able to access the main memory in either absolute mode or append mode. The processor prepares an 18-bit computed address (TPR.CA) for each main memory reference for instructions or operands using the address preparation algorithms described in Section 6. This computed address is a scalar index into a virtual memory with an extent of 262,144 words.

Absolute Mode

In absolute mode, the appending unit is bypassed for instruction fetches and most operand fetches and the final 18-bit computed address (TPR.CA) from address preparation becomes the absolute main memory address.

Thus, all instructions to be executed in absolute mode must reside in the low-order 262,144 words of main memory, that is, main memory addresses 0 through 262,143. Operands normally also reside in the low-order 262,144 words of main memory but, by specifying in an instruction word that the appending unit be used for the main memory access, operands may reside anywhere in main memory. An appended operand fetch may be specified by:

1. Specifying register then indirect (ri) address modification in the instruction word and indirect to segment (its) or indirect to pointer (itp) address modification in the indirect word.
2. Specifying pointer register modification in the instruction word (bit 29 = 1) and giving a pointer register number in the instruction address C(y)_{0,2}.
3. Specifying pointer register modification (MF_k.AR = 1) in the modification field for an EIS operand descriptor.

The use of any of the above constructs in absolute mode places the processor in append mode for one or more address preparation cycles. All necessary registers must be properly loaded, all tables of segment descriptor words (SDWs) and page table words (PTWs) expected by the appending unit must exist and be properly described, and all fault conditions must be considered (see append mode below).

If a transfer of control is made with any of the above constructs, the processor remains in append mode after the transfer and subsequent instruction fetches are made in append mode.

Although no segment is defined for absolute mode, it may be helpful to visualize a virtual, unpagged segment overlaying the first 262,144 words of main memory.

Append Mode

In append mode, the appending unit is employed for all main memory references. The appending unit is described later in this section.

SEGMENTATION

In Multics, a segment is defined as an array of arbitrary (but limited) size of machine words containing arbitrary data. A segment is identified within the processor by a segment number (segno) unique to the segment.

To simplify this discussion, the operation of the hardware ring mechanism is not described although it is an integral part of address preparation. See Section 8 for a discussion of the ring mechanism hardware.

A virtual memory address in the processor consists of a pair of integers, (segno, offset). The range of segno is $[0, 2^{15}-1]$ and the range of offset is $[0, 2^{18}-1]$. The description of the segment whose segno value is n is kept in the n^{th} word-pair in a table known as the descriptor segment. The location of the descriptor segment is held by the processor in the descriptor segment base register (DSBR) (see Section 3). Each word-pair of a descriptor segment is known as a segment descriptor word (SDW) and is 72 bits long (see Figure 5-5).

A bit in the SDW for a segment (SDW.U) specifies whether the segment is paged or unpagged. The following is a simplified description of the appending process for unpagged segments (also using an unpagged descriptor segment) (refer to Figures 2-14 and 5-5).

1. If $2 * \text{segno} \geq 16 * (\text{DSBR.BND} + 1)$, then generate an access violation, out of segment bounds, fault.
2. Fetch the target segment SDW from $\text{DSBR.ADDR} + 2 * \text{segno}$.
3. If $\text{SDW.F} = 0$, then generate directed fault n where n is given in SDW.FC . The value of n used here is the value assigned to define a missing segment fault or, simply, a segment fault.
4. If $\text{offset} \geq 16 * (\text{SDW.BOUND} + 1)$, then generate an access violation, out of segment bounds, fault.
5. If the access bits (SDW.R , SDW.E , etc.) of the segment are incompatible with the reference, generate the appropriate access violation fault.
6. Generate 24-bit absolute main memory address $\text{SDW.ADDR} + \text{offset}$.

Figure 5-1 depicts the relationships just described.

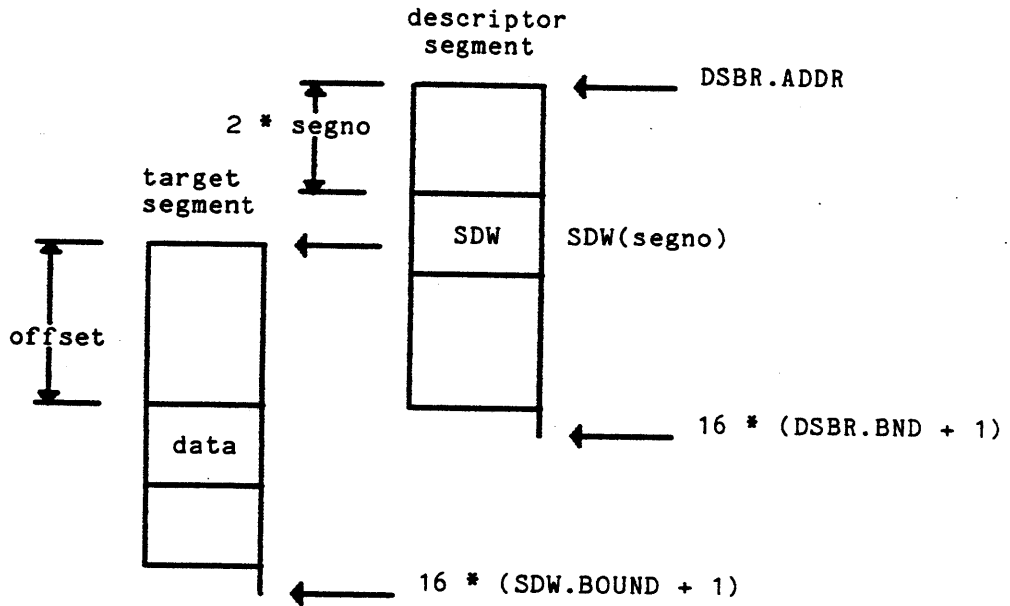

Figure 5-1. Main Memory Address Generation for Unpagged Segments

PAGING

In Multics, a page is defined as a block of virtual memory with a size of 2^{10} machine words. The processor is designed in such a way that the page size is adjustable over the range $[2^0, 2^{12}]$ but no basis has been found to justify an assertion that any page size is more efficient than 2^{10} or 1024 words.

The processor divides a k-bit offset or segno value into two parts; the high-order (k-n) bits forming a page number, x, and the low-order n bits forming a word number, y. This may be stated as:

$$y = (\text{value}) \text{ modulo } (\text{page size})$$

$$x = (\text{value} - y) / (\text{page size})$$

The symbols x and y are used in this context throughout this section. An example of page number formation is shown in Figure 5-2.

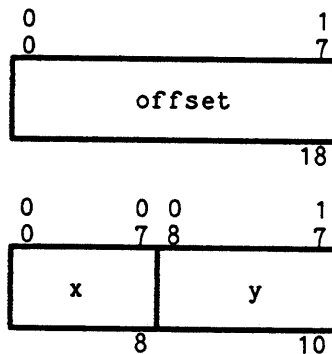

Figure 5-2. Page Number Formation

A bit in the SDW for a segment (SDW.U) specifies whether the segment is paged or unpaged. A paged segment may be defined as an array of arbitrary (but limited) size of pages and a page may be defined as an array of 1024 machine words. Thus, x is a scalar index into the array of pages, y is a scalar index into the page, and a reference to a word of a paged segment may be treated as a reference to word y of page x of the segment.

Multics subdivides the virtual memory into page size blocks of 1024 words each. Such a subdivision of space allows a segment page to be handled as a physical block independently from the other pages of the segment and from other segments. In main memory, the blocks are known as frames; on secondary storage, they are known as records. When a reference to a word in a paged segment is required (and the page containing the word is not already in main memory), a main memory frame is allocated and the page is read in from secondary storage. Unneeded pages need not occupy space in main memory.

The location and status of page x of a paged segment is kept in the x^{th} word of a table known as the page table for the segment. The words in this table are known as page table words (PTWs) (see Figure 5-6).

Any segment may be paged as appropriate and convenient. The address field of the segment descriptor word (SDW.ADDR) for a paged segment contains the 24-bit absolute main memory address of the page table for the segment instead of the address of the origin of the segment. If the descriptor segment is paged, the address field of the descriptor segment base register (DSBR.ADDR) contains the 24-bit absolute main memory address of the page table for the descriptor segment.

The full algorithm used by the processor to access word offset of paged segment segno (including descriptor segment paging) is as follows. (Refer to Figures 2-14, 5-5, and 5-6.)

1. If $2 * \text{segno} \geq 16 * (\text{DSBR.BND} + 1)$, then generate an access violation, out of segment bounds, fault.
2. Form the quantities:
$$y1 = (2 * \text{segno}) \text{ modulo } 1024$$
$$x1 = (2 * \text{segno} - y1) / 1024$$
3. Fetch the descriptor segment PTW($x1$) from DSBR.ADDR + $x1$.
4. If PTW($x1$).F = 0, then generate directed fault n where n is given in PTW($x1$).FC. The value of n used here is the value assigned to define a missing page fault or, simply, a page fault.
5. Fetch the target segment SDW, SDW(segno), from the descriptor segment page at PTW($x1$).ADDR + $y1$.
6. If SDW(segno).F = 0, then generate directed fault n where n is given in SDW(segno).FC. This is a segment fault as discussed earlier in this section.
7. If $\text{offset} \geq 16 * (\text{SDW}(\text{segno}).\text{BOUND} + 1)$, then generate an access violation, out of segment bounds, fault.
8. If the access bits (SDW(segno).R, SDW(segno).E, etc.) of the segment are incompatible with the reference, generate the appropriate access violation fault.
9. Form the quantities:
$$y2 = \text{offset modulo } 1024$$
$$x2 = (\text{offset} - y2) / 1024$$

10. Fetch the target segment PTW(x2) from SDW(segno).ADDR + x2.
11. If PTW(x2).F = 0, then generate directed fault n where n is given in PTW(x2).FC. This is a page fault as in Step 4 above.
12. Generate the 24-bit absolute main memory address PTW(x2).ADDR + y2.

Figure 5-3 depicts the relationships described above.

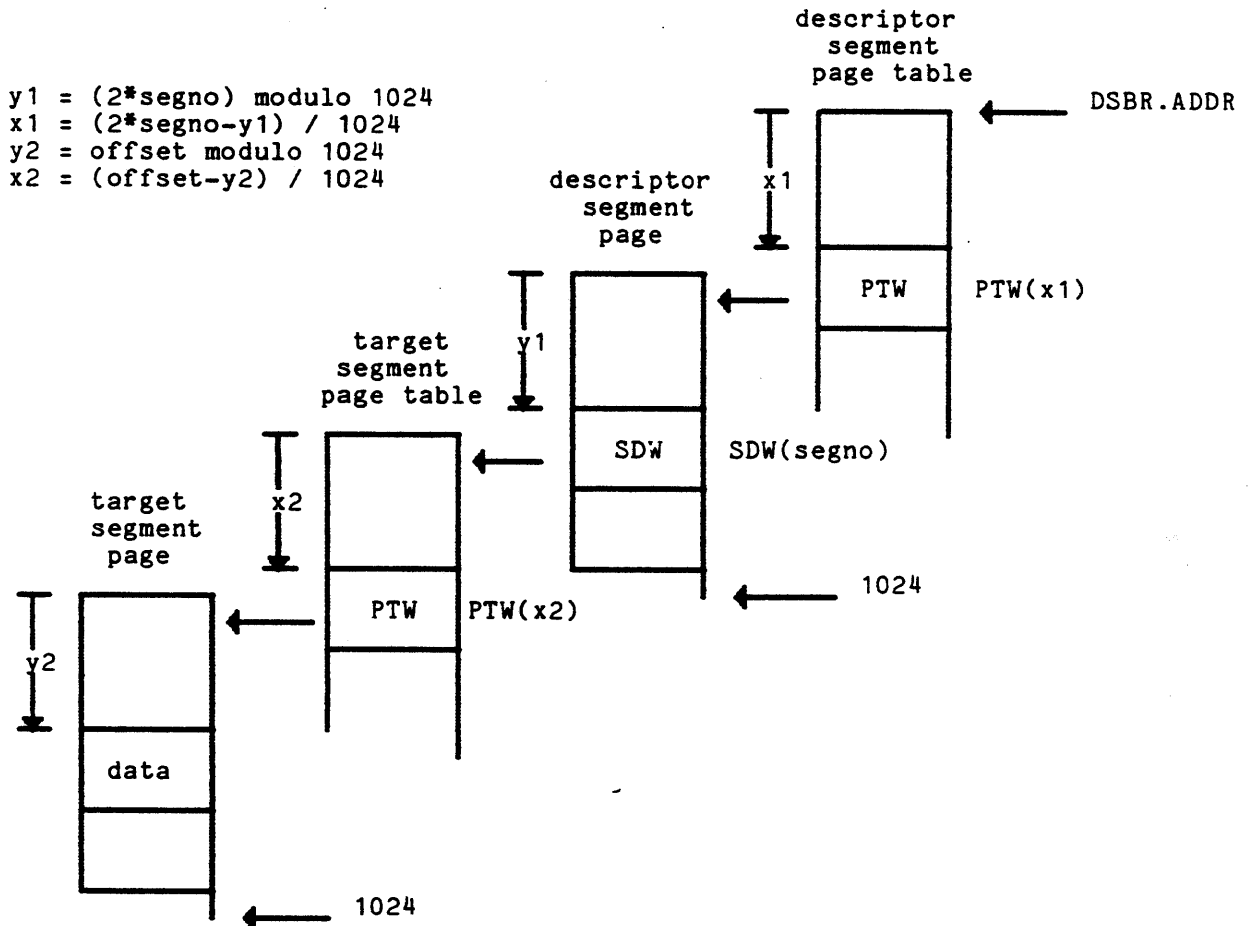

Figure 5-3. Main Memory Address Generation for Paged Segments

CHANGING ADDRESSING MODES

The processor is placed in absolute mode by the initialize, initialize and clear, or system initialize functions. The first response to faults and interrupts is in absolute mode and the mode thereafter is determined by the instruction sequence entered through the fault or interrupt trap pair. The processor remains in absolute mode until a transfer of control via the appending unit takes place. Note that a Return (ret) or Restore Control Unit (rcu) instruction that sets the absolute indicator OFF (see Section 3 for a discussion of the indicators) or a Return Control Double (rtcd) instruction also places the processor in append mode.

When it responds to a fault or interrupt, the processor enters absolute mode temporarily for the fetch and execution of the trap pair. If an unappended

transfer is executed while in the trap pair, the processor remains in absolute mode, otherwise it returns to append mode.

ADDRESS APPENDING

At the completion of the formation of the virtual memory address (see Section 6) an effective segment number (segno) is in the segment number register of the temporary pointer register (TPR.SNR) and a computed address (offset) is in the computed address register of the temporary pointer register (TPR.CA.) (See Section 3 for a discussion of the temporary pointer register.)

Address Appending Sequences

Once segno and offset are formed in TPR.SNR and TPR.CA, respectively, the process of generating the 24-bit absolute main memory address can involve a number of different and distinct appending unit cycles.

The operation of the appending unit is shown in the flowchart in Figure 5-4. This flowchart assumes that directed faults, store faults, and parity faults do not occur.

A segment boundary check is made in every cycle except PSDW. If a boundary violation is detected, an access violation, out of segment bounds, fault is generated and the execution of the instruction interrupted. The occurrence of any fault interrupts the sequence at the point of occurrence. The operating system software should store the control unit data for possible later continuation and attempt to resolve the fault condition.

The value of the associative memories may be seen in the flowchart by observing the number of appending unit cycles bypassed if an SDW or PTW is found in the associative memories.

There are nine different appending unit cycles that involve accesses to main memory. Two of these (FANP, FAP) generate the 24-bit absolute main memory address and initiate a main memory access for the operand, indirect word, or instruction pair; five (NSDW, PSDW, PTW, PTW, and DSPTW) generate a main memory access to fetch an SDW or PTW; and two (MDSPTW and MPTW) generate a main memory access to update page status bits (PTW.U and PTW.M) in a PTW. The cycles are defined in Table 5-1.

Table 5-1. Appending Unit Cycle Definitions

Cycle name	Function
FANP	<p>Final address nonpaged</p> <p>Generates the 24-bit absolute main memory address and initiates a main memory access to an unpaged segment for operands, indirect words, or instructions.</p>
FAP	<p>Final address paged</p> <p>Generates the 24-bit absolute main memory address and initiates a main memory access to a paged segment for operands, indirect words, or instructions.</p>
NSDW	<p>Nonpaged SDW Fetch</p> <p>Fetches an SDW from an unpaged descriptor segment.</p>
PSDW	<p>Paged SDW Fetch</p> <p>Fetches an SDW from a paged descriptor segment.</p>
PTW	<p>PTW fetch</p> <p>Fetches a PTW from a page table other than a descriptor segment page table and sets the page accessed bit (PTW.U).</p>
PTW2	<p>Prepage PTW fetch</p> <p>Fetches the next PTW from a page table other than a descriptor segment page table during hardware prepaging for certain uninterruptable EIS instructions. This cycle does <u>not</u> load the next PTW into the appending unit. It merely assures that the PTW is not faulted (PTW.F = 1) and that the target page will be in main memory when and if needed by the instruction.</p>
DSPTW	<p>Descriptor segment PTW fetch</p> <p>Fetches a PTW from a descriptor segment page table.</p>
MDSPTW	<p>Modify DSPTW</p> <p>Sets the page accessed bit (PTW.U) in the PTW for a page in a descriptor segment page table. This cycle always immediately follows a DSPTW cycle.</p>
MPTW	<p>Modify PTW</p> <p>Sets the page modified bit (PTW.M) in the PTW for a page in other than a descriptor segment page table.</p>

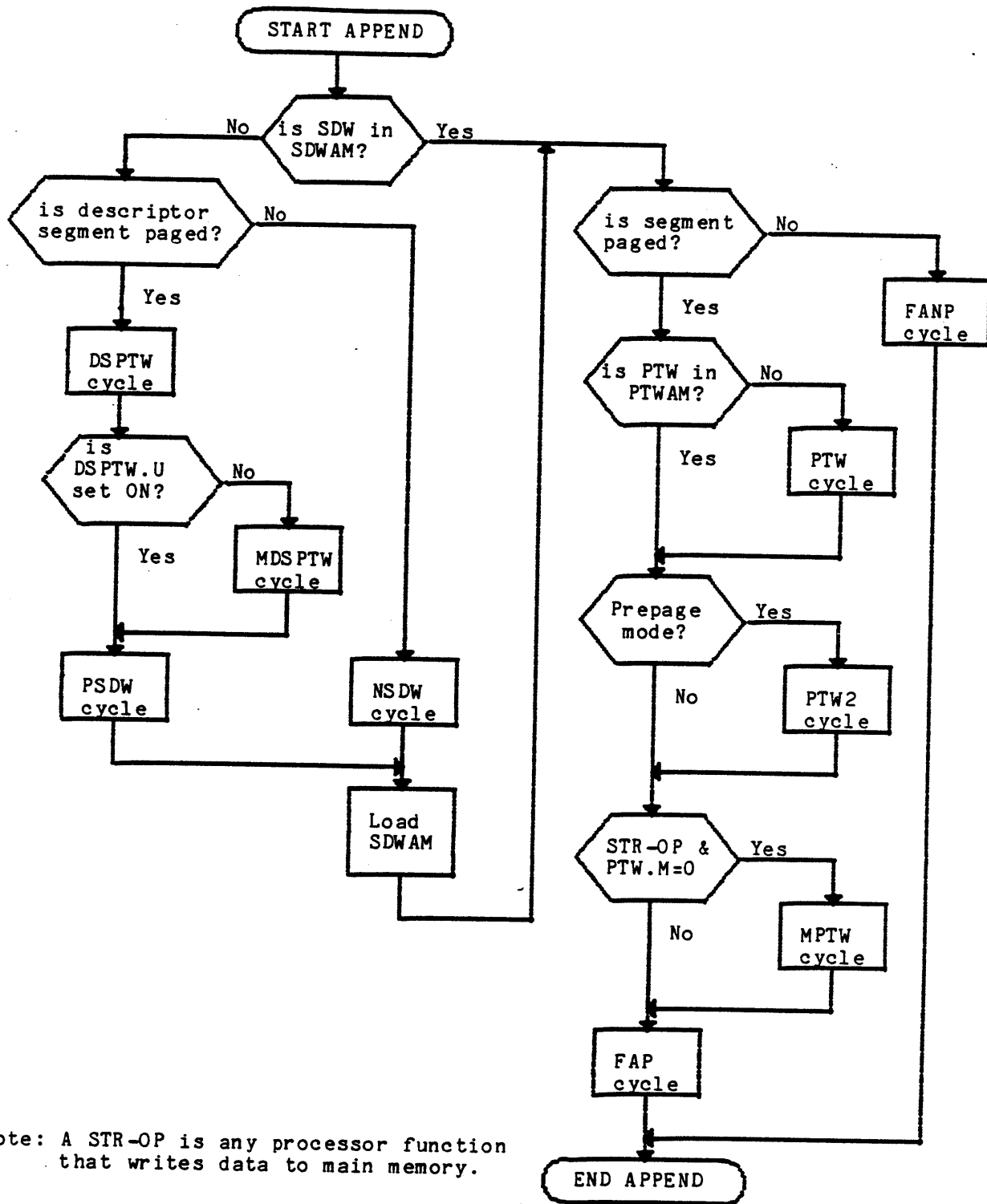

Note: A STR-OP is any processor function that writes data to main memory.

Figure 5-4. Appending Unit Operation Flowchart

APPENDING UNIT DATA WORD FORMATS

Segment Descriptor Word (SDW) Format

The segment descriptor word (SDW) pair contains information that controls the access to a segment. The SDW for segment n is located at offset $2n$ in the descriptor segment whose description is currently loaded into the descriptor segment base register (DSBR).

Even word

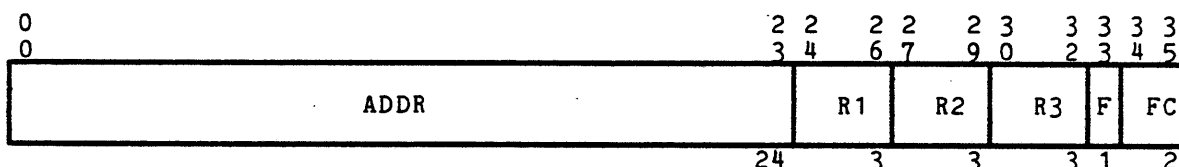

Odd word

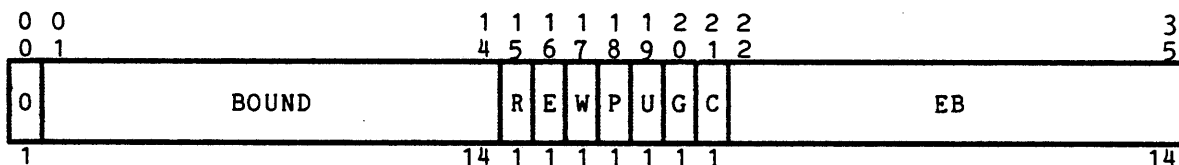

Figure 5-5. Segment Descriptor Word (SDW) Format

<u>Field Name</u>	<u>Description</u>
ADDR	24-bit absolute main memory address of unpagged segment (U=1) or segment page table (U=0)
R1,R2,R3	Ring brackets (see Section 8)
F	Directed fault flag 1 = the unpagged segment or segment page table is in main memory 0 = execute the directed fault specified in FC
FC	The number of the directed fault (df0-df3) to be executed if F=0
BOUND	14 high-order bits of the largest 18-bit modulo 16 offset that may be accessed without causing a descriptor violation, out of segment bounds, fault

<u>Field Name</u>	<u>Description</u>
R	Read permission bit
E	Execute permission bit (xec and xed instructions excluded)
W	Write permission bit
P	Privileged mode bit 0 = privileged instructions cannot be executed 1 = privileged instructions may be executed if in ring 0
U	Paged/unpaged control bit 0 = segment is paged; ADDR is the 24-bit main memory address of the page table 1 = segment is unpaged; ADDR is the 24-bit main memory address of the origin of the segment
G	Gate indicator bit 0 = any call into the segment must be to an offset less than the value of EB 1 = any legal segment offset may be called
C	Cache control bit 0 = words (operands or instructions) from this segment may not be placed in the cache memory 1 = words from this segment may be placed in the cache memory
EB	Entry bound Any call into this segment must be to an offset less than EB if G=0

Page Table Word (ptw) Format

The page table word (PTW) contains main memory address and status information for a page of a paged segment.

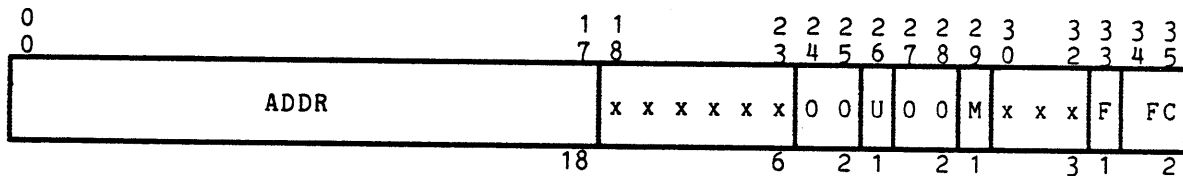

Figure 5-6. Page Table Word (PTW) Format

Bits pictured as "x" are ignored by the hardware and may be used by the operating system software.

<u>Field Name</u>	<u>Description</u>
ADDR	18-bit modulo 64 absolute main memory address of page
	The hardware ignores low order bits of the main memory page address according to page size based on the following:

<u>Page Size in words</u>	<u>ADDR Bits ignored</u>
64	none
128	17
256	16-17
512	15-17
1024	14-17
2048	13-17
4096	12-17

U	1 = page has been used (referenced)
M	1 = page has been modified
F	Directed fault flag
	1 = page is in main memory
	0 = page not in main memory; execute directed fault FC
FC	directed fault number for page fault.

SECTION 6

VIRTUAL ADDRESS FORMATION

DEFINITION OF VIRTUAL ADDRESS

The virtual address in the Multics processor is the user's specification of the location of a data item in the Multics virtual memory. Each reference to the virtual memory for operands, indirect words, indirect pointers, operand descriptors, or instructions must provide a virtual address. The hardware and the operating system translate the virtual address into the true location of the data item and assure that the data item is in main memory for the reference.

The virtual address consists of two parts, an effective segment number and an offset or computed address. The value of each part is the result of the evaluation of a hardware algorithm (expression) of one or more terms. The selection of the algorithm is made by the use of control bits in the instruction word; for example, bit 29 for modification by pointer register and bits 30-35 (the TAG field) for modification by index register or indirect word. For certain modifications by indirect word, the TAG field of the indirect word is also treated as an address modifier, thus establishing a continuing "indirect chain". Bit 29 of an indirect word has no meaning in the context of virtual address formation.

The results of evaluation of the virtual address formation algorithms are stored in temporary registers used as working registers by the processor. The effective segment number is stored in the temporary segment register, TPR.TSR. The offset is stored in the computed address register, TPR.CA. When each virtual address computation has been completed, C(TPR.TSR) and C(TPR.CA) are presented to the appending unit for translation to a 24-bit absolute main memory address (see Section 5).

TYPES OF VIRTUAL ADDRESS FORMATION

There are two types of virtual address formation. The first type does not make explicit use of segment numbers. The algorithms produce values for the computed address, C(TPR.CA), only. The effective segment number in C(TPR.TSR) does not change from the value used to fetch the current instruction. In this case, all references are said to be "local" to the procedure segment pointed to by the procedure pointer register (PPR).

The second type makes use of a segment number in an indirect word-pair in main memory or in a pointer register (PRn). The algorithms produce values for both the effective segment number, C(TPR.TSR), and the computed address, C(TPR.CA). The effective segment number in C(TPR.TSR) may change and, if it changes, references are said to be "external" to the procedure segment.

Both types of virtual address formation for the operand of a basic or EIS single-word instruction begins with a preliminary step of loading TPR.CA with

the ADDRESS field of the instruction word. This preliminary step takes place during instruction decode.

The two types of virtual address formation can be intermixed. In cases where virtual address calculations are chained together through pointer registers or indirect words, each virtual address is translated to a 24-bit absolute main memory address to fetch the next item in the chain.

This description of virtual address formation is divided into two parts corresponding to the two types. The first part describes the type that involves only the computed address, C(TPR.CA). The effective segment number is constant. In append mode its value is equal to C(PPR.PSR) (a local reference) and in absolute mode its value is undefined.

The second part describes the type that involves both the effective segment number, C(TPR.TSR), and the computed address, C(TPR.CA).

SYMBOLOLOGY (ALM)

In many instances in the discussions that follow, references to the features of the ALM assembly program are unavoidable. Such references are explained briefly here. The reader is advised to consult the appropriate software documentation for further details and for possible changes in the various features.

Symbolic Fields

A symbolic field is an expression consisting of variables, constants, literals, and operators that is evaluated by ALM to produce a value for the corresponding field of a machine word. The values of the variables and constants are either known or assignable and the operators are defined for the mode of the evaluation (algebraic, logical, etc.). The necessary fields for a machine instruction or ALM pseudo-instruction are given as a comma-separated string of expressions.

Alm Pseudo-Instructions

The following ALM pseudo-instructions are used in this sections:

aci string

This pseudo-instruction generates a sequence of 9-bit byte fields each of which contains the ASCII octal value for the corresponding graphic character in string. The last machine word generated is low-order filled with binary 0s to the next word boundary.

arg address,tag

This pseudo-instruction generates a machine word with the same format as the basic and EIS single-word instructions but having binary 0s in the operation code field.

bci string

This pseudo-instruction generates a sequence of 6-bit character fields each of which contains the binary coded decimal (BCD) octal value for the corresponding graphic character in string. The last machine word generated is low-order filled with binary 0s to the next word boundary.

vfd field1,field2, ... ,fieldn

This pseudo-instruction generates a machine word (or word-pair) containing an arbitrary number of fields of arbitrary length up to a total bit count of 72. The data generated is left-justified in the machine word (or word-pair) and zero filled to the next word boundary as necessary.

Each fieldi is given as:

md/expr

where: m is the data conversion mode and may be:

 null for arithmetic operators and decimal literals,
 o for Boolean operators and octal literals,
 h for 6-bit character binary coded decimal (BCD)
 character strings, or
 a for 9-bit byte ASCII character strings.

d is a literal giving the field width in bits and may have any value from 1 to 72.

expr is the expression to be evaluated or converted. Conversion is done with full 36-bit precision and the field value is the conversion result modulo the field width.

COMPUTED ADDRESS FORMATION

The address formation algorithms described here produce values only for the computed address. The effective segment number is constant and equal to C(PPR.PSR) if the processor is in append mode or is undefined if the processor is in absolute mode.

The Address Modifier (TAG) Field

Bits 30-35 of an instruction word or indirect word constitute the address modifier or TAG field. The format of the TAG field is:

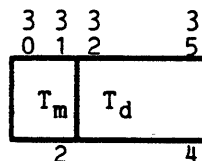

Figure 6-1. Address Modifier (TAG) Field Format

<u>Field Name</u>	<u>Function</u>
T _m	modifier field, specifies one of four general types of computed address modification
T _d	designator field, selects among several variations available for the general type given with T _m

General Types of Computed Address Modification

There are four general types of computed address modification: register, register then indirect, indirect then register, and indirect then tally. The general types are described in Table 6-1. The value loaded into TPR.CA is symbolized by "y" in the descriptions following.

Table 6-1. General Computed Address Modification Types

T_m value	Type	Description								
0	Register (r)	The contents of the register specified in $C(T_d)$ are added to the current computed address, $C(TPR.CA)$, to form the modified computed address. Addition is twos complement, modulo 2^{18} , and overflow does not occur.								
1	Register then indirect (ri)	The contents of the register specified in $C(T_d)$ are added to the current computed address, $C(TPR.CA)$, to form the modified computed address as for register modification. The modified $C(TPR.CA)$ is then used to fetch an indirect word. The TAG field of the indirect word specifies the next step in computed address formation. The use of du or dl as the designator in this modification type will cause an illegal procedure, illegal modifier, fault.								
2	indirect then tally (it)	The indirect word at $C(TPR.CA)$ is fetched and the modification performed according to the variation specified in $C(T_d)$ of the instruction word and the contents of the indirect word. This modification type allows automatic incrementing and decrementing of addresses and tally counting.								
3	indirect then register (ir)	<p>The register designator, $C(T_d)$, is safe-stored in a special holding register, CT-HOLD. The word at $C(TPR.CA)$ is fetched and interpreted as an indirect word. The TAG field of the indirect word specifies the next step in computed address formation as follows:</p> <p>Indirect</p> <table border="0"> <thead> <tr> <th><u>TAG</u></th> <th><u>Next step</u></th> </tr> </thead> <tbody> <tr> <td>r or it</td> <td>Perform-register modification using T_d from CT-HOLD. (1)</td> </tr> <tr> <td>ri</td> <td>Perform the register then indirect modification immediately and fetch the next indirect word from the result of that modification.</td> </tr> <tr> <td>ir</td> <td>Replace the safe-stored T_d value in CT-HOLD with the T_d value from the indirect word TAG field and use the ADDRESS field of the indirect word as a computed address value to fetch the next indirect word.</td> </tr> </tbody> </table>	<u>TAG</u>	<u>Next step</u>	r or it	Perform-register modification using T_d from CT-HOLD. (1)	ri	Perform the register then indirect modification immediately and fetch the next indirect word from the result of that modification.	ir	Replace the safe-stored T_d value in CT-HOLD with the T_d value from the indirect word TAG field and use the ADDRESS field of the indirect word as a computed address value to fetch the next indirect word.
<u>TAG</u>	<u>Next step</u>									
r or it	Perform-register modification using T_d from CT-HOLD. (1)									
ri	Perform the register then indirect modification immediately and fetch the next indirect word from the result of that modification.									
ir	Replace the safe-stored T_d value in CT-HOLD with the T_d value from the indirect word TAG field and use the ADDRESS field of the indirect word as a computed address value to fetch the next indirect word.									

(1) In this instance, the indirect then tally variations fault tag 1, fault tag 2, and fault tag 3 are treated differently. The fault tag 1 variation results in the action described here but fault tag 2 and fault tag 3 result in the generation of a fault. See the discussion of indirect then tally modification later in this section.

Computed Address Formation Flowcharts

The flowcharts depicting the computed address formation process are scattered throughout this section and are linked together by figure references. The flowcharts start with Figure 6-2.

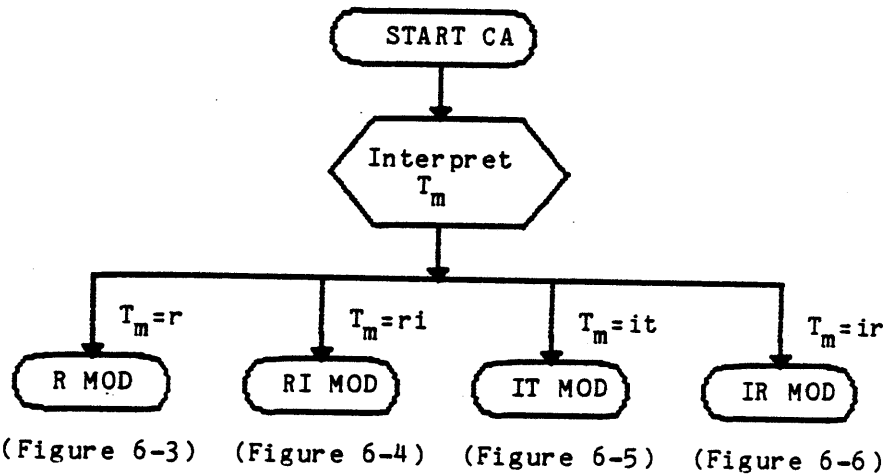

Figure 6-2. Common Computed Address Formation Flowchart

Register (r) Modification

In register modification ($T_m = 0$) the value of T_d designates a register whose contents are to be added to $C(TPR.CA)$ to form a modified $C(TPR.CA)$. This modified $C(TPR.CA)$ becomes the computed address of the operand. See Figure 6-3, Table 6-2, and the examples following.

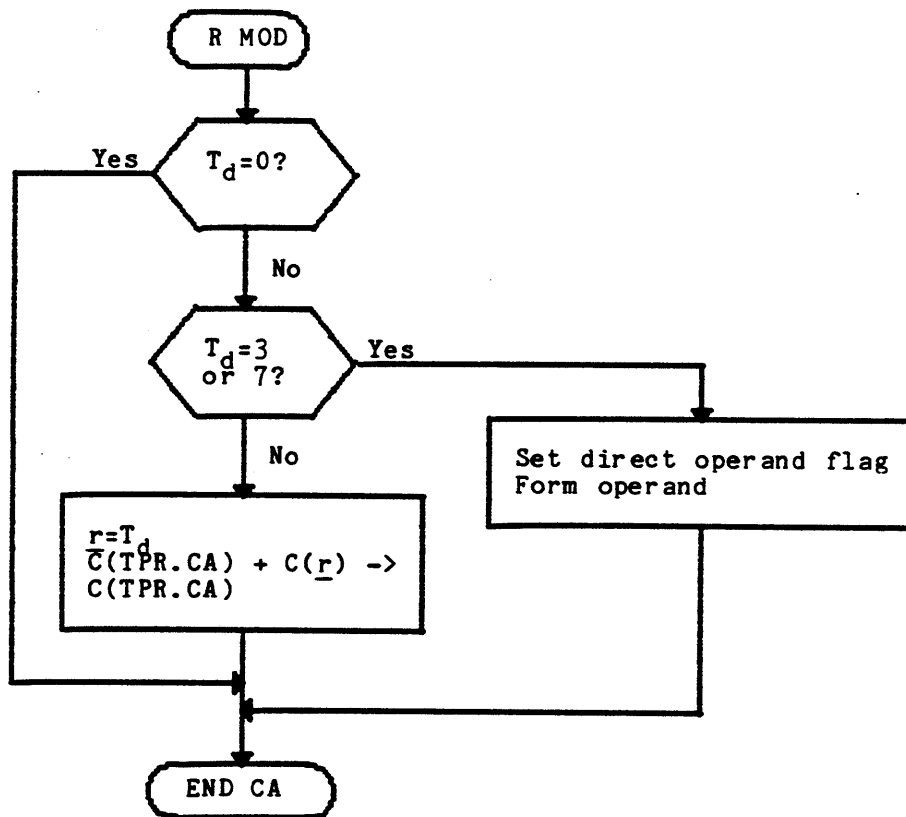

Figure 6-3. Register Modification Flowchart

Table 6-2. Register Modification Decode

T^d value	Register	Coding Symbol	Computed Address
0	none	n, null	y
1	A _{0,17}	au	$y + C(A)_{0,17}$
2	Q _{0,17}	qu	$y + C(Q)_{0,17}$
3	none	du	none; y becomes the upper 18 bits of the 36-bit zero filled operand
4	PPR.IC	ic	$y + C(PPR.IC)$
5	A _{18,35}	al	$y + C(A)_{18,35}$
6	Q _{18,35}	ql	$y + C(Q)_{18,35}$
7	none	dl	none; y becomes the lower 18 bits of the 36-bit zero filled operand
10	X0	0, x0	$y + C(X0)$
11	X1	1, x1	$y + C(X1)$
12	X2	2, x2	$y + C(X2)$
13	X3	3, x3	$y + C(X3)$
14	X4	4, x4	$y + C(X4)$
15	X5	5, x5	$y + C(X5)$
16	X6	6, x6	$y + C(X6)$
17	X7	7, x7	$y + C(X7)$

Examples:

	<u>Location</u>	<u>Instruction</u>	<u>Computed address</u>
1.	a	lda y	y
2.	a	sta y,n	y
3.	a	ldaq y,au	$y + C(A)_{0,17}$
4.	a	tra 3,ic	a + 3
5.	a	ldq y,du	none; operand has the form $y (00\dots 0)_{18}$
6.	a	lx14 y,dl	none; operand has the form $(00\dots 0)_{18} y$
7.	a	mpy y,1	$y + C(X1)$
8.	a	stx4 y,7	$y + C(X7)$

Register Then Indirect (ri) Modifications

In register then indirect modification ($T_m = 1$) the value of T_d designates a register whose contents are to be added to $C(TPR.CA)$ to form a modified $C(TPR.CA)$. This modified $C(TPR.CA)$ is used as a computed address to fetch an indirect word. The ADDRESS field of the indirect word is loaded into $TPR.CA$ and the TAG field of the indirect word is interpreted in the next step of an indirect chain. The TALLY field of the indirect word is ignored.

The indirect chain continues until an indirect word TAG field specifies a modification without indirection.

The coding symbol for register then indirect modification is r^* where r is any of the coding symbols for register modification as given in Table 6-1 above except du and dl . The du and dl register codes are illegal and their use causes an illegal procedure, illegal modifier, fault. See Figure 6-4, Table 6-1, and the examples following.

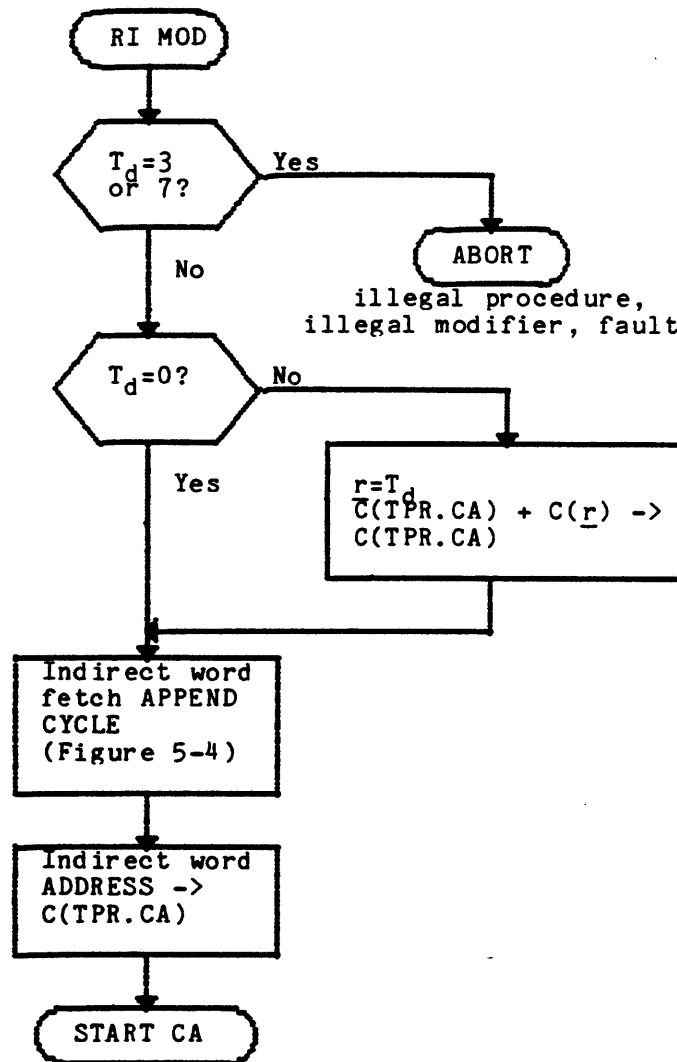

(Figure 6-2)

Figure 6-4. Register Then Indirect Modification Flowchart

Examples:

	<u>Location</u>	<u>Instruction</u>	<u>Computed address</u>
1.	a b	lda b,* arg y	(<u>r</u> = null) y
2.	a b+C(X1)	ldq b,1* arg y,au	y + C(A) _{0,17}
3.	a a+4 c	tra 4,ic* arg c,* arg y	y
4.	a b+C(X0) c+C(X1)	lx14 b,0* arg c,1* arg y,d1	none; operand has the form (00...0) ₁₈ iy

Indirect Then Register (ir) Modification

In indirect then register modification ($T_m = 3$) the value of T_d designates a register whose contents are to be added to $C(TPR.CA)$ to form the final modified $C(TPR.CA)$ during the last step in the indirect chain. The value of T_d is held in a special holding register, CT-HOLD. The initial $C(TPR.CA)$ is used as a computed address to fetch an indirect word. The ADDRESS of the indirect word is loaded into $TPR.CA$ and the TAG field of the indirect word is interpreted in the next step of an indirect chain. The TALLY field of the indirect word is ignored.

If the indirect word TAG field specifies a register then indirect modification, that modification is performed and the indirect chain continues.

If the indirect word TAG field specifies indirect then register modification, the T_d value from that TAG field replaces the T_d value in CT-HOLD and the indirect chain continues.

If the indirect word TAG specifies register or indirect then tally modification, that modification is replaced with a register modification using the T_d value in CT-HOLD and the indirect chain ends.

The coding symbol for indirect then register modification is $*r$ where r is any of the coding symbols for register modification as given in Table 6-2 except null. See Figure 6-5, Table 6-1, and the examples following.

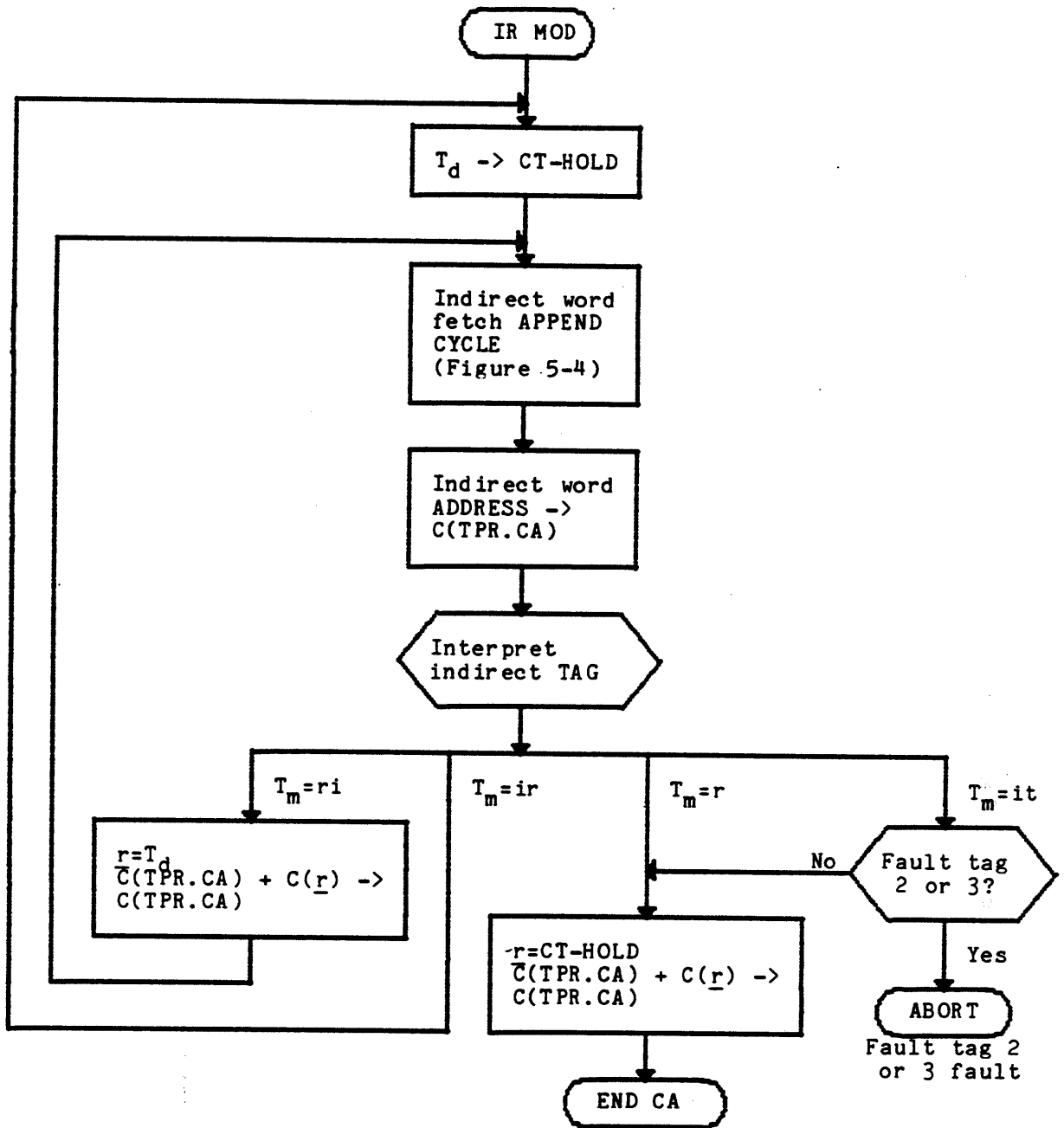

Figure 6-5. Indirect Then Register Modification Flowchart

Examples:

	<u>Location</u>	<u>Instruction</u>	<u>Computed address</u>
1.	a	lda b,*n	(CT-HOLD = n)
	b	arg y,2	y
2.	a	lxl2 b,*d1	(CT-HOLD = d1)
	b	sta y,au	none; operand has the form (00...0) ₁₈ iiy

3.	a	lda b,*1	(CT-HOLD = x1)
	b	arg c,n*	
	c	arg d,*4	(CT-HOLD = x4)
	d	arg y,q1	y + C(X4)
4.	a	ldx0 b,1*	
	b+C(X1)	arg c,*ic	(CT-HOLD = ic)
	c	arg 5,d1	a + 5

Indirect Then Tally (it) Modification

In indirect then tally modification ($T_m = 2$) the value of T_d specifies a variation. The initial C(TPR.CA) is used as an as computed address to fetch an indirect word. The indirect word is interpreted and possibly altered as the modification is performed. If the specified variation involves alteration of the indirect word, the indirect word is fetched with a special main memory cycle that prevents other processors from accessing it until the alteration is complete.

The TALLY field of the indirect word is used to count references made to the indirect word. It has a maximum range of 4096. If the TALLY field has the value 0 after a reference to the indirect word, the tally runout indicator will be set ON, otherwise the tally runout indicator is set OFF. The value of the TALLY field and the state of the tally runout indicator have no effect on computed address formation.

If there is more than one indirect word in an indirect chain that is referenced by a tally counting variation, only the state of the TALLY field of the last such word is reflected in the tally runout indicator.

The variations of the indirect then tally modification are given in Table 6-3 and explained in detail in the paragraphs following. Those entries given as "Undefined" cause an illegal procedure, illegal modifier, fault. See Figure 6-6, Table 6-1, and the examples following.

Table 6-3. Variations of Indirect Then Tally Modification

T _d value	Coding symbol	Computed address
0	f1	Fault tag 1
1		Undefined (see itp modification later in this section)
2		Undefined
3		Undefined (see its modification later in this section)
4	sd	Subtract delta
5	scr	Sequence character reverse
6	f2	Fault tag 2
7	f3	Fault tag 3
10	ci	Character indirect
11	i	Indirect
12	sc	Sequence character
13	ad	Add delta
14	di	Decrement address, increment tally
15	dic	Decrement address, increment tally, and continue
16	id	Increment address, decrement tally
17	idc	Increment address, decrement tally, and continue

Fault tag 1 (T_d = 0)

If this variation appears in an indirect word and the TAG of the instruction word or preceding indirect word is indirect then register (ir), then terminate computed address formation with a register (r) modification using the register held in CT-HOLD. If this variation appears in an instruction word or in an indirect word and the TAG of the instruction word or preceding indirect word is not indirect then register (ir), then generate a fault tag 1 fault.

C(TPR.CA) at the time of the fault contains the computed address of the word containing the fault tag 1 variation. Thus, the ADDRESS and TALLY fields of that word may contain information relative to recovery from the fault.

Subtract delta (T_d = 4)

The TAG field of the indirect word is interpreted as a 6-bit, unsigned, positive address increment value, delta. For each reference to the indirect word, the ADDRESS field is reduced by delta and the TALLY field is increased by 1 before the computed address is formed. ADDRESS arithmetic is modulo 2¹⁰. TALLY arithmetic is modulo 4096. If the TALLY field overflows to 0, the tally runout indicator is set ON, otherwise it is set OFF. The computed address is the value of the decremented ADDRESS field of the indirect word.

Example:

<u>Location</u>	<u>Instruction</u>	<u>Reference count</u>	<u>Computed address</u>	<u>Tally value</u>
a	lda b,sd	1	c-d	t+1
b	vfd 18/c,12/t,6/d	2	c-2d	t+2
		3	c-3d	t+3
		...		
		<u>n</u>	c- <u>nd</u>	t+ <u>n</u>

Sequence character reverse ($T_d = 5$)

Bit 30 of the TAG field of the indirect word is interpreted as a character size flag, t_b , with the value 0 indicating 6-bit characters and the value 1 indicating 9-bit bytes. Bits 33-35 of the TAG field are interpreted as a 3-bit character/byte position counter, c_f . Bits 31-32 of the TAG field must be zero.

For each reference to the indirect word, the character counter, c_f , is reduced by 1 and the TALLY field is increased by 1 before the computed address is formed. Character count arithmetic is modulo 6 for 6-bit characters and modulo 4 for 9-bit bytes. If the character count, c_f , underflows to -1, it is reset to 5 for 6-bit characters or to 3 for 9-bit bytes and ADDRESS is reduced by 1. ADDRESS arithmetic is modulo 2¹⁸. TALLY arithmetic is modulo 4096. If the TALLY field overflows to 0, the tally runout indicator is set ON, otherwise it is set OFF. The computed address is the (possibly) decremented value of the ADDRESS field of the indirect word. The effective character/byte number is the decremented value of the character position count, c_f , field of the indirect word.

A 36-bit operand is formed by high-order zero filling the value of character c_f-1 of C(computed address) with an appropriate number of bits.

Examples:

<u>Location</u>	<u>Instruction</u>	<u>Reference count</u>	<u>cf</u>	<u>Computed address</u>	<u>Tally value</u>	<u>Operand</u>
a	lda b,scr	1	2	c+1	t+1 (00...0)	30 "I"
b	vfd 18/c+1,12/t,1/0,5/3	2	1	c+1	t+2 (00...0)	30 "H"
c	bci "ABCDEFGHijkl"	3	0	c+1	t+3 (00...0)	30 "G"
		4	5	c	t+4 (00...0)	30 "F"
		5	4	c	t+5 (00...0)	30 "E"
		...				
a	lda b,scr	1	2	c+1	t+1 (00...0)	27 "g"
b	vfd 18/c+1,12/t,1/1,5/3	2	1	c+1	t+2 (00...0)	27 "f"
c	aci "abcdefgh"	3	0	c+1	t+3 (00...0)	27 "e"
		4	3	c	t+4 (00...0)	27 "d"
		5	2	c	t+5 (00...0)	27 "c"
		...				

Fault tag 2 ($T_d = 6$)

Terminate computed address formation immediately and generate a fault tag 2 fault.

C(TPR.CA) at the time of the fault contains the computed address of the word containing the fault tag 2 variation. Thus, the ADDRESS and TALLY fields of that word may contain information relative to recovery from the fault.

Fault tag 3 ($T_d = 7$)

Terminate computed address formation immediately and generate a fault tag 3 fault.

C(TPR.CA) at the time of the fault contains the computed address of the word containing the fault tag 3 variation. Thus, the ADDRESS and TALLY fields of that word may contain information relative to recovery from the fault.

Character indirect ($T_d = 10$)

Bit 30 of the TAG field of the indirect word is interpreted as a character size flag, *tb*, with the value 0 indicating 6-bit characters and the value 1 indicating 9-bit bytes. Bits 33-35 of the TAG field are interpreted as a 3-bit character/byte position value, *cf*. Bits 31-32 of the TAG field must be zero.

If the character position value is greater than 5 for 6-bit characters or greater than 3 for 9-bit bytes, an illegal procedure, illegal modifier, fault will occur. The TALLY field is ignored. The computed address is the value of the ADDRESS field of the indirect word. The effective character/byte number is the value of the character position count, *cf*, field of the indirect word.

A 36-bit operand is formed by high-order zero filling the value of character *cf* of C(computed address) with an appropriate number of bits.

Examples:

<u>Location</u>	<u>Instruction</u>	<u>Operand</u>
a	lda b,ci	
b	vfd 18/c+1,12/0,1/0,5/2	(00...0) ₃₀ "I"
c	bci "ABCDEFGHijkl"	
a	lda d,ci	
d	vfd 18/c,12/0,1/0,5/1	(00...0) ₃₀ "B"
a	lda e,ci	
e	vfd 18/f,12/0,1/1,5/3	(00...0) ₂₇ "d"
f	aci "abcdefgh"	
a	lda g,ci	
g	vfd 18/f+1,12/0,1/1,5/0	(00...0) ₂₇ "e"

Indirect ($T_d = 11$)

The computed address is the value of the ADDRESS field of the indirect word. The TALLY and TAG fields of the indirect word are ignored.

Sequence character ($T_d = 12$)

Bit 30 of the TAG field of the indirect word is interpreted as a character size flag, *tb*, with the value 0 indicating 6-bit characters and the value 1 indicating 9-bit bytes. Bits 33-35 of the TAG field are interpreted as a 3-bit character position counter, *cf*. Bits 31-32 of the TAG field must be zero.

For each reference to the indirect word, the character counter, *cf*, is increased by 1 and the TALLY field is reduced by 1 after the computed address is formed. Character count arithmetic is modulo 6 for 6-bit characters and modulo 4 for 9-bit bytes. If the character count, *cf*, overflows to 6 for 6-bit characters or to 4 for 9-bit bytes, it is reset to 0 and ADDRESS is increased by 1. ADDRESS arithmetic is

modulo 2^{18} . TALLY arithmetic is modulo 4096. If the TALLY field is reduced to 0, the tally runout indicator is set ON, otherwise it is set OFF. The computed address is the unmodified value of the ADDRESS field. The effective character/byte number is the unmodified value of the character position counter, cf, field of the indirect word.

A 36-bit operand is formed by high-order zero filling the value of character cf of C(computed address) with an appropriate number of bits.

Examples:

<u>Location</u>	<u>Instruction</u>	<u>Reference count</u>	<u>cf</u>	<u>Computed address</u>	<u>Tally value</u>	<u>Operand</u>
a	lda b,sc	1	4	c	t-1 (00...0)	30 "E"
b	vfd 18/c,12/t,1/0,5/4	2	5	c	t-2 (00...0)	30 "F"
c	bci "ABCDEFGHijkl"	3	0	c+1	t-3 (00...0)	30 "G"
		4	1	c+1	t-4 (00...0)	30 "H"
		5	2	c+1	t-5 (00...0)	30 "I"
		...				
a	lda b,sc	1	2	c	t-1 (00...0)	27 "c"
b	vfd 18/c,12/t,1/1,5/2	2	3	c	t-2 (00...0)	27 "d"
c	aci "abcdefgh"	3	0	c+1	t-3 (00...0)	27 "e"
		4	1	c+1	t-4 (00...0)	27 "f"
		5	2	c+1	t-5 (00...0)	27 "g"
		...				

Add delta ($T_d = 13$)

The TAG field of the indirect word is interpreted as a 6-bit, unsigned, positive address increment value, delta. For each reference to the indirect word, the ADDRESS field is increased by delta and the TALLY field is reduced by 1 after the computed address is formed. ADDRESS arithmetic is modulo 2^{18} . TALLY arithmetic is modulo 4096. If the TALLY field is reduced to 0, the tally runout indicator is set ON, otherwise it is set OFF. The computed address is the value of the unmodified ADDRESS field of the indirect word.

Example:

<u>Location</u>	<u>Instruction</u>	<u>Reference count</u>	<u>Computed address</u>	<u>Tally value</u>
a	lda b,ad	1	c	t-1
b	vfd 18/c,1/t,6/d	2	c+d	t-2
		3	c+2d	t-3
		...		
		<u>n</u>	c+(<u>n</u> -1)d	t- <u>n</u>

Decrement address, increment tally ($T_d = 14$)

For each reference to the indirect word, the ADDRESS field is reduced by 1 and the TALLY field is increased by 1 before the computed address is formed. ADDRESS arithmetic is modulo 2^{18} . TALLY arithmetic is modulo 4096. If the TALLY field overflows to 0, the tally runout indicator is set ON, otherwise it is set OFF. The TAG field of the indirect word is ignored. The computed address is the value of the decremented ADDRESS field.

Example:

<u>Location</u>	<u>Instruction</u>	<u>Reference count</u>	<u>Computed address</u>	<u>Tally value</u>
a	lda b,di	1	c-1	t+1
b	vfd 18/c,12/t	2	c-2	t+2
		3	c-3	t+3
		...		
		<u>n</u>	<u>c-n</u>	<u>t+n</u>

Decrement address, increment tally, and continue ($T_d = 15$)

The action for this variation is identical to that for the decrement address, increment tally variation except that the TAG field of the indirect word is interpreted and continuation of the indirect chain is possible. If the TAG of the indirect word invokes a register, that is, specifies r, ri, or ir modification, the effective T_d value for the register is forced to "null" before the next computed address is formed.

Increment address, decrement tally ($T_d = 16$)

For each reference to the indirect word, the ADDRESS field is increased by 1 and the TALLY field is reduced by 1 after the computed address is formed. ADDRESS arithmetic is modulo 2^{18} . TALLY arithmetic is modulo 4096. If the TALLY field is reduced to 0, the tally runout indicator is set ON, otherwise it is set OFF. The TAG field of the indirect word is ignored. The computed address is the value of the unmodified ADDRESS field.

Example:

<u>Location</u>	<u>Instruction</u>	<u>Reference count</u>	<u>Computed address</u>	<u>Tally value</u>
a	lda b,id	1	c	t-1
b	vfd 18/c,1/t	2	c+1	t-2
		3	c+2	t-3
		...		
		<u>n</u>	<u>c+(n-1)</u>	<u>t-n</u>

Increment address, decrement tally, and continue ($T_d = 17$)

The action for this variation is identical to that for the increment address, decrement tally variation except that the TAG field of the indirect word is interpreted and continuation of the indirect chain is possible. If the TAG of the indirect word invokes a register, that is, specifies r, ri, or ir modification, the effective T_d value for the register is forced to "null" before the next computed address is formed.

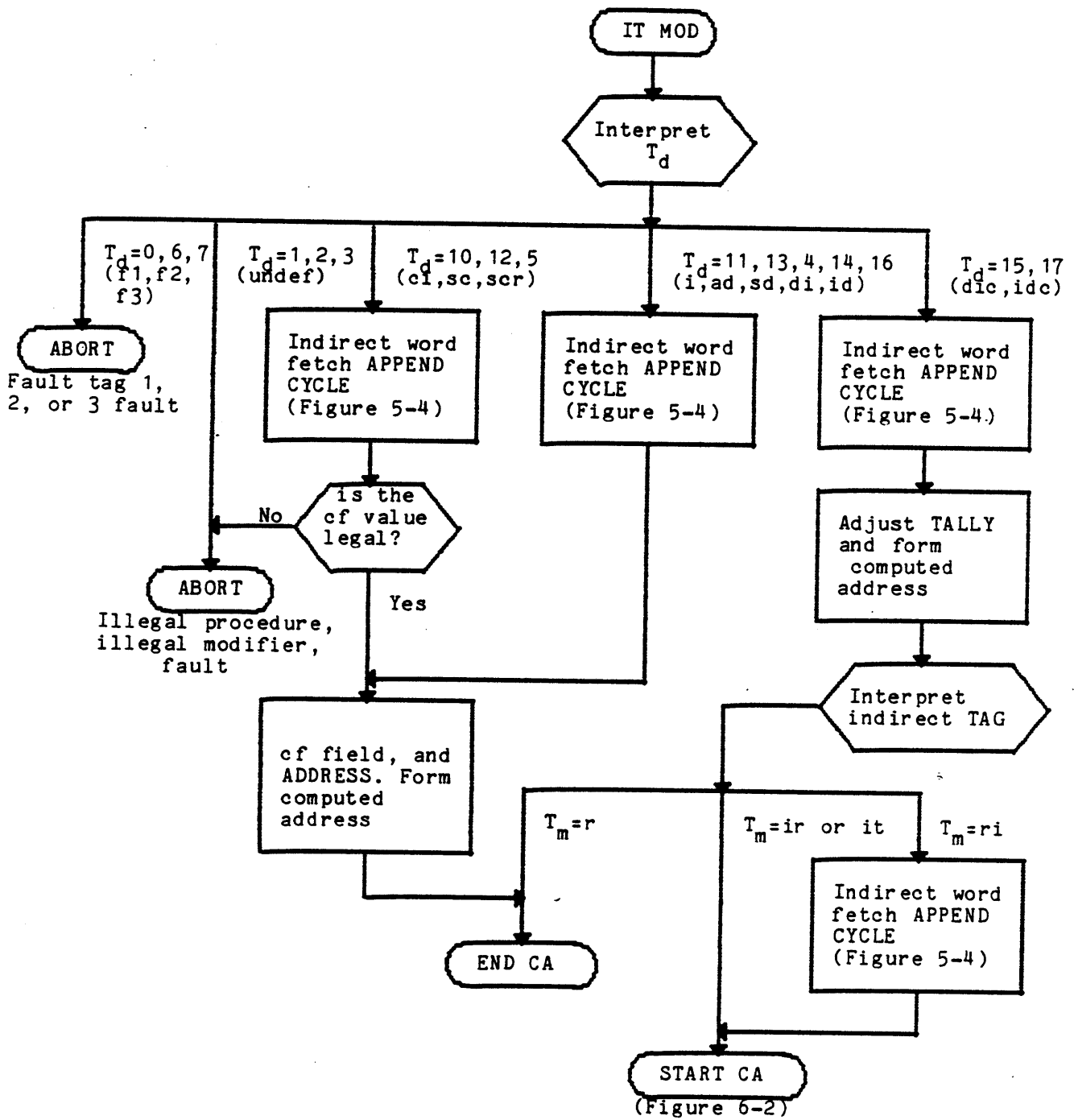

Figure 6-6. Indirect Then Tally Modification Flowchart

VIRTUAL ADDRESS FORMATION INVOLVING BOTH SEGMENT NUMBER AND COMPUTED ADDRESS

The second type of virtual address formation generates an effective segment number and a computed address simultaneously.

The Use of Bit 29 in the Instruction Word

The reader is reminded that there is a preliminary step of loading TPR.CA with the ADDRESS field of the instruction word during instruction decode.

If bit 29 of the instruction word is set to 1, modification by pointer register is invoked and the preliminary step is executed as follows:

1. The ADDRESS field of the instruction word is interpreted as shown in Figure 6-7 below.
2. $C(PR_n.SNR) \rightarrow C(TPR.TSR)$
3. maximum of $[C(PR_n.RNR), C(TPR.TRR), C(PPR.PRR)] \rightarrow C(TPR.TRR)$
4. $C(PR_n.WORDNO) + OFFSET \rightarrow C(TPR.CA)$
(NOTE: OFFSET is a signed binary number.)
5. $C(PR_n.BITNO) \rightarrow TPR.BITNO$

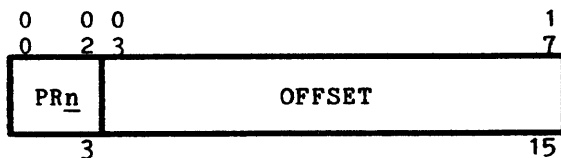

Figure 6-7. Format of Instruction Word ADDRESS When Bit 29 = 1

After this preliminary step is performed, virtual address formation proceeds as discussed above or as discussed for the special address modifiers below.

Special Address Modifiers

Whenever the processor is forming a virtual address two special address modifiers may be specified and are effective under certain restrictive conditions. The special address modifiers are shown in Table 6-4 and discussed in the paragraphs below.

The conditions for which the special address modifiers are effective are as follows:

1. The instruction word (or preceding indirect word) must specify indirect then register or register then indirect modification.
2. The computed address for the indirect word must be even.

If these conditions are satisfied, the processor examines the indirect word TAG field for the special address modifiers.

If either condition is violated, the indirect word TAG field is interpreted as a normal address modifier and the presence of a special address modifier will cause an illegal procedure, illegal modifier, fault.

Table 6-4. Special Address Modifiers

TAG Value	Coding Symbol	Name
41	ITP	Indirect to pointer
43	ITS	Indirect to segment

Indirect to Pointer (ITP) Modification

If the value for indirect to pointer modification is found in the test for special modifiers, the indirect word-pair is interpreted as an ITP pointer pair (see Figure 6-8 for format) and the following actions take place:

For $\underline{n} = C(\text{ITP.PRNUM})$:

$C(\text{PR}_{\underline{n}}.\text{SNR}) \rightarrow C(\text{TPR.TSR})$

maximum of $[C(\text{PR}_{\underline{n}}.\text{RNR}), C(\text{SDW.R1}), C(\text{TPR.TRR})] \rightarrow C(\text{TPR.TRR})$

$C(\text{ITP.BITNO}) \rightarrow C(\text{TPR.TBR})$

$C(\text{PR}_{\underline{n}}.\text{WORDNO}) + C(\text{ITP.WORDNO}) + C(\underline{r}) \rightarrow C(\text{TPR.CA})$

where:

1. $\underline{r} = C(\text{CT-HOLD})$ if the instruction word or preceding indirect word specified indirect then register modification, or
2. $\underline{r} = C(\text{ITP.MOD.T}_d)$ if the instruction word or preceding indirect word specified register then indirect modification and ITP.MOD.T_m specifies either register or register then indirect modification.
3. SDW.R1 is the upper limit of the read/write ring bracket for the segment $C(\text{PR}_{\underline{n}}.\text{SNR})$ (see Section 8).

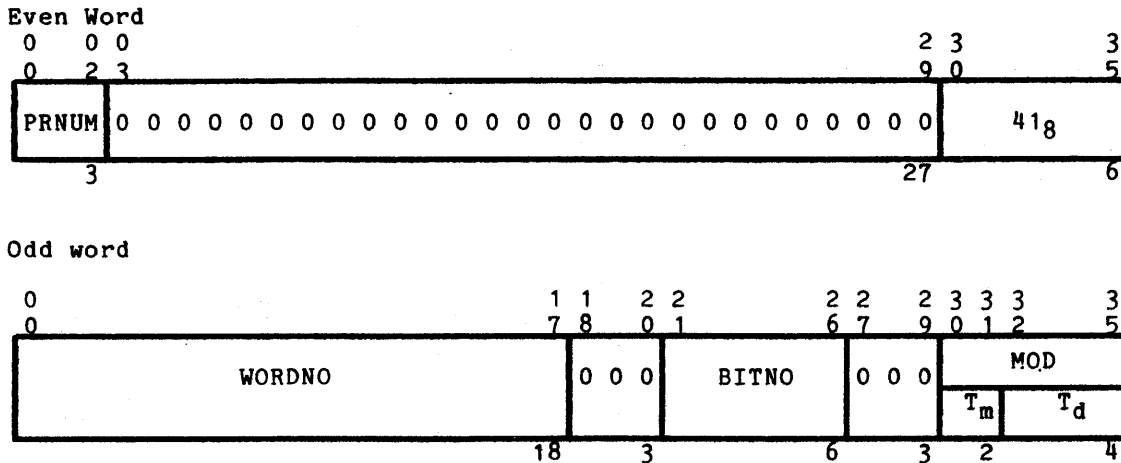

Figure 6-8. ITP Pointer Pair Format

Field Name	Meaning
PRNUM	The number of the pointer register through which to make the segment reference
WORDNO	A word offset value to be added to C(PR _n .WORDNO)
BITNO	A bit offset value for the data item
MOD	Any normal address modifier (<u>not</u> ITP or ITS)

Indirect to Segment (ITS) Modification

If the value for indirect to segment modification is found in the test for special modifiers, the indirect word-pair is interpreted as an ITS pointer pair (see Figure 6-9 for format) and the following actions take place:

$C(ITS.SEGNO) \rightarrow C(TPR.TSR)$
 maximum of $[C(ITS.RN), C(SDW.R1), C(TPR.TRR)] \rightarrow C(TPR.TRR)$
 $C(ITS.BITNO) \rightarrow C(TPR.TBR)$
 $C(ITS.WORDNO) + C(\underline{r}) \rightarrow C(TPR.CA)$

where:

1. $\underline{r} = C(CT-HOLD)$ if the instruction word or preceding indirect word specified indirect then register modification, or
2. $\underline{r} = C(ITS.MOD.T_d)$ if the instruction word or preceding indirect word specified register then indirect modification and ITS.MOD.T_m specifies either register or register then indirect modification.
3. SDW.R1 is the upper limit of the read/write ring bracket for the segment C(ITS.SEGNO) (see Section 8).

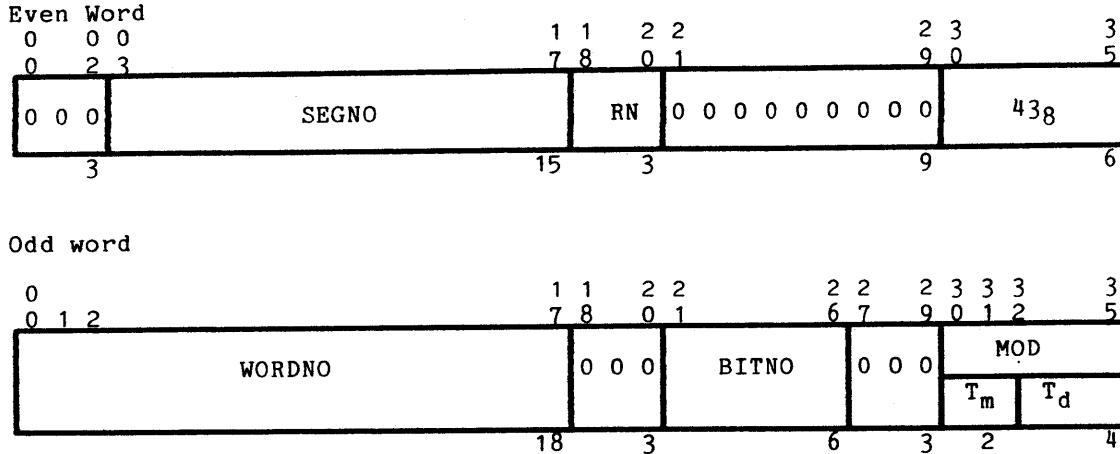

Figure 6-9. ITS Pointer Pair Format

Field Name	Meaning
SEGNO	The number of the segment to be referenced
WORDNO	Word offset to be used in the computed address formation
BITNO	The bit offset for the data item
MOD	Any valid normal address modifier (<u>not</u> ITS or ITP)

Effective Segment Number Generation

A simplified flowchart for effective segment number generation is given in Figure 6-10. Although effective ring number generation and access checking are an integral part of this process, their treatment is deferred to Section 8.

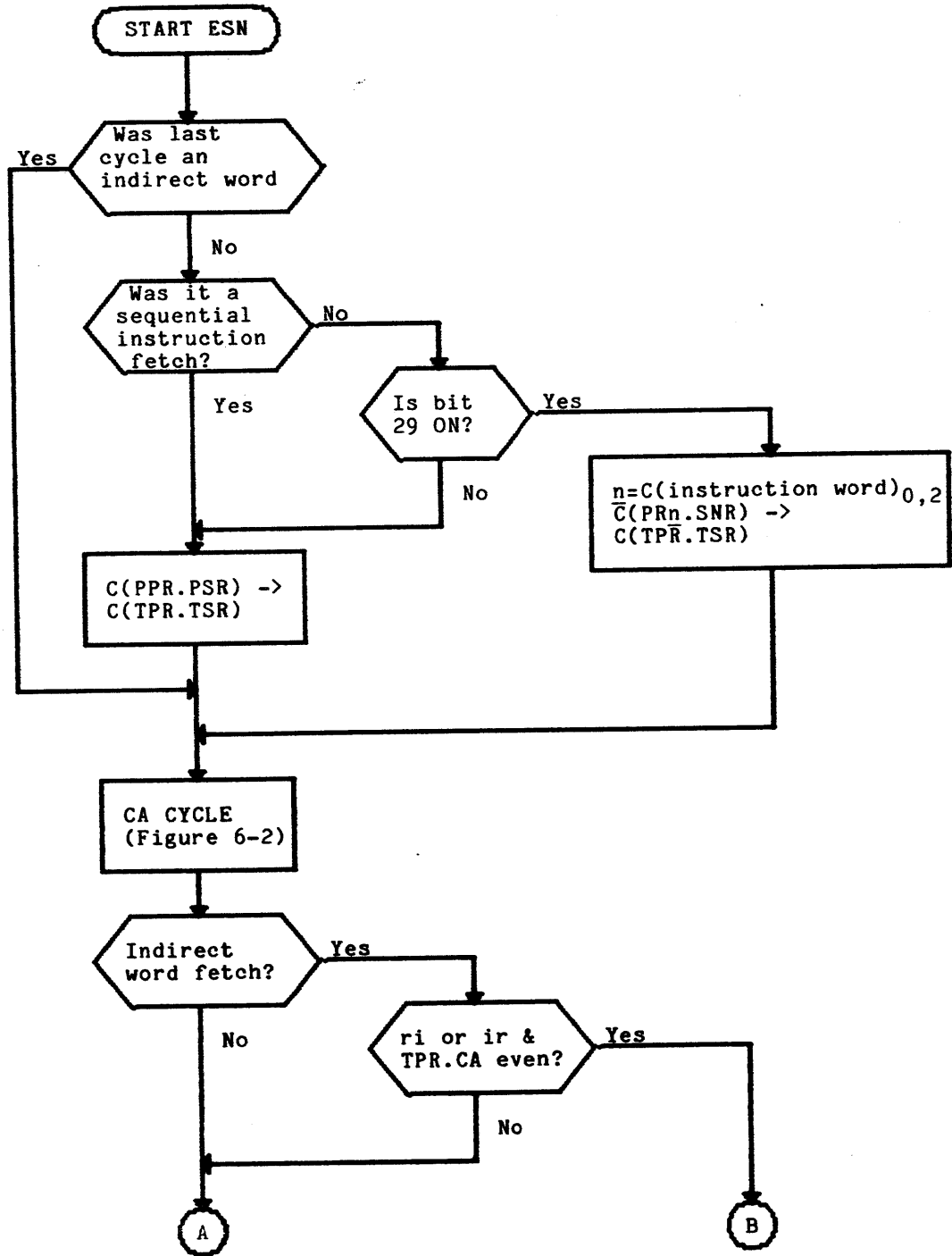
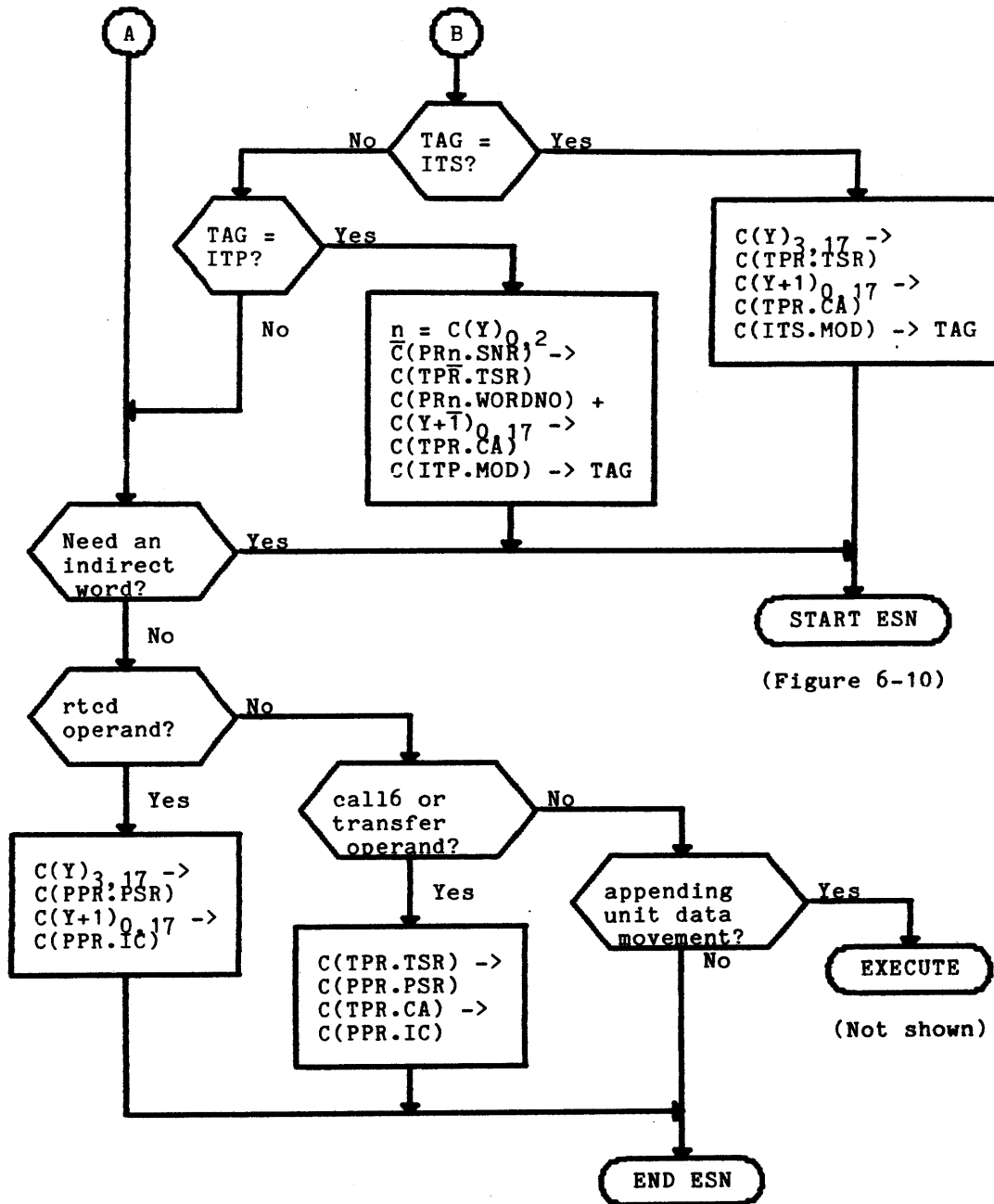

Figure 6-10. Effective Segment Generation Flowchart



(Figure 6-10)

Figure 6-10(cont). Effective Segment Number Generation Flowchart

VIRTUAL ADDRESS FORMATION FOR EXTENDED INSTRUCTION SET

The steps involved in virtual address formation for the operand of an EIS instruction are shown in Figure 6-11. The flowchart depicts the virtual address formation for operand k as described by its modification field, MF_k . This virtual address formation is performed for each operand as its operand descriptor is decoded.

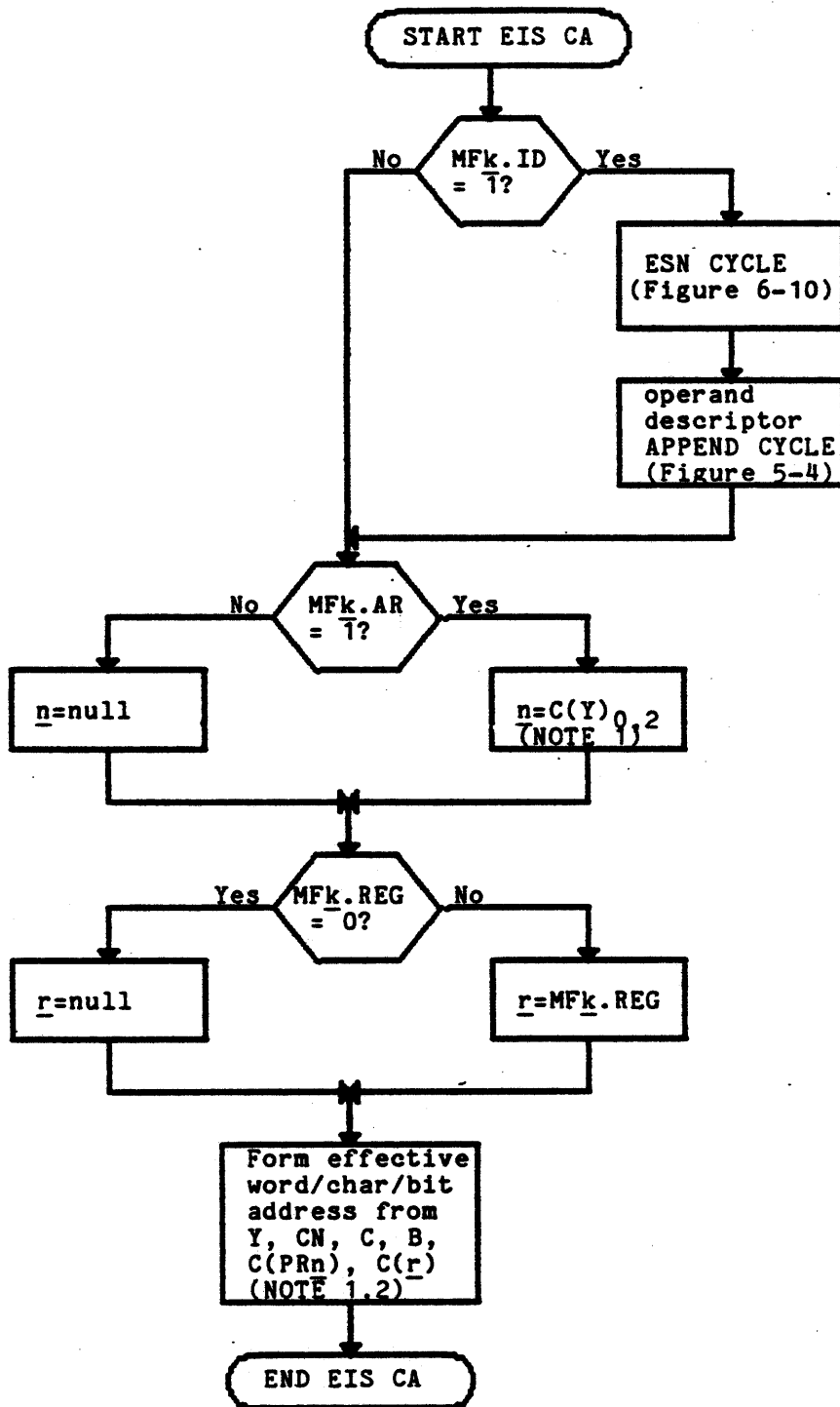

Figure 6-11. EIS Virtual Address Formation Flowchart

NOTE 1: The symbol "Y" stands for the contents of the ADDRESS field of the operand descriptor. The symbols "CN" and "C" stand for the contents of the character number field. The symbol "B" stands for the contents of the bit number field.

NOTE 2: The algorithms used in the formation of the effective word/char/bit address are described below.

Character- and Bit-String Addressing

The processor represents the effective address of a character- or bit-string operand in three different forms as follows:

1. Pointer register form

This form consists of a word value ($PR_n.WORDNO$) and a bit value ($PR_n.BITNO$). The word value is the word offset of the word containing the first character or bit of the operand and the bit value is the bit position of that character or bit within the word. This form is seen when $C(PR_n)$ are stored as an its pointer pair or as a packed pointer (see discussion of its pointers earlier in this section and the Store Pointer Register n Packed ($sprpn$) instruction in Section 4).

2. Address register form

This form consists of a word value ($AR_n.WORDNO$), a byte number ($AR_n.CHAR$), and a bit value ($AR_n.BITNO$). The word value is the word offset of the word containing the first character or bit of the operand. The byte number is the number of the 9-bit byte containing the first character or bit. The bit value is the bit position within $AR_n.CHAR$ of the first character or bit. This form is seen when $C(AR_n)$ are stored with the Store Address Register n ($sarn$) instruction (see Section 4).

3. Operand Descriptor Form

This form is valid for character-string operands only. It consists of a word value ($ADDRESS$) and a character number (CN). The word value is the word offset of the word containing the first character of the operand and the character number is the number of that character within the word. This form is seen when $C(AR_n)$ are stored with the Address Register n to Alphanumeric Descriptor ($aran$) or Address Register n to Numeric Descriptor ($arnn$) instructions. (The operand descriptor form for bit-string operands is identical to the address register form.)

The terms "pointer register" and "address register" both apply to the same physical hardware. The distinction arises from the manner in which the register is used and in the interpretation of the register contents. "Pointer register" refers to the register as used by the appending unit and "address register" refers to the register as used by the decimal unit.

The three forms are compatible and may be freely intermixed. For example, PR_n may be loaded in pointer register form with the Effective Pointer to Pointer Register n ($eppn$) instruction, then modified in pointer register form with the Effective Address to Word/Bit Number of Pointer Register n ($eawpn$) instruction, then further modified in address register form (assuming character size k) with the Add k -Bit Displacement to Address Register ($akbd$) instruction, and finally invoked in operand descriptor form by the use of $MF.AR$ in an EIS multiword instruction.

Character- and Bit-String Address Arithmetic Algorithms

The arithmetic algorithms for calculating character- and bit-string addresses are presented below. The symbols "ADDRESS" and "CN" represent the ADDRESS and CN fields of the operand descriptor being decoded. " r " and " n " are set according to the flowchart in Figure 6-11. If either has the value "null", the contents of all associated fields are identically zero.

9-BIT BYTE STRING ADDRESS ARITHMETIC

$$\begin{aligned}\text{Effective BITNO} &= 0000 \\ \text{Effective CHAR} &= (\text{CN} + \text{C}(\text{AR}_n.\text{CHAR}) + \text{C}(\underline{r})) \boxed{4} \\ \text{Effective WORDNO} &= \text{ADDRESS} + \text{C}(\text{AR}_n.\text{WORDNO}) + \\ &\quad (\text{CN} + \text{C}(\text{AR}_n.\text{CHAR}) + \text{C}(\underline{r})) / 4\end{aligned}$$

6-BIT CHARACTER STRING ADDRESS ARITHMETIC

$$\begin{aligned}\text{Effective BITNO} &= (9*\text{C}(\text{AR}_n.\text{CHAR}) + 6*\text{C}(\underline{r}) + \text{C}(\text{AR}_n.\text{BITNO})) \boxed{9} \\ \text{Effective CHAR} &= ((9*\text{C}(\text{AR}_n.\text{CHAR}) + 6*\text{C}(\underline{r}) + \text{C}(\text{AR}_n.\text{BITNO})) \boxed{36}) / 9 \\ \text{Effective WORDNO} &= \text{ADDRESS} + \text{C}(\text{AR}_n.\text{WORDNO}) + \\ &\quad (9*\text{C}(\text{AR}_n.\text{CHAR}) + 6*\text{C}(\underline{r}) + \text{C}(\text{AR}_n.\text{BITNO})) / 36\end{aligned}$$

4-BIT BYTE STRING ADDRESS ARITHMETIC

$$\begin{aligned}\text{Effective BITNO} &= 4 * (\text{C}(\text{AR}_n.\text{CHAR}) + 2*\text{C}(\underline{r}) + \text{C}(\text{AR}_n.\text{BITNO})/4) \boxed{2} + 1 \\ \text{Effective CHAR} &= ((9*\text{C}(\text{AR}_n.\text{CHAR}) + 4*\text{C}(\underline{r}) + \text{C}(\text{AR}_n.\text{BITNO})) \boxed{36}) / 9 \\ \text{Effective WORDNO} &= \text{ADDRESS} + \text{C}(\text{AR}_n.\text{WORDNO}) + \\ &\quad (9*\text{C}(\text{AR}_n.\text{CHAR}) + 4*\text{C}(\underline{r}) + \text{C}(\text{AR}_n.\text{BITNO})) / 36\end{aligned}$$

BIT STRING ADDRESS ARITHMETIC

$$\begin{aligned}\text{Effective BITNO} &= (9*\text{C}(\text{AR}_n.\text{CHAR}) + 36*\text{C}(\underline{r}) + \text{C}(\text{AR}_n.\text{BITNO})) \boxed{9} \\ \text{Effective CHAR} &= ((9*\text{C}(\text{AR}_n.\text{CHAR}) + 36*\text{C}(\underline{r}) + \text{C}(\text{AR}_n.\text{BITNO})) \boxed{36}) / 9 \\ \text{Effective WORDNO} &= \text{ADDRESS} + \text{C}(\text{AR}_n.\text{WORDNO}) + \\ &\quad (9*\text{C}(\text{AR}_n.\text{CHAR}) + 36*\text{C}(\underline{r}) + \text{C}(\text{AR}_n.\text{BITNO})) / 36\end{aligned}$$

SECTION 7

FAULTS AND INTERRUPTS

Faults and interrupts both result in an interruption of normal sequential processing, but there is a difference in how they originate. Generally, faults are caused by events or conditions that are internal to the processor and interrupts are caused by events or conditions that are external to the processor. Faults and interrupts enable the processor to respond promptly when conditions occur that require system attention.

A unique word-pair is dedicated for the instructions to service each fault and interrupt condition. The instruction pair associated with a fault or interrupt is called the trap pair for that fault or interrupt. The set of all interrupt trap pairs is called the interrupt vector and is located at absolute main memory address 0. The set of all fault trap pairs is called the fault vector and is located at a 0 modulo 32 absolute main memory address whose high-order bits are given by the setting of the FAULT BASE switches on the processor configuration panel. The fault vector is constrained to lie within the lowest 4096 words of main memory.

FAULT CYCLE SEQUENCE

Following the detection of a fault condition, the control unit determines the proper time to initiate the fault sequence according to the fault group (Fault groups are discussed later in this section). At that time, the control unit interrupts normal sequential processing with an ABORT CYCLE. The ABORT CYCLE brings all overlapped and asynchronous functions within the processor to an orderly halt. At the end of the ABORT CYCLE, the control unit initiates a FAULT CYCLE.

In the FAULT CYCLE, the processor safe-stores the Control Unit Data (see Section 3) into program-invisible holding registers in preparation for a Store Control Unit (scu) instruction, then enters temporary absolute mode, forces the current ring of execution C(PPR.PRR) to 0, and generates a computed address for the fault trap pair by concatenating the setting of the FAULT BASE switches on the processor configuration panel with twice the fault number (see Table 7-1). This computed address and the operation code for the Execute Double (xed) instruction are forced into the instruction register and executed as an instruction. Note that the execution of the instruction is not done in a normal EXECUTE CYCLE but in the FAULT CYCLE with the processor in temporary absolute mode.

If the attempt to fetch and execute the instruction pair at the fault trap pair results in another fault, the current FAULT CYCLE is aborted and a new FAULT CYCLE for the trouble fault (fault number 31) is initiated. In the FAULT CYCLE for a trouble fault, the processor does not safe-store the Control Unit Data. Therefore, it may be possible to recover the conditions for the original fault (except the fault number) by use of the Store Control Unit (scu) instruction. The fault number may usually be recovered by analysis of the computed address for the original fault trap pair stored in the control unit history registers.

If either of the two instructions in the fault trap pair results in a transfer of control to a computed address generated in absolute mode, the absolute mode indicator is set ON for the transfer and remains ON thereafter until changed by program action.

If either of the two instructions in the fault trap pair results in a transfer of control to a computed address generated in append mode (through the use of bit 29 of the instruction word or by use of the its or itp modifiers), the transfer is made in the append mode and the processor remains in append mode thereafter.

If no transfer of control takes place, the processor returns to the mode in effect at the time of the fault and resumes normal sequential execution with the instruction following the faulting instruction ($C(PPR.IC) + 1$). Note that the current ring of execution $C(PPR.PRR)$ was forced to 0 during the FAULT CYCLE and that normal sequential execution will resume in ring 0.

Many of the fault conditions are deliberately or inadvertently caused by the software and do not necessarily involve error conditions. The operating supervisor determines the proper action for each fault condition by analyzing the detailed state of the processor at the time of the fault. In order to accomplish this analysis, it is necessary that the first instruction in each of the fault trap pairs be the Store Control Unit (scu) instruction and the second be a transfer to a fault analysis routine. If a fault condition is to be intentionally ignored, the fault trap pair for that condition should contain an scu/rcu pair referencing a unique Y-block8. By using this pair to ignore a fault, the state of the processor for the ignored fault condition may be recovered if the ignored fault causes a trouble fault. The use of the scu/rcu pair also ensures that execution is resumed in the original ring of execution.

Table 7-1. List of Faults

Decimal fault number	Octal ⁽¹⁾ fault address	Fault mnemonic	Fault name	Priority	Group
0	0	sdf	Shutdown	27	7
1	2	str	Store	10	4
2	4	mme	Master mode entry 1	11	5
3	6	f1	Fault tag 1	17	5
4	10	tro	Timer runout	26	7
5	12	cmd	Command	9	4
6	14	drl	Derail	15	5
7	16	luf	Lockup	5	4
8	20	con	Connect	25	7
9	22	par	Parity	8	4
10	24	ipr	Illegal procedure	16	5
11	26	onc	Operation not complete	4	2
12	30	suf	Startup	1	1
13	32	ofl	Overflow	7	3
14	34	div	Divide check	6	3
15	36	exf	Execute	2	1
16	40	df0	Directed fault 0	20	6
17	42	df1	Directed fault 1	21	6
18	44	df2	Directed fault 2	22	6
19	46	df3	Directed fault 3	23	6
20	50	acv	Access violation	24	6
21	52	mme2	Master mode entry 2	12	5
22	54	mme3	Master mode entry 3	13	5
23	56	mme4	Master mode entry 4	14	5
24	60	f2	Fault tag 2	18	5
25	62	f3	Fault tag 3	19	5
26	64		Unassigned		
27	66		Unassigned		
28	70		Unassigned		
29	72		Unassigned		
30	74		Unassigned		
31	76	trb	Trouble	3	2

(1) The octal fault address value is the value concatenated with the FAULT BASE switch setting in forming the computed address for the fault trap pair.

FAULT PRIORITY

The processor has provision for 32 faults of which 27 are implemented. The faults are classified into seven fault priority groups that roughly correspond to the severity of the faults. Fault priority groups are defined so that fault recognition precedence may be established when two or more faults exist concurrently. Overlapped and asynchronous functions in the processor allow the simultaneous occurrence of faults. Group 1 has the highest priority and group 7 has the lowest. In groups 1 through 6, only one fault within each group is allowed to be active at any one time. The first fault within a group occurring through the normal program sequence is the one serviced.

Group 7 faults are saved by the hardware for eventual recognition. In the case of simultaneous faults within group 7, shutdown has the highest priority with timer runout next and connect the lowest.

There is a single exception to the handling of faults in priority group order. If an operand fetch generates a parity fault and the use of the operand in "closing out" instruction execution generates an overflow fault or a divide check fault, these faults are considered simultaneous but the parity fault takes precedence.

FAULT RECOGNITION

For the discussion following, the term "function" is defined as a major processor functional cycle. Examples are: APPEND CYCLE, CA CYCLE, INSTRUCTION FETCH CYCLE, OPERAND STORE CYCLE, DIVIDE EXECUTION CYCLE. Some of these cycles are discussed in various sections of this manual.

Faults in groups 1 and 2 cause the processor to abort all functions immediately by entering a FAULT CYCLE.

Faults in group 3 cause the processor to "close out" current functions without taking any irrevocable action (such as setting PTW.U in an APPEND CYCLE or modifying an indirect word in a CA CYCLE), then to discard any pending functions (such as an APPEND CYCLE needed during a CA CYCLE), and to enter a FAULT CYCLE.

Faults in group 4 cause the processor to suspend overlapped operation, to complete current and pending functions for the current instruction, and then to enter a FAULT CYCLE.

Faults in groups 5 or 6 are normally detected during virtual address formation and instruction decode. These faults cause the processor to suspend overlapped operation, to complete the current and pending instructions, and to enter a FAULT CYCLE. If a fault in a higher priority group is generated by the execution of the current or pending instructions, that higher priority fault will take precedence and the group 5 or 6 fault will be lost. If a group 5 or 6 fault is detected during execution of the current instruction (e.g., an access violation, out of segment bounds, fault during certain interruptable EIS instructions), the instruction is considered "complete" upon detection of the fault.

Faults in group 7 are held and processed (with interrupts) at the completion of the current instruction pair. Group 7 faults are inhibitable by setting bit 28 of the instruction word.

Faults in groups 3 through 6 must wait for the system controller to acknowledge the last access request before entering the FAULT CYCLE.

FAULT DESCRIPTIONS

Group 1 Faults

Startup

DC POWER has been turned on. When the POWER ON button is pressed, the processor is first initialized and then the startup fault is generated.

Execute

1. The EXECUTE pushbutton on the processor maintenance panel has been pressed.
2. An external gate signal has been substituted for the EXECUTE pushbutton.

The selection between the above conditions is made by settings of various switches on the processor maintenance panel.

Group 2 Faults

Operation Not Complete

Any of the following will cause an operation not complete fault:

1. The processor has addressed a system controller to which it is not attached, that is, there is no main memory interface port having its ADDRESS ASSIGNMENT switches set to a value including the main memory address desired.
2. The addressed system controller has failed to acknowledge the processor.
3. The processor has not generated a main memory access request or a direct operand within 1 to 2 milliseconds and is not executing the Delay Until Interrupt Signal (dis) instruction.
4. A main memory interface port received a data strobe without a preceding acknowledgement from the system controller that it had received the access request.
5. A main memory interface port received a data strobe before the data previously sent to it was unloaded.

Trouble

The trouble fault is defined as the occurrence of a fault during the fetch or execution of a fault trap pair or interrupt trap pair. Such faults may be hardware generated (for example, operation not complete or parity), or operating system generated (e.g., the page containing a trap pair instruction operand is missing).

Group 3 Faults

Overflow

An arithmetic overflow, exponent overflow, exponent underflow, or EIS truncation fault has been generated. The generation of this fault is inhibited when the overflow mask indicator is ON. Resetting of the overflow mask indicator to OFF does not generate a fault from previously set indicators. The overflow mask state does not affect the setting, testing or storing of indicators. The determination of the specific overflow condition is by indicator testing by the operating supervisor.

Divide Check

A divide check fault occurs when the actual division cannot be carried out for one of the reasons specified with individual divide instructions.

Group 4 Faults

Store

The processor attempted to select a disabled port, an out-of-bounds address was generated in the BAR mode or absolute mode, or an attempt was made to access a store unit that was not ready.

Command

1. The processor attempted to load or read the interrupt mask register in a system controller in which it did not have an interrupt mask assigned.
2. The processor issued an XEC system controller command to a system controller in which it did not have an interrupt mask assigned.
3. The processor issued a connect to a system controller port that is masked OFF.
4. The selected system controller is in TEST mode and a condition determined by certain system controller maintenance panel switches has been trapped.
5. An attempt was made to load a pointer register with packed pointer data in which the BITNO field value was greater than or equal to 60₍₈₎.

Lockup

The program is in a code sequence which has inhibited sampling for interrupts (whether present or not) and group 7 faults for longer than the prescribed time. In absolute mode or privileged mode the lockup time is 32 milliseconds. In normal mode or BAR mode the lockup time is specified by the setting for the lockup time in the cache mode register. The lockup time is program settable to 2, 4, 8, or 16 milliseconds.

While in absolute mode or privileged mode the lockup fault is signalled at the end of the time limit set in the lockup timer but is not recognized until the 32 millisecond limit. If the processor returns to normal mode or BAR mode after the fault has been signalled but before the 32 millisecond limit, the fault is recognized before any instruction in the new mode is executed.

Parity

1. The selected system controller has returned an illegal action signal with an illegal action code for one of the various main memory parity error conditions.
2. A cache memory data or directory parity error has occurred either for read, write, or block load. Cache status bits for the condition have been set in the cache mode register.

3. The processor has detected a parity error in the system controller interface port while either generating outgoing parity or verifying incoming parity.

Group 5 Faults

Master Mode Entries 1-4

The corresponding Master Mode Entry instruction has been decoded.

Fault Tags 1-3

The corresponding indirect then tally variation has been detected during virtual address formation.

Derail

The Derail instruction has been decoded.

Illegal Procedure

1. An illegal operation code has been decoded or an illegal instruction sequence has been encountered.
2. An illegal modifier or modifier sequence has been encountered during virtual address formation.
3. An illegal address has been given in an instruction for which the ADDRESS field is used for register selection.
4. An attempt was made to execute a privileged instruction in normal mode or BAR mode.
5. An illegal digit was encountered in a decimal numeric operand.
6. An illegal specification was found in an EIS operand descriptor.

The conditions for the fault will be set in the fault register, word 1 of the Control Unit Data, or in both.

Group 6 Faults

Directed Faults 0-3

A faulted segment descriptor word (SDW) or page table word (PTW) with the corresponding directed fault number has been fetched by the appending unit.

Access Violation

The appending unit has detected one of the several access violations below. Word 1 of the Control Unit Data contains status bits for the condition.

1. Not in read bracket (ACV3=ORB)
2. Not in write bracket (ACV5=OWB)
3. Not in execute bracket (ACV1=OEB)
4. No read permission (ACV4=R-OFF)

5. No write permission (ACV6=W-OFF)
6. No execute permission (ACV2=E-OFF)
7. Invalid ring crossing (ACV12=CRT)
8. Call limiter fault (ACV7=NO GA)
9. Outward call (ACV9=OCALL)
10. Bad outward call (ACV10=BOC)
11. Inward return (ACV11=INRET)
12. Ring alarm (ACV13=RALR)
13. Associative memory error
14. Out of segment bounds (ACV15=OOSB)
15. Illegal ring order (ACV0=IRO)
16. Out of call brackets (ACV8=OCB)

Group 7 Faults

Shutdown

An external power shutdown condition has been detected. DC POWER shutdown will occur in approximately one millisecond.

Timer Runout

The timer register has decremented to or through the value zero. If the processor is in privileged mode or absolute mode, recognition of this fault is delayed until a return to normal mode or BAR mode. Counting in the timer register continues.

Connect

A connect signal (\$CON strobe) has been received from a system controller. This event is to be distinguished from a Connect Input/Output Channel (cioc) instruction encountered in the program sequence.

(See the discussion of the floating faults in Section 3).

INTERRUPTS AND EXTERNAL FAULTS

Each system controller contains 32 interrupt cells that are used for communication among the active system modules (processors, I/O multiplexers, etc.). The interrupt cells are organized in a numbered priority chain. Any active system module connected to a system controller port may request the setting of an interrupt cell with the SXC system controller command.

When one or more interrupt cells in a system controller is set, the system controller activates the interrupt present (XIP) line to all system controller ports having an assigned interrupt mask in which one or more of the interrupt cells that are set is unmasked. Interrupt masks should be assigned only to processors. Each interrupt cell has associated with it a unique interrupt trap pair located at an absolute main memory address equal to twice the cell number.

Interrupt Sampling

The processor always fetches instructions in pairs. At an appropriate point (as early as possible) in the execution of a pair of instructions, the next sequential instruction pair is fetched and held in a special instruction

buffer register. The exact point depends on instruction sequence and other conditions.

If the interrupt inhibit bit (bit 28) is not set in the current instruction word at the point of next sequential instruction pair virtual address formation, the processor samples the group 7 faults. If any of the group 7 faults is found an internal flag is set reflecting the presence of the fault. The processor next samples the interrupt present lines from all eight memory interface ports and loads a register with bits corresponding to the states of the lines. If any bit in the register is set ON an internal flag is set to reflect the presence of the bit(s) in the register.

If the instruction pair virtual address being formed is the result of a transfer of control condition or if the current instruction is Execute (xec), Execute Double (xed), Repeat (rpt), Repeat Double (rpd), or Repeat Link (rpl), the group 7 faults and interrupt present lines are not sampled.

At an appropriate point in the execution of the current instruction pair, the processor fetches the next instruction pair. At this point, it first tests the internal flags for group 7 faults and interrupts. If either flag is set does not fetch the next instruction pair.

At the completion of the current instruction pair the processor once again checks the internal flags. If neither flag is set, execution of the next instruction pair proceeds. If the internal flag for group 7 faults is set, the processor enters a FAULT CYCLE for the highest priority group 7 fault present. If the internal flag for interrupts is set, the processor enters an INTERRUPT CYCLE.

Interrupt Cycle Sequence

In the INTERRUPT CYCLE, the processor safe-stores the Control Unit Data (see Section 3) into program-invisible holding registers in preparation for a Store Control Unit (scu) instruction, enters temporary absolute mode, and forces the current ring of execution C(PPR.PRR) to 0. It then issues an XEC system controller command to the system controller on the highest priority port for which there is a bit set in the interrupt present register.

The selected system controller responds by clearing its highest priority interrupt cell and returning the interrupt trap pair address for that cell to the processor.

If there is no interrupt cell set in the selected system controller (implying that all have been cleared in response to XEC system controller commands from other processors), the system controller returns the address value 1, which is not a valid interrupt trap pair address. The processor senses this value, aborts the INTERRUPT CYCLE, and returns to normal sequential instruction processing.

The interrupt trap pair address returned and the operation code for the Execute Double (xed) instruction are forced into the instruction register and executed as an instruction. Note that the execution of the instruction is not done in a normal EXECUTE CYCLE but in the INTERRUPT CYCLE with the processor in temporary absolute mode.

If the attempt to fetch and execute the instruction pair at the interrupt trap pair results in a fault, the INTERRUPT CYCLE is aborted and a FAULT CYCLE for the trouble fault (fault number 31) is initiated. In the FAULT CYCLE for a

trouble fault, the processor does not safe-store the Control Unit Data. Therefore, it may be possible to recover the conditions for the interrupt (except the interrupt number) by use of the Store Control Unit (scu) instruction. The interrupt number may usually be recovered by analysis of the computed address for the interrupt trap pair stored in the control unit history registers.

If either of the two instructions in the interrupt trap pair results in a transfer of control to a computed address generated in absolute mode, the absolute mode indicator is set ON for the transfer and remains ON thereafter until changed by program action.

If either of the two instructions in the interrupt trap pair results in a transfer of control to a computed address generated in append mode (through the use of bit 29 of the instruction word or by use of the itp or its modifiers), the transfer is made in the append mode and the processor remains in append mode thereafter.

If no transfer of control takes place, the processor returns to the mode in effect at the time of the interrupt and resumes normal sequential execution with the instruction following the interrupted instruction ($C(PPR.IC) + 1$). Note that the current ring of execution $C(PPR.PRR)$ was forced to 0 during the INTERRUPT CYCLE and that normal sequential execution will resume in ring 0.

Due to the time required for many of the EIS data movement instructions, additional group 7 fault and interrupt sampling is done during these instructions. After the initial load of the decimal unit input data buffer, group 7 faults and interrupts are sampled for each input operand virtual address formation. The instruction in execution is interrupted before the operand is fetched and flags are set into Control Unit Data and Decimal Unit Data to allow the restart of the instruction.

NOTE: The execution of a Store Pointers and Lengths (spl) instruction is required before an interrupted EIS instruction may be restarted. Therefore, a fault or interrupt handling routine must execute this instruction even though it does not use the decimal unit for its processing.

Many of the interrupts are deliberately or inadvertently caused by the software and do not necessarily involve error conditions. The operating supervisor determines the proper action for each interrupt by analyzing the detailed state of the processor at the time of the interrupt. In order to accomplish this analysis, it is necessary that the first instruction in each of the interrupt trap pairs be the Store Control Unit (scu) instruction and the second be a transfer to an interrupt analysis routine. If an interrupt is to be intentionally ignored, the trap pair for that interrupt should contain an scu/rcu pair referencing a unique Y-block8. By using this pair to ignore an interrupt, the state of the processor for the ignored interrupt may be recovered if the ignored interrupt causes a trouble fault. The use of the scu/rcu pair also ensures that execution is resumed in the original ring of execution.

SECTION 8

HARDWARE RING IMPLEMENTATION

The philosophy of ring protection is based on the existence of a set of hierarchical levels of protection. This concept can be illustrated by a set of N concentric circles, numbered 0, 1, 2, ..., $N-1$ from the inside out. The space included in circle 0 is called ring 0, the space included between circle $i-1$ and i is called ring i . Any segment in the system is placed in one and only one ring. The closer a segment to the center, the greater its protection and privilege.

When a program is executing a procedure segment placed in ring R , the program is said to be in ring R , or that the ring of execution or current ring is ring R . A program in ring R potentially has access to any segment located in ring R and in outer rings. The word "potentially" is used because the final decision is subject to what access rights the user has for the target segment. This same program in ring R has no access to any segment located in inner rings, except to special procedures called gates.

Gates are procedures residing in a given ring and intended to provide controlled access to the ring. A program that is in ring R can enter an inner ring r only by calling one of the gate procedures associated with this inner ring r . Gates must be carefully coded and must not trust any data that has been manufactured or modified by the caller in a less privileged ring. In particular, gates must validate all arguments passed to them by the caller so as not to compromise the protection of any segment residing in the inner ring.

Calls from an outer ring to an inner ring are referred to as inward calls. They are associated with an increase in the access capability of the program and are controlled by gates. Calls from an inner ring to an outer ring, referred to as outward calls are associated with a decrease in the access capability of the program and do not need to be controlled.

RING PROTECTION IN MULTICS

The ring protection designed for Multics uses the foregoing philosophy, extended to obtain more flexibility and better efficiency.

First, the assignment of a segment to one and only one ring is inconvenient for a class of procedure segments, such as library routines. Such procedures operate in whatever the ring of execution the program is at the time they are called; they need no more access than the caller. One solution could have been to have a copy of the library in each ring. Instead, the solution adopted by Multics is to relax the condition that a segment can be assigned to only one ring and allow a procedure segment to be assigned to a set of consecutive rings defined by two integers (r_1, r_2), with $r_1 \leq r_2$. If such a segment is called from ring R such that $r_1 \leq R \leq r_2$, it behaves as if it were in ring R , and executes without changing the current ring of the program. If it is called from ring R such that $R > r_2$, it behaves like a gate associated with ring r_2 , accepting the call as an inward call and decreasing the current ring of the program from R to r_2 . Upon return to the caller, the current ring is restored to R .

Second, the maximum ring number from which a gate can be called may be specified. A third integer, r_3 , is added to the pair of integers already associated with a segment. Any procedure segment has associated with it three ring numbers (r_1, r_2, r_3), called its ring brackets, such that $r_1 \leq r_2 \leq r_3$. If $r_3 > r_2$, the procedure is a gate for ring r_2 , accessible from rings no higher than r_3 ; if $r_2 = r_3$, the procedure is not a gate. Because outward calls are declared illegal in Multics, a segment may be called from a ring R only if $r_1 \leq R \leq r_3$. Such a segment is said to have the call bracket $[r_1, r_3]$.

Third, data segments may also be used in more than one ring. A segment resides in ring r_1 for write purposes but resides in a less privileged ring r_2 for read purposes. Such a segment is said to have the write bracket $[0, r_1]$ and the read bracket $[0, r_2]$.

In summary, the operations that are potentially permitted to a program in ring R on a segment whose ring brackets are (r_1, r_2, r_3) are as follows:

```
Write      : if  $0 \leq R \leq r_1$ 
Read       : if  $0 \leq R \leq r_2$ 
Execute    : if  $r_1 \leq R \leq r_2$  (execution in ring  $R$ )
Inward call: if  $r_2 < R \leq r_3$  (execution in ring  $r_2$ )
```

RING PROTECTION IN THE PROCESSOR

The processor provides hardware support for the implementation of Multics ring protection. A particular effort was made to minimize the overhead associated with all authorized ring crossings, which the processor performs without operating system intervention; and also to minimize the overhead associated with the validation of arguments, for which the processor provides assistance.

The number of rings available in the processor is eight, numbered from 0 to 7. The current ring R of a program is recorded in the procedure ring register (PPR.PRR).

The ring brackets (r_1, r_2, r_3) of a segment are recorded in the segment descriptor word (SDW) used by the hardware to access the segment. In addition, the SDW contains the number of legal gate entries (SDW.CL) existing in the segment. The hardware assumes that all gate entries are located from word 0 to word (CL-1) and does not permit an inward call to the segment if the word number specified in the call is greater than (CL-1). The SDW also contains the access rights for the user on the segment. If the same segment is used by several users, who may have different access rights to the segment, there is an SDW describing the segment in the descriptor segment for each user.

In order to provide assistance in argument validation, any pointer being stored into an its pointer pair or loaded into a pointer register also contains a ring number. A program in ring R may write any value into the ring number field of an its pointer pair; the hardware assures that, when a pointer register is loaded from an its pointer pair, the ring number loaded is equal to or greater than R, but never smaller.

During the execution of an instruction, the hardware may examine several SDWs, its pointer pairs and pointer registers. For any given examination, the hardware records the maximum of the current ring, the r1 value found in an SDW, the ring number found in an its pointer pair, and the ring number found in a pointer register. This maximum is kept in the temporary ring register (TPR.TRR) and is updated at each such examination. The reason for having this temporary ring number available at any point of instruction execution is that it represents the highest ring (least privileged) that might have created or modified any information that led the hardware to the target segment it is about to reference. Although the current ring is R, the hardware evaluates references as if the current ring were C(TPR.TRR), which is always equal to or greater than R. The hardware uses C(TPR.TRR) instead of R in all comparisons with the ring brackets involved in the enforcement of the ring protection rules given in the previous paragraph.

The use of C(TPR.TRR) by the hardware allows gate procedures to rely on the hardware to perform the validation of all addresses passed to the gate by the less privileged ring. The rule enforced by the hardware regarding argument validation can be stated as follows:

Whenever an inner ring performs an operation on a given segment and references that segment through pointers manufactured by an outer ring, the operation is considered valid only if it could have been performed while in the outer ring.

APPENDING UNIT OPERATION WITH RING MECHANISM

The complete flow chart for effective segment number generation, including the hardware ring mechanism, is shown in Figure 8-1 below. See the description of the access violation fault in Section 7 for the meanings of the coded faults. The current instruction is in the instruction working buffer (IWB).

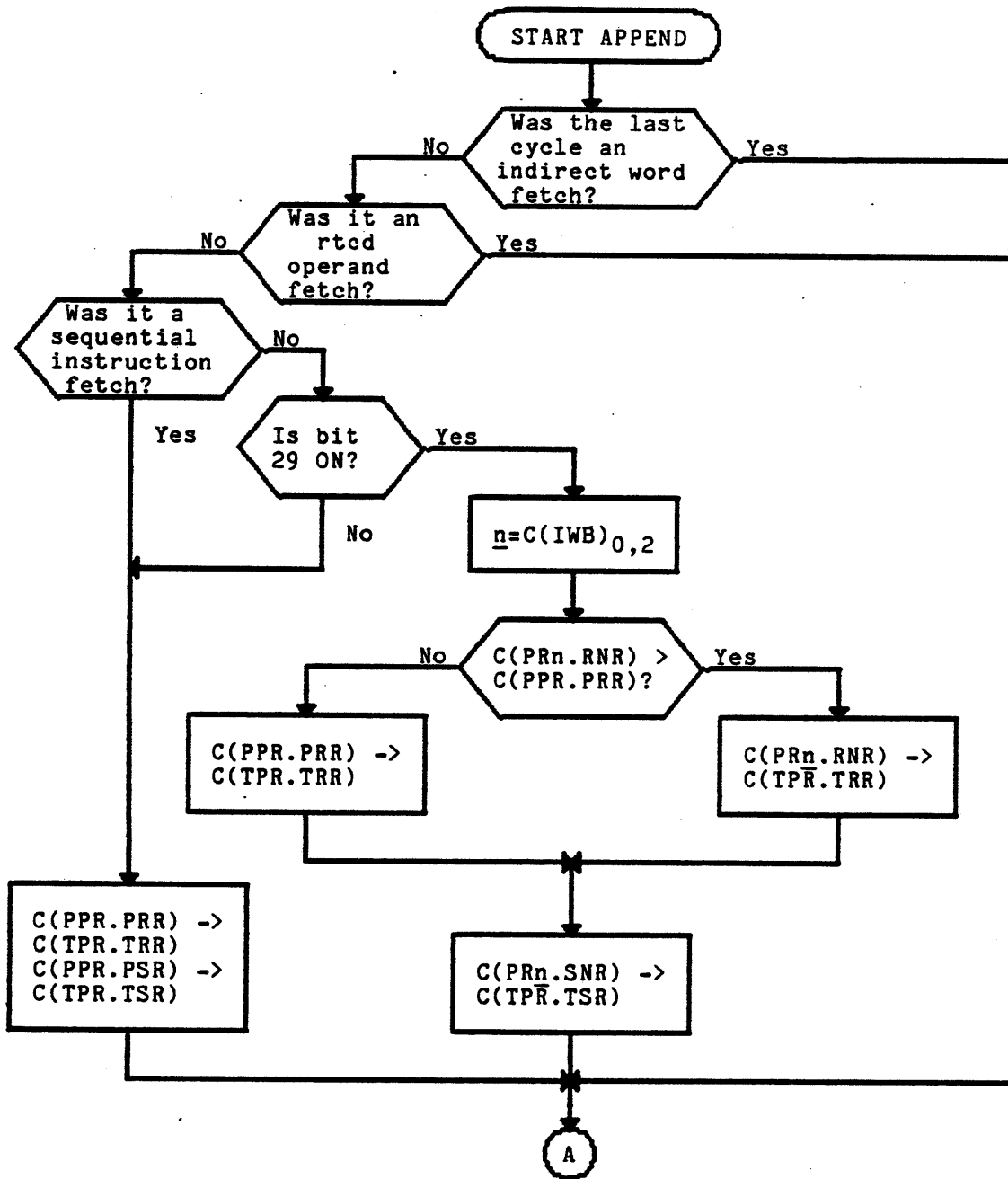

Figure 8-1. Complete Appending Unit Operation Flowchart

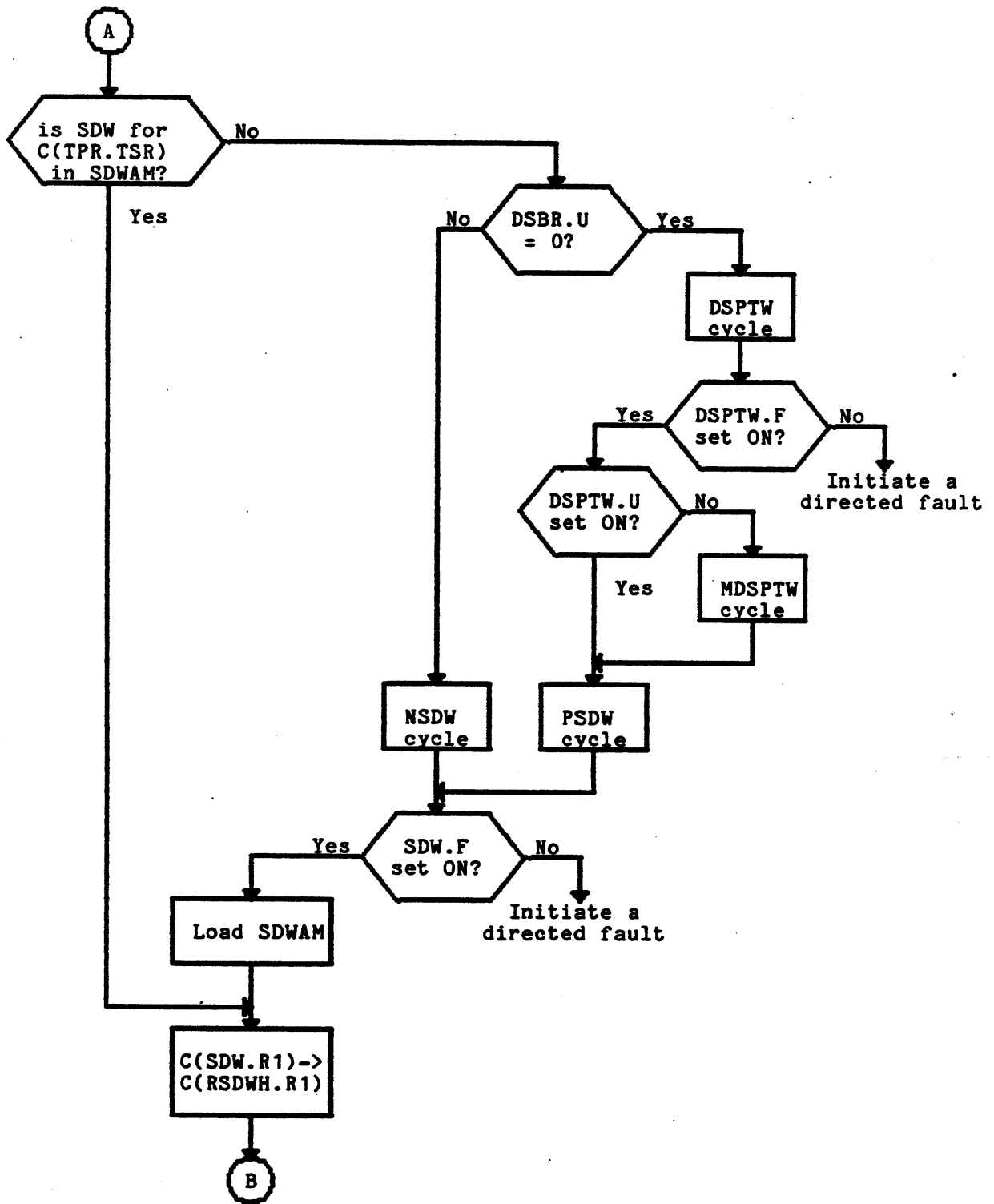

Figure 8-1(cont). Complete Appending Unit Operation Flowchart

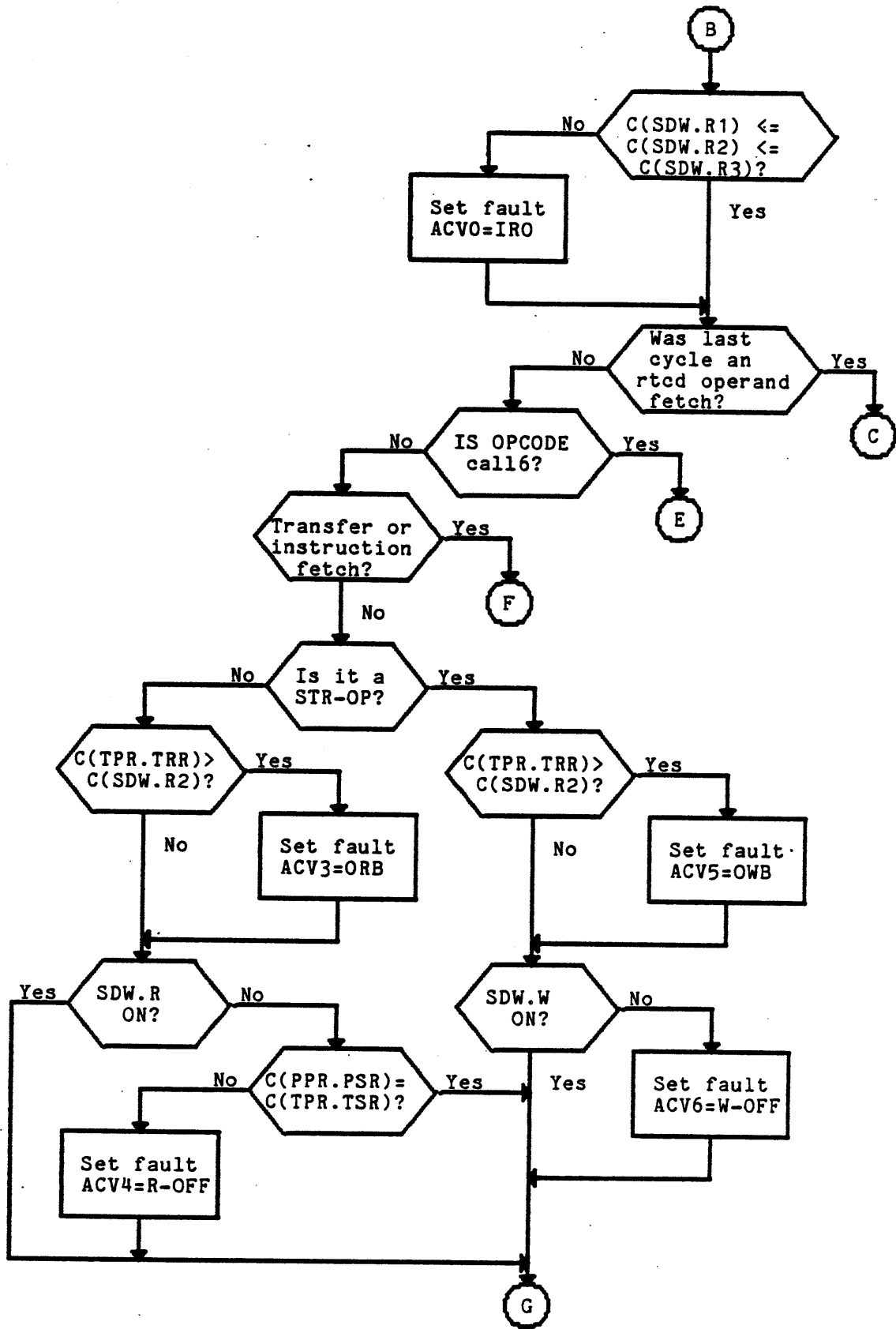

Figure 8-1(cont). Complete Appending Unit Operation Flowchart

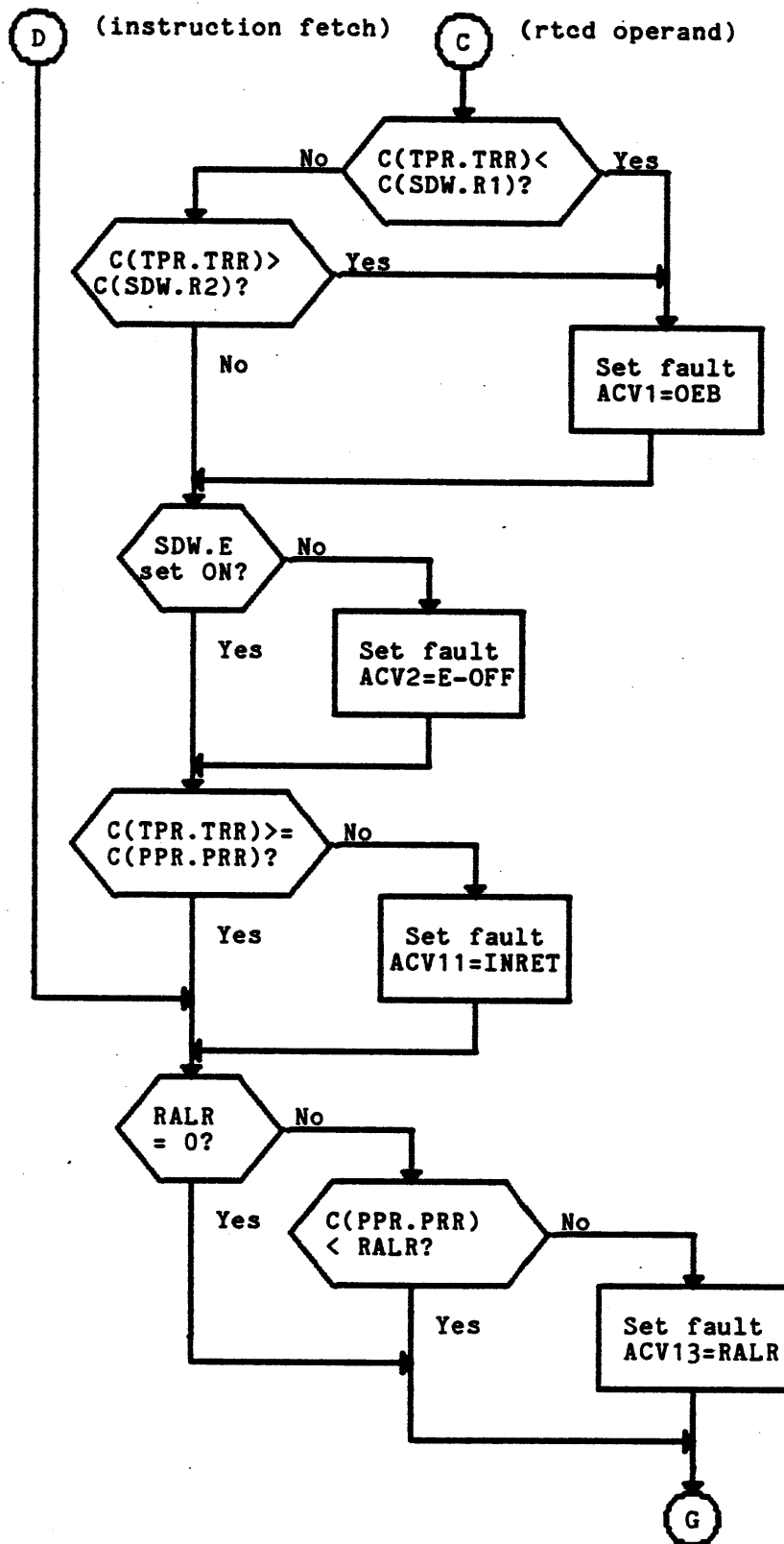

Figure 8-1(cont). Complete Appending Unit Operation Flowchart

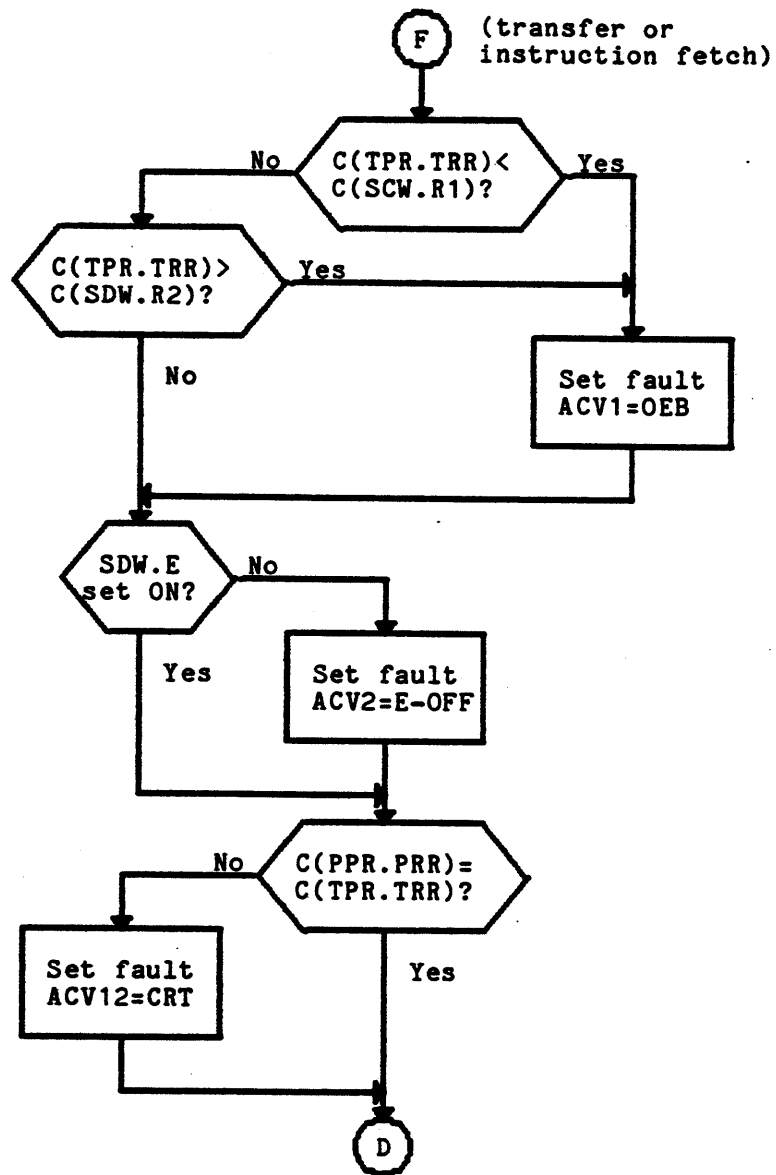

Figure 8-1(cont). Complete Appending Unit Operation Flowchart

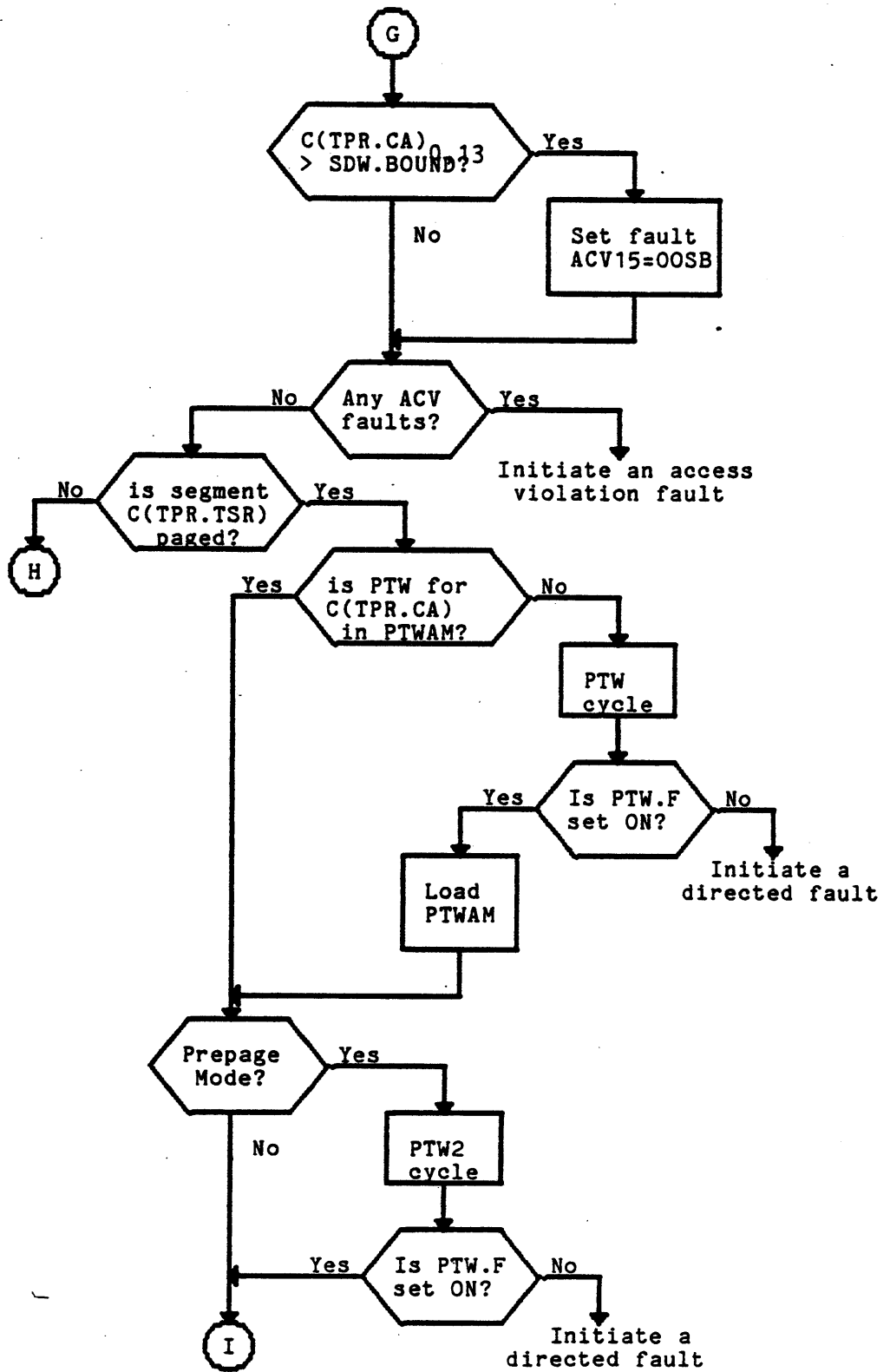

Figure 8-1(cont). Complete Appending Unit Operation Flowchart

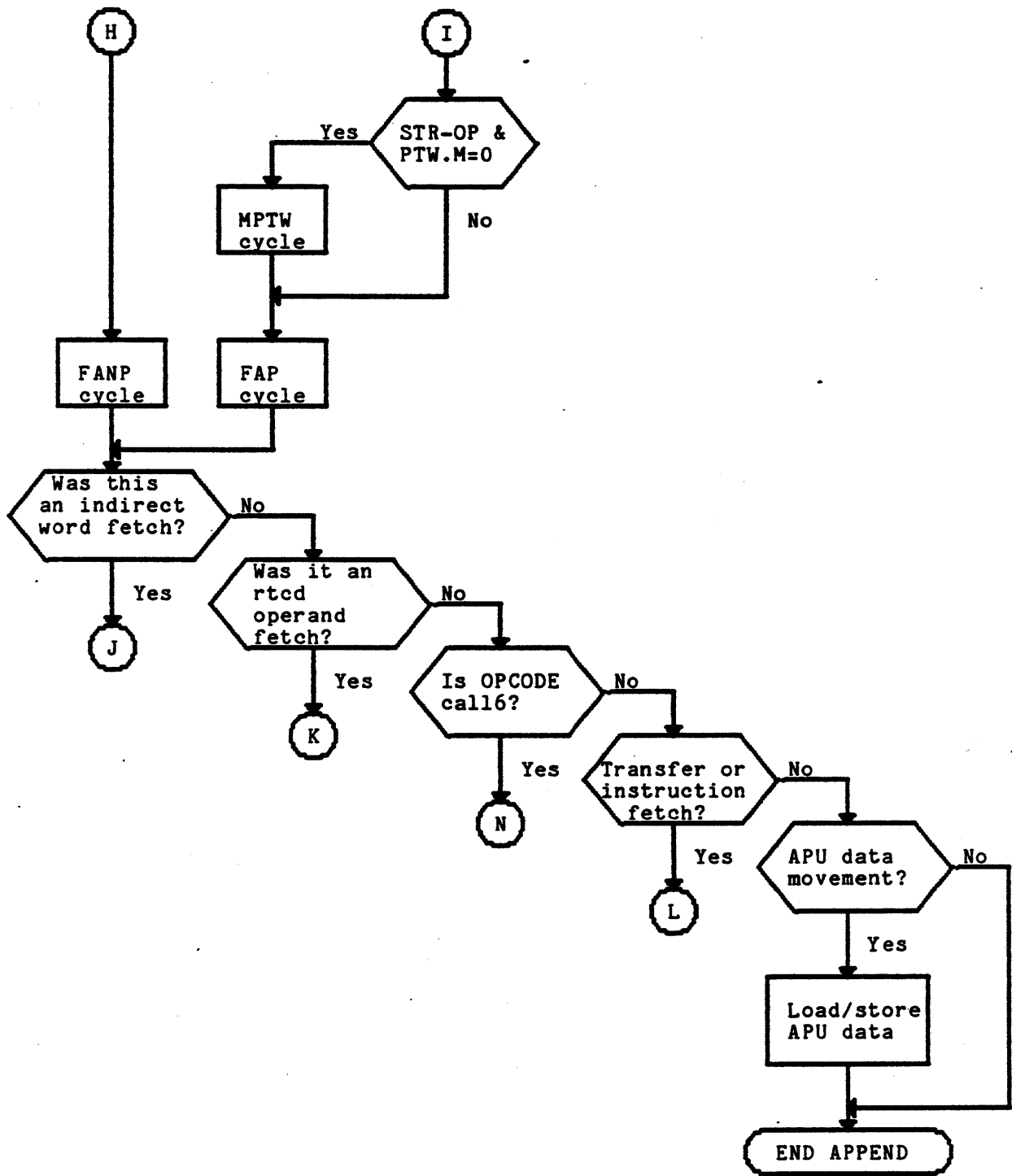

Figure 8-1(cont). Complete Appending Unit Operation Flowchart

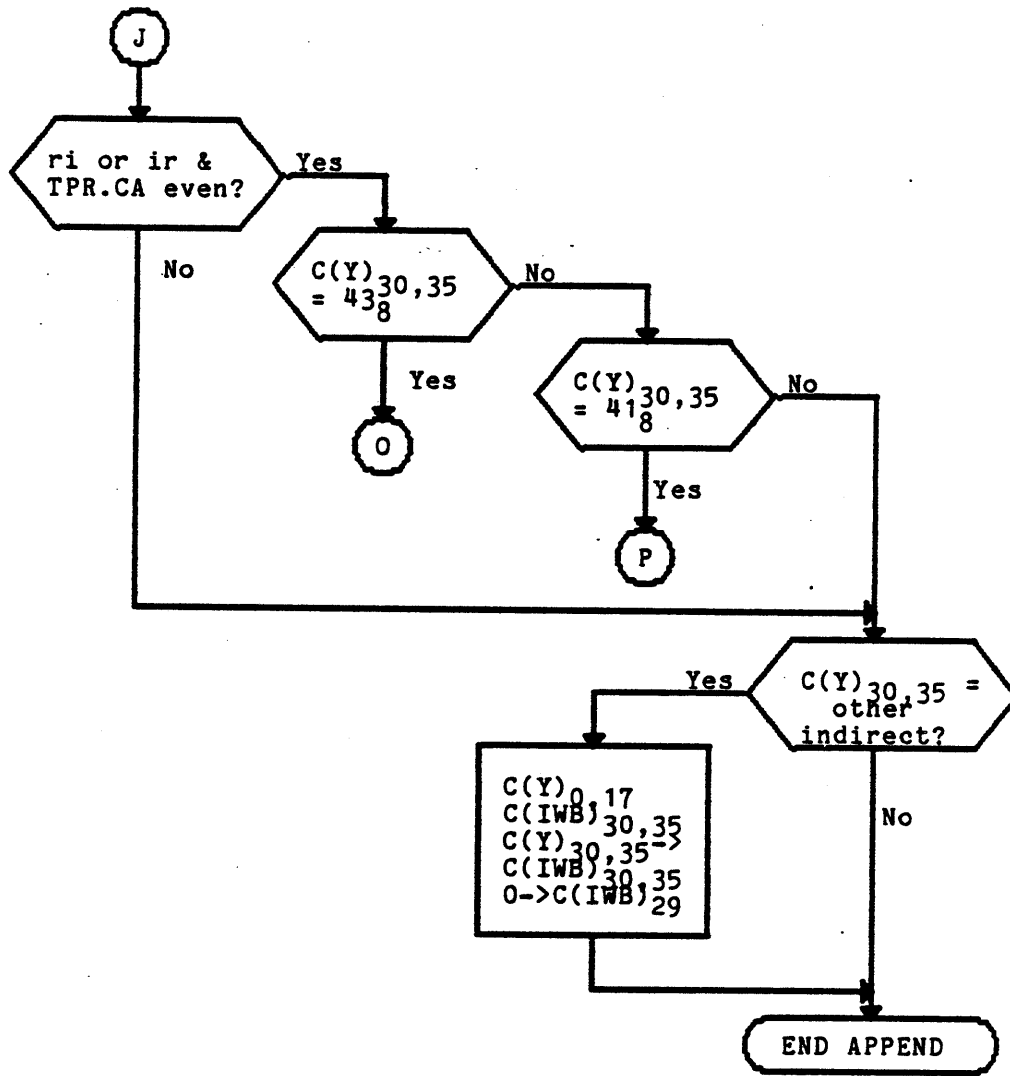

Figure 8-1(cont). Complete Appending Unit Operation Flowchart

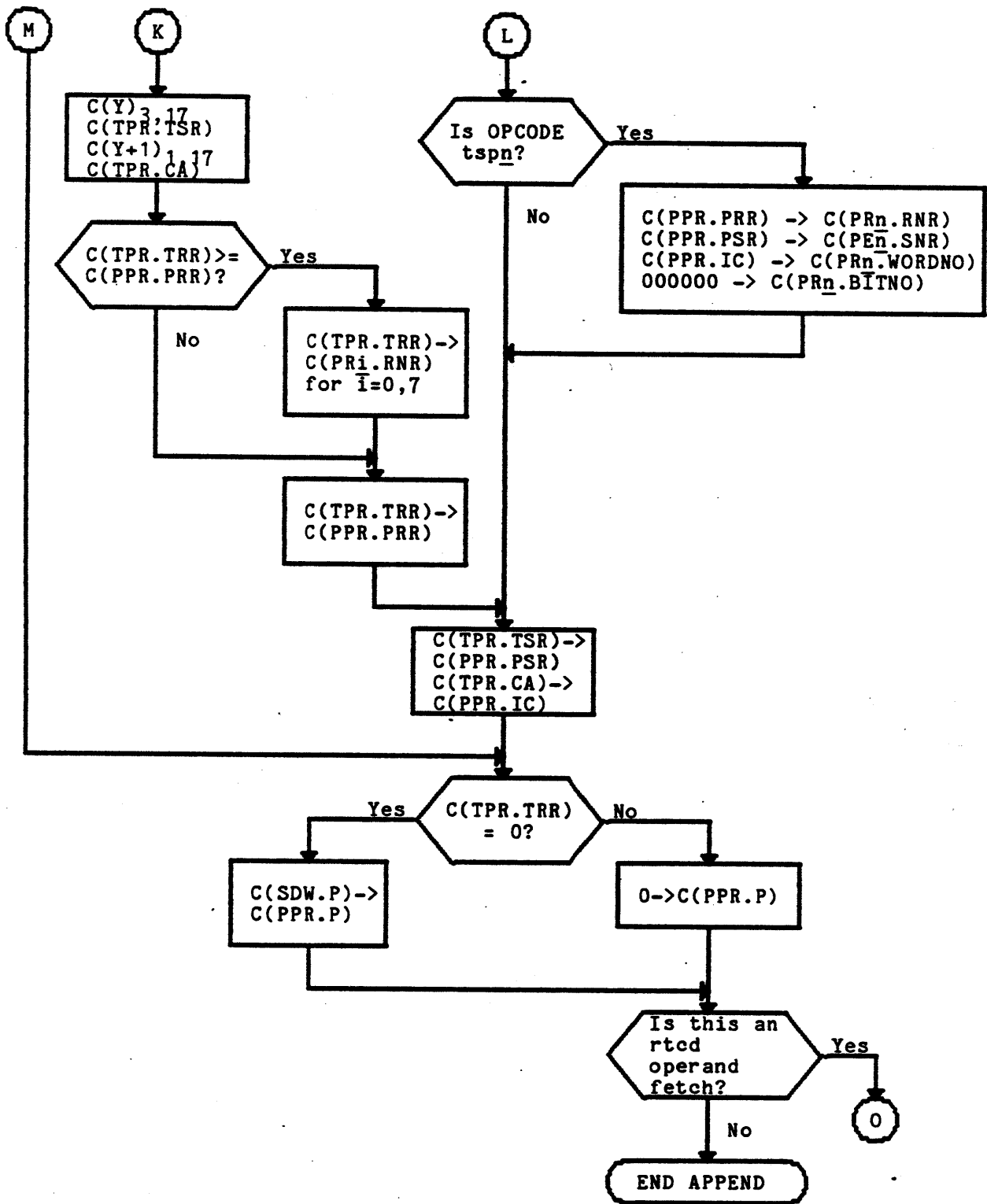

Figure 8-1(cont). Complete Appending Unit Operation Flowchart

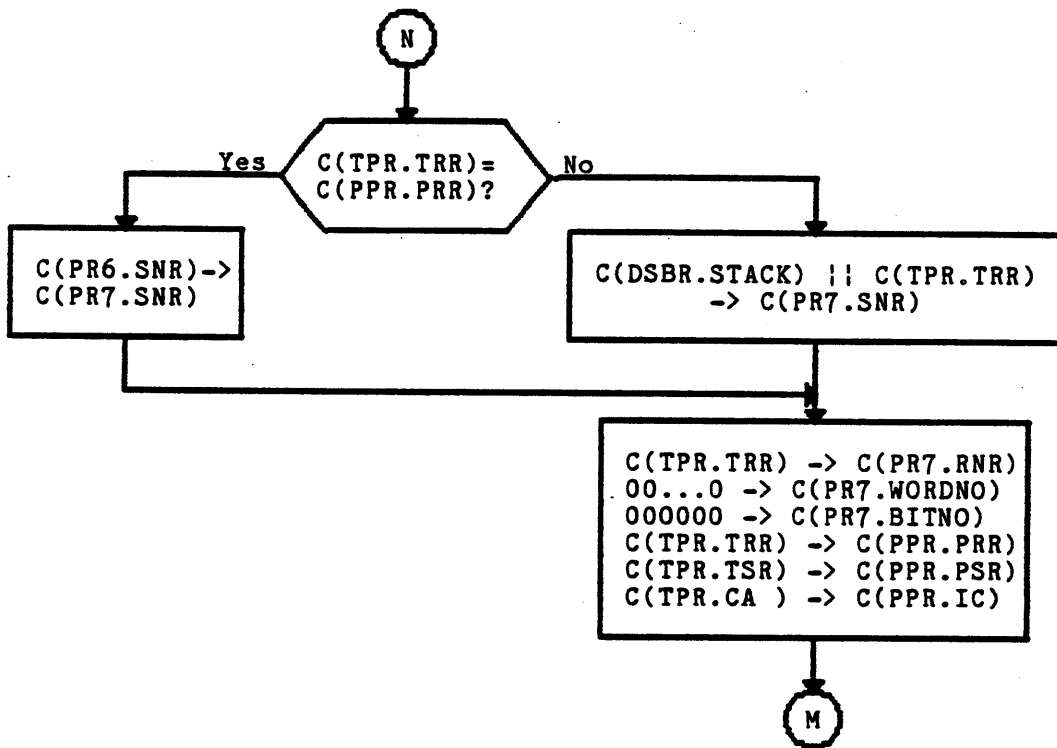

Figure 8-1(cont). Complete Appending Unit Operation Flowchart

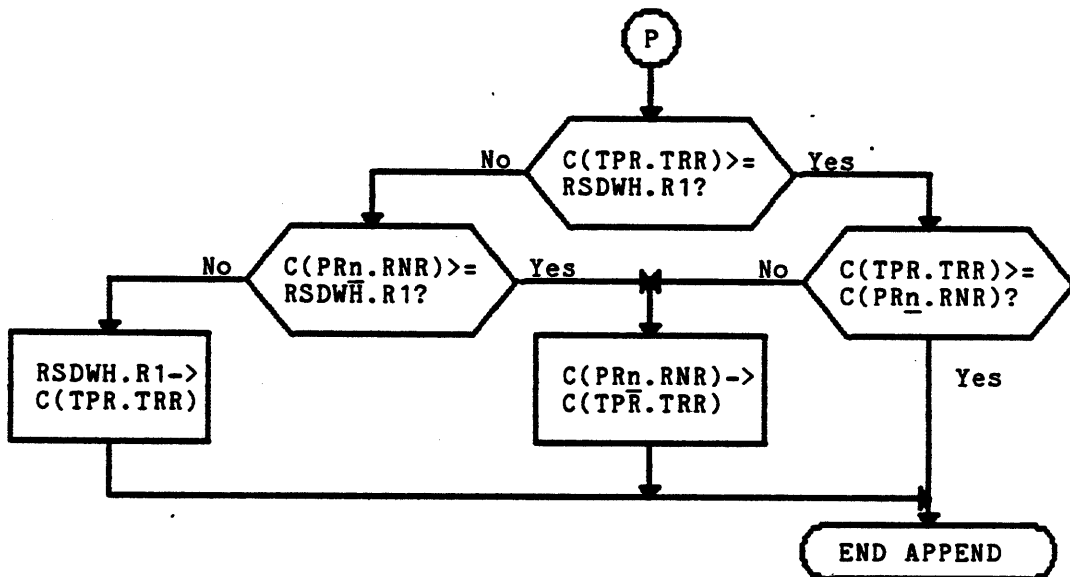
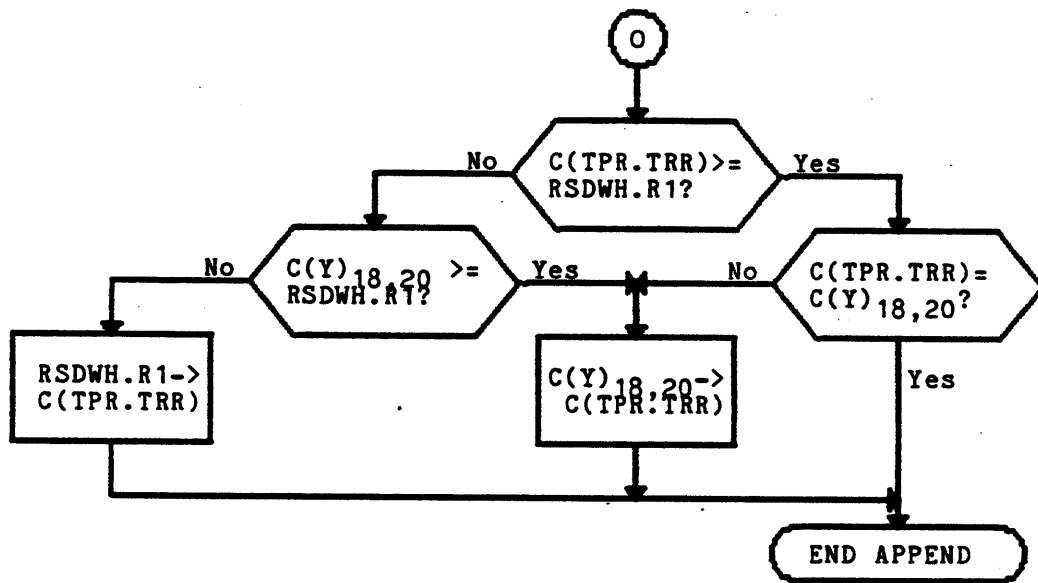

Figure 8-1(cont). Complete Appending Unit Operation Flowchart

SECTION 9

CACHE MEMORY OPERATION

The Multics processor may be fitted with an optional cache memory. The operation of this cache memory is described in this section.

PHILOSOPHY OF CACHE MEMORY

The cache memory is a high speed buffer memory located within the processor that is intended to hold operands and/or instructions in expectation of their immediate use. This concept is different from that of holding a single operand (such as the divisor for a divide instruction) in the processor during execution of a single instruction. A cache memory depends on the locality of reference principle. Locality of reference involves the calculation of the probability, for any value of d , that the next instruction or operand reference after a reference to the instruction or operand at location A is to location $A+d$.

The calculation of probabilities for a set of values of d requires the statistical analysis of large volumes of real and simulated instruction sequences and data organizations. If it can be shown that the average expected data/instruction access time reduction (over the range 1 to d) is statistically significant in comparison to the fixed main memory access time, then the implementation of a cache memory with block size d will contribute a significant improvement in performance.

The results of such studies for the Multics processor with a cache memory as described below (with $d = 4$) show a hit probability ranging between 80 and 95 percent (depending on instruction mix and data organization) and a performance improvement ranging up to 30 percent.

CACHE MEMORY ORGANIZATION

The cache memory is implemented as 2048 36-bit words of high-speed register storage with associated control and content directory circuitry within the processor. It is fully integrated with the normal data path circuitry and is virtually invisible to all programming sequences. Parity is generated, stored, and/or checked on each data reference. The total storage is divided into 512 blocks of 4 words each and the blocks are organized into 128 columns of four levels each.

Cache Memory/Main Memory Mapping

Main memory is mapped into the cache memory as described below and shown in Figure 9-1.

Main memory is divided into N blocks of 4 words each arranged in ascending order and numbered with the value of $Y_{15,21}$ of the first word of the block.

All main memory blocks with numbers n modulo 128 are grouped associatively with cache memory column n .

Each cache memory column may hold any four blocks of the associated set of main memory blocks.

Each cache memory column has associated with it a four entry directory (one entry for each level) and a 2-bit round robin counter. Parity is generated, stored, and checked on each directory entry.

A cache directory entry consists of a 15-bit ADDRESS register, a pre-set, 2-bit level number value and a level full flag bit.

When a main memory block is loaded into a cache memory block at some level in the associated column, the directory ADDRESS register for that column and level is loaded with $Y_{0,14}$. (Level selection is discussed in "Cache Memory Control" later in this section.)

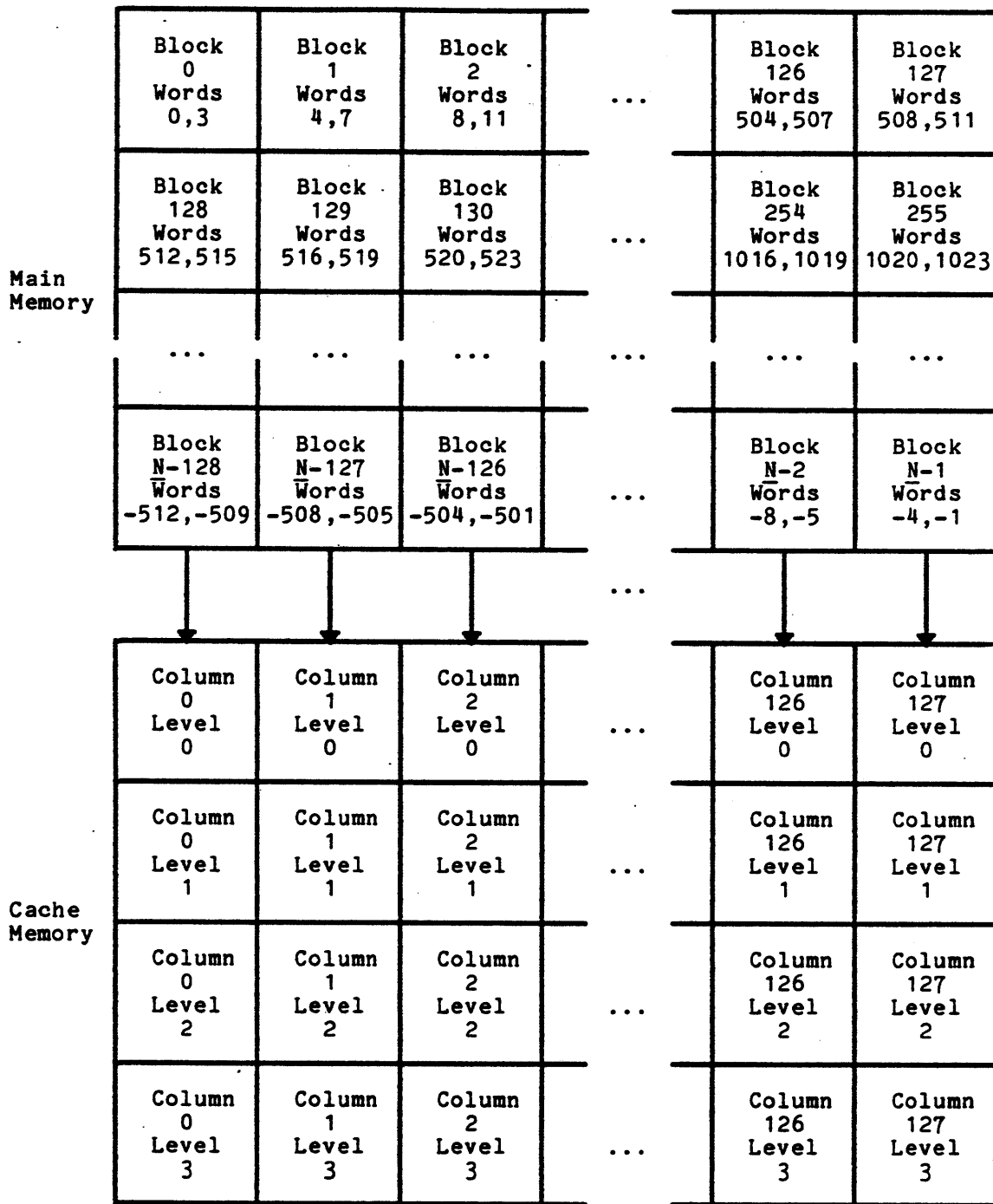

Figure 9-1. Main Memory/Cache Memory Mapping

Cache Memory Addressing

For a read operation, the 24-bit absolute main memory address prepared by the appending unit is presented simultaneously to the cache control and to the main memory port selection circuitry. While port selection is being accomplished, the cache memory is accessed as follows.

$Y_{15,21}$ are used to select a cache memory column.

$Y_{0,14}$ are matched associatively against the four directory ADDRESS registers for the selected column.

If a match occurs for a level whose full flag is ON, a hit is signaled, the main memory reference cycle is cancelled, and the level number value is read out.

The level number value and $Y_{22,23}$ are used to select the level and word in the selected column and the cache memory data is read out into the data circuitry.

If no hit is signaled, the main memory reference cycle proceeds and a cache memory block load cycle is initiated (see "Cache Memory Control" below).

For a write operation, the 24-bit absolute main memory address prepared by the appending unit is presented simultaneously to the cache control and to the main memory port selection circuitry. While port selection is being accomplished, the cache memory is accessed as follows.

$Y_{15,21}$ are used to select a cache memory column.

$Y_{0,14}$ are matched associatively against the four directory ADDRESS registers for the selected column.

If a match occurs for a level whose full flag is ON, a hit is signaled and the level number value is read out.

The level number value and $Y_{22,23}$ are used to select the level and word in the selected column, a cache memory write cycle is enabled, and the data is written to the main memory and the cache memory simultaneously.

If no hit is signaled, the main memory reference cycle proceeds with no further cache memory action.

CACHE MEMORY CONTROL

Enabling and Disabling Cache Memory

The cache memory is controlled by the state of several bits in the cache mode register (see Section 3). The cache mode register may be loaded with the Load Central Processor Register (lcpr) instruction. The cache memory control bits are as follows:

<u>bit</u>	<u>Value</u>	<u>Action</u>
54	0	The lower half of the cache memory (levels 0 and 1) is disabled.
	1	The lower half of the cache memory is active and enabled as per the state of bits 56-57.
55	0	The upper half of the cache memory (levels 2 and 3) is disabled.
	1	The upper half of the cache memory is active and enabled as per the state of bits 56-57.
56	0	The cache memory (if active) <u>is not</u> used for operands and indirect words.
	1	The cache memory (if active) <u>is</u> used for operands and indirect words.
57	0	The cache memory (if active) <u>is not</u> used for instructions.
	1	The cache memory (if active) <u>is</u> used for instructions.
59	0	The cache-to-register mode <u>is not</u> in effect (see "Dumping the Cache Memory" later in this section).
	1	The cache-to-register mode <u>is</u> in effect.

NOTE: The cache memory option furnishes a switch panel maintenance aid that attaches to the free edge of the cache memory control logic board. The switch panel provides six switches for manual control of the cache memory:

Four of the switches inhibit the control functions of bits 54-57 of the cache mode register and have the effect of forcing the corresponding function to be disabled.

The fifth switch inhibits the store-aside feature wherein the processor is permitted to proceed immediately after the cache memory write cycle on write operations without waiting for a data acknowledgement from main memory. (There is no software control corresponding to this switch).

The sixth switch forces the enabled condition on all cache memory controls (except cache-to-register mode) without regard to the corresponding cache mode register control bit.

There is no switch corresponding to the cache-to-register control bit.

While these switches are intended primarily for maintenance sessions, they have been found useful in testing the cache memory during normal operation and in permitting operation of the processor with the cache memory in degraded or partially disabled mode.

Cache Memory Control in Segment Descriptor Words

Certain data have characteristics such that they should never be loaded into the cache memory. Primary examples of such data are hardware mailboxes for the I/O multiplexer, bulk store controller, etc., status return words, and various dynamic operating system data base segments. In general, any data that is modified by an agency external to a processor with the intent to convey information to that processor should never be loaded into cache memory.

Bit 57 of the segment descriptor word is used to reflect this property of "encacheability" for each segment. (See Section 5 for a discussion of the segment descriptor word.) If the bit is set ON, data from the segment may be loaded into the cache memory; if the bit is OFF, they may not. The operating system may set bit 57 ON or OFF as appropriate for the use of the segment.

Loading the Cache Memory

The cache memory is loaded with data implicitly whenever a cache memory block load is required. (See the discussion of read operations in "Cache Memory Addressing" earlier in this section.) There is no explicit method or instruction to load data into the cache memory.

When a cache memory block load is required, the level is selected from the value of the round robin counter for the selected column, and the cache memory write function is enabled. (The round robin counter contains the number of the least recently loaded level.) When the data arrives from main memory, it is written into the cache memory and entered into the data circuitry. The processor proceeds with the execution of the instruction requiring the operand if appropriate.

When the cache memory write is complete, further virtual address formation is inhibited, Y_{22} is inverted, and a second main memory access for the other half of the block is made. When the second half data arrives from main memory, it is written into the cache memory, $Y_{0,14}$ are loaded into the directory ADDRESS register, the level full flag is set ON, the round robin counter is advanced by 1, and virtual address formation is permitted to proceed.

If all four level full flags for a column are set ON, a column full flag is also set ON and remains ON until one or more levels in the column are cleared.

Clearing the Cache Memory

Cache memory can be cleared in two ways; general clear and selective clear. The clearing action is the same in both cases, namely, the full flags of the selected column(s) and/or level(s) are set OFF.

GENERAL CLEAR

The entire cache memory is cleared by setting all column and level full flags to OFF in the following situations:

Upper or lower cache memory or both becoming enabled by appropriate bits in the operand of the Load Central Processor Register (lcp_r)

instruction or by action of the cache memory control logic board free edge switches.

Execution of a Clear Associative Memory Segments (cams) instruction with bit 15 of the address field set ON.

SELECTIVE CLEAR

The cache memory is cleared selectively as follows:

If a read-and-clear operation (ldac, sznc, etc.) results in a hit on the cache memory, that cache memory block hit is cleared.

Execution of a Clear Associative Memory Pages (camp) instruction with address bit 15 set ON causes $Y_{13,14}$ to be matched against all cache directory ADDRESS registers. All cache memory blocks hit are cleared.

Dumping the Cache Memory

When the cache-to-register mode flag (bit 59 of the cache mode register) is set ON, the processor is forced to fetch the operands of all double-precision operations unit load operations from the cache memory. $Y_{0,12}$ are ignored, $Y_{15,21}$ select a column, and $Y_{13,14}$ select a level. All other operations (e.g., instruction fetches, single-precision operands, etc.) are treated normally.

Note that the phrase "treated normally" as used here includes the case where the cache memory is enabled. If the cache memory is enabled, the "other" operations causes normal block loads and cache memory writes thus destroying the original contents of the cache memory. The cache memory should be disabled before dumping is attempted.

An indexed program loop involving the ldaq and staq instructions with the cache-to-register mode bit set ON serves to dump any or all of the cache memory.

The occurrence of a fault or interrupt sets the cache-to-register mode bit to OFF.

APPENDIX A

OPERATION CODE MAP

This appendix contains the operation code map for the processor in Figure A-1. The second, or continued portion of the map (Figure A-1) includes extended instruction set (EIS) instructions. Figure A-2 identifies the differences noted between the EIS MF Codes described in this manual and the ALM keywords in the MPM Subsystem Writers' Guide, Order No. AK92. Also see Appendix B for an alphabetical instruction list.

OPERATION CODE MAP (BIT 27 = 0)

	000	001	002	003	004	005	006	007	010	011	012	013	014	015	016	017
000		mme	dr1		mme2	mme3		mme4		nop	puls1	puls2		cioc		
020	adlx0	adlx1	adlx2	adlx3	adlx4	adlx5	adlx6	adlx7			ldqc	adl	ldac	adla	adlq	adlaq
040	asx0	asx1	asx2	asx3	asx4	asx5	asx6	asx7	adwp0	adwp1	adwp2	adwp3	aos	asa	asq	sscr
060	adx0	adx1	adx2	adx3	adx4	adx5	adx6	adx7		awca	awcq	lreg		ada	adq	adaq
100	cmpx0	cmpx1	cmpx2	cmpx3	cmpx4	cmpx5	cmpx6	cmpx7								
120	sblx0	sblx1	sblx2	sblx3	sblx4	sblx5	sblx6	sblx7		cw1				cmpa	cmpq	cmpaq
140	ssx0	ssx1	ssx2	ssx3	ssx4	ssx5	ssx6	ssx7						sbla	sblq	sblaq
160	sbx0	sbx1	sbx2	sbx3	sbx4	sbx5	sbx6	sbx7	adwp4	adwp5	adwp6	adwp7	sdbr	ssa	ssq	ssaq
200	cnax0	cnax1	cnax2	cnax3	cnax4	cnax5	cnax6	cnax7		swca	swcq	lpri		sba	sbaq	sbaq
220	ldx0	ldx1	ldx2	ldx3	ldx4	ldx5	ldx6	ldx7		cmk	absa	epaq	sznc	cnaa	cnaq	cnaaq
240	orsx0	orsx1	orsx2	orsx3	orsx4	orsx5	orsx6	orsx7	lbar	rsw	ldbr	rmcm	szn	lda	ldq	ldaq
260	orx0	orx1	orx2	orx3	orx4	orx5	orx6	orx7	spri0	spbp1	spri2	spbp3	spri	orsa	orsq	lsdp
300	canx0	canx1	canx2	canx3	canx4	canx5	canx6	canx7	tsp0	tsp1	tsp2	tsp3		orc	erg	oraq
320	lcx0	lcx1	lcx2	lcx3	lcx4	lcx5	lcx6	lcx7	eawp0	easp0	eawp2	easp2		cana	canq	canaq
340	ansx0	ansx1	ansx2	ansx3	ansx4	ansx5	ansx6	ansx7	eawp4	easp4	eawp6	easp6		lca	lcq	lcaq
360	anx0	anx1	anx2	anx3	anx4	anx5	anx6	anx7	epp0	epbp1	epp2	epbp3	stac	ansa	ansq	stcd
400		mpf	mpy		cmg	fcmg		dfcmg	epp4	epbp5	epp6	epbp7		ana	anq	anaq
420		ufm		dufm	fxm			fszn	lde	fld	rscr	dfld		ade		
440	sxl0	sxl1	sxl2	sxl3	sxl4	sxl5	sxl6	sxl7	smic	frd	dfstr	dfstr	stt	ufa	ste	dufa
460		fmp		dfmp				fstr	frd	dfstr	dfstr	dfstr		fad		dfad
500	rpl				bcd	div	dvf					fneg		fcmp		dfcmp
520	rpt				fdi		dfdi		neg	stba	cams	neg1		ufs		dufs
540	sprp0	sprp1	sprp2	sprp3	sprp4	sprp5	sprp6	sprp7	sbar	stba	stbq	smcm	stc1			ssdp
560	rpd				fdv		dfd					fno		fsb		dfsb
600	tze	tnz	tnc	trc	tmi	tpl	ttf	rtcd				fno				
620	eax0	eax1	eax2	eax3	eax4	eax5	eax6	eax7	ret			rcu	teo	teu	dis	tov
640	ersx0	ersx1	ersx2	ersx3	ersx4	ersx5	ersx6	ersx7	spri4	spbp5	spri6	spbp7	ldi	eaa	eaq	ldt
660	erx0	erx1	erx2	erx3	erx4	erx5	erx6	erx7	spri4	tsp4	tsp5	tsp6	stacq	ersa	ersq	scu
700	tsx0	tsx1	tsx2	tsx3	tsx4	tsx5	tsx6	tsx7	tsp4	tsp5	tsp6	tsp7	lcpr	era	erq	eraq
720	lxl0	lxl1	lxl2	lxl3	lxl4	lxl5	lxl6	lxl7	tra			call6		tss	xec	xed
740	stx0	stx1	stx2	stx3	stx4	stx5	stx6	stx7		ars	qrs	lrs		als	qls	lls
760	lprp0	lprp1	lprp2	lprp3	lprp4	lprp5	lprp6	lprp7	stc2	stca	stcq	sreg	sti	sta	stq	staq
									arl	arl	arl	arl	gtb	alr	qlr	llr

Figure A-1. Processor Operation Code Map

OPERATION CODE MAP (BIT 27 = 1)

	000	001	002	003	004	005	006	007	010	011	012	013	014	015	016	017
020	mve				mvne											
040																
060	cs1	csr			sztl	sztr	cmpb									
100	mlr	mr1			scm	scmr	cmpc									
120	scd	scdr														
140																
160	mvt				tct	tctr						lpdr	sptr			
200			ad2d	sb2d			mp2d	dv2d								
220			ad3d	sb3d			mp3d	dv3d								
240									spbp0	spri1	lsdr	spbp2	spri3	ssdr		
260																lptp
300	mvn	btd		cmpn		dtb			easp1	eawp1	easp3	eawp3				
320									easp5	eawp5	easp7	eawp7				
340									epp1	epp3	epp5	epp7				
360									epp4	epp6	epp8	epp9				
400																
420																
440				sareg				spl								
460				lareg				lpl								
500	a9bd	a6bd	a4bd	abd				awd								
520	s9bd	s6bd	s4bd	sbd				swd			camp					
540	ara0	ara1	ara2	ara3	ara4	ara5	ara6	ara7								
560	aar0	aar1	aar2	aar3	aar4	aar5	aar6	aar7								sptp
600	trtn	trtf			tmoz	tpnz	ttn									
620																
640	arn0	arn1	arn2	arn3	arn4	arn5	arn6	arn7	spbp4	spri5	spbp6	spri7				
660	nar0	nar1	nar2	nar3	nar4	nar5	nar6	nar7								
700																
720																
740	sar0	sar1	sar2	sar3	sar4	sar5	sar6	sar7								
760	lar0	lar1	lar2	lar3	lar4	lar5	lar6	lar7					sra	lra		

Figure A-1(cont). Processor Operation Code Map

Processor Code	Meaning	ALM keyword
AR	Reference through pointer register.	pr
RL	Names a register containing data length.	rl
ID	Indirect word pointer	id

Figure A-2. EIS MF Codes

Refer to Section 4, "EIS Modification Fields (MF)" for an example of MF field modification using the mlr instruction.

APPENDIX B

ALPHABETIC OPERATION CODE LIST

This appendix presents a listing of all processor instruction operation codes sorted alphabetically on mnemonic. It also includes the micro operations required by the mve and mvne edit instructions. The columns from left to right list the mnemonic, octal operation code value, the functional class, the page number in Section 4 of the instruction description, and the instruction name.

The functional class codes are:

FIX	Fixed Point
BOOL	Boolean Operations
FLT	Floating Point
PREG	Pointer Register
PRIV	Privileged
MISC	Miscellaneous
EIS	Extended Instruction Set
TXFR	Transfer of Control
MOP	EIS Micro Operations

<u>Mnemonic</u>	<u>Code</u>	<u>Class</u>	<u>Page</u>	<u>Name</u>
a4bd	502(1)	EIS	183	Add 4-bit Character Displacement to AR
a6bd	501(1)	EIS	184	Add 6-bit Character Displacement to AR
a9bd	500(1)	EIS	184	Add 9-bit Character Displacement to AR
aarn	56n(1)	EIS	177	Alphanumeric Descriptor to AR _n
abd	503(1)	EIS	185	Add Bit Displacement to AR
absa	212(0)	PRIV	176	Absolute Address to A-Register
ad2d	202(1)	EIS	230	Add Using Two Decimal Operands
ad3d	222(1)	EIS	233	Add Using Three Decimal Operands
ada	075(0)	FIX	42	Add to A-Register
adaq	077(0)	FIX	42	Add to AQ-Register
ade	415(0)	FLT	109	Add to Exponent
adl	033(0)	FIX	43	Add Low to AQ-Register
adla	035(0)	FIX	43	Add Logical to A-Register
adlaq	037(0)	FIX	44	Add Logical to AQ-Register
adlq	036(0)	FIX	44	Add Logical to Q-Register
adlxn	02n(0)	FIX	45	Add Logical to Xn
adq	076(0)	FIX	45	Add to Q-Register
adwp0	050(0)	PREG	134	Add to Word Number of PR0
adwp1	051(0)	PREG	134	Add to Word Number of PR1
adwp2	052(0)	PREG	134	Add to Word Number of PR2
adwp3	053(0)	PREG	134	Add to Word Number of PR3
adwp4	150(0)	PREG	134	Add to Word Number of PR4
adwp5	151(0)	PREG	134	Add to Word Number of PR5
adwp6	152(0)	PREG	134	Add to Word Number of PR6
adwp7	153(0)	PREG	134	Add to Word Number of PR7

Mnemonic Code Class Page Name

adxn	06n(0)	FIX	46	Add to Xn
alr	775(0)	FIX	36	A-Register Left Rotate
als	735(0)	FIX	36	A-Register Left Shift
ana	375(0)	BOOL	70	AND to A-Register
anaq	377(0)	BOOL	70	AND to AQ-Register
anq	376(0)	BOOL	71	AND to Q-Register
ansa	355(0)	BOOL	71	AND to Storage from A-Register
ansq	356(0)	BOOL	72	AND to Storage from Q-Register
ansxn	34n(0)	BOOL	72	AND to Storage from Xn
anxn	36n(0)	BOOL	73	AND to Xn
aos	054(0)	FIX	46	Add One to Storage
aran	54n(1)	EIS	180	ARn to Alphanumeric Descriptor
arl	777(0)	FIX	37	A-Register Right Logical Shift
arnn	64n(1)	EIS	180	ARn to Numeric Descriptor
ars	737(0)	FIX	37	A-Register Right Shift
asa	055(0)	FIX	46	Add Stored to A-Register
asq	056(0)	FIX	47	Add Stored to Q-Register
asxn	04n(0)	FIX	47	Add Stored to Xn
awca	077(0)	FIX	48	Add With Carry to A-Register
awcq	072(0)	FIX	48	Add With Carry to Q-Register
awd	507(1)	EIS	186	Add Word Displacement to AR
bcd	505(0)	MISC	155	Binary-to-BCD
btd	301(1)	EIS	226	Binary-to-Decimal Convert
call6	713(0)	TXFR	111	Call (using PR6 and PR7)
camp	532(1)	PRIV	168	Clear Associative Memory Pages
cams	532(0)	PRIV	168.1	Clear Associative Memory Segments
cana	315(0)	BOOL	82	Comparative AND with A-Register
canaq	317(0)	BOOL	82	Comparative AND with AQ-Register
canq	316(0)	BOOL	83	Comparative AND with Q-Register
canxn	30n(0)	BOOL	83	Comparative AND with Xn
cioc	015(0)	PRIV	173	Connect Input/Output Channel
cmg	405(0)	FIX	64	Compare Magnitude
cmk	211(0)	FIX	64	Compare Masked
cmpa	115(0)	FIX	65	Compare with A-Register
cmpaq	117(0)	FIX	65	Compare with AQ-Register
cmpb	066(1)	EIS	222	Compare Bit Strings
cmpe	106(1)	EIS	191	Compare Alphanumeric Character Strings
cmpn	303(1)	EIS	210	Compare Numeric
cmpq	116(0)	FIX	66	Compare with Q-Register
cmpxn	10n(0)	FIX	67	Compare with Xn
cnaa	215(0)	BOOL	84	Comparative NOT with A-Register
cnaaq	217(0)	BOOL	84	Comparative NOT with AQ-Register
cnaq	216(0)	BOOL	84	Comparative NOT with Q-Register
cnaxn	20n(0)	BOOL	85	Comparative NOT with Xn
csl	060(1)	EIS	218	Combine Bit Strings Left
csr	061(1)	EIS	220	Combine Bit Strings Right
cwl	111(0)	FIX	68	Compare With Limits
dfad	477(0)	FLT	90	Double-Precision Floating Add
dfcmg	427(0)	FLT	107	Double-Precision Floating Compare Magnitude
dfcmp	517(0)	FLT	107	Double-Precision Floating Compare
dfdi	527(0)	FLT	99	Double-Precision Floating Divide Inverted
dfdvd	567(0)	FLT	99	Double-Precision Floating Divide
dfld	433(0)	FLT	86	Double-Precision Floating Load
dfmp	463(0)	FLT	96	Double-Precision Floating Multiply
dfrd	473(0)	FLT	105	Double-Precision Floating Round

<u>Mnemonic</u>	<u>Code</u>	<u>Class</u>	<u>Page</u>	<u>Name</u>
dfsb	577(0)	FLT	93	Double-Precision Floating Subtract
dfst	457(0)	FLT	87	Double-Precision Floating Store
dfstr	472(0)	FLT	87	Double-Precision Floating Store Rounded
dis	616(0)	PRIV	176	Delay Until Interrupt Signal
div	506(0)	FIX	59	Divide Integer
dr1	002(0)	MISC	137	Derail
dtb	305(1)	EIS	228	Decimal-to-Binary Convert
dufa	437(0)	FLT	90	Double-Precision Unnormalized Floating Add
dufm	423(0)	FLT	96	Double-Precision Unnormalized Floating Multiply
dufs	537(0)	FLT	93	Double-Precision Unnormalized Floating Subtract
dv2d	207(1)	EIS	242	Divide Using Two Decimal Operands
dv3d	227(1)	EIS	243	Divide Using Three Decimal Operands
dvf	507(0)	FIX	60	Divide Fraction
ea	635(0)	FIX	16	Effective Address to A-Register
eaq	636(0)	FIX	16	Effective Address to Q-Register
easp0	311(0)	PREG	124	Effective Address to Segment Number of PR0
easp1	310(1)	PREG	124	Effective Address to Segment Number of PR1
easp2	313(0)	PREG	124	Effective Address to Segment Number of PR2
easp3	312(1)	PREG	124	Effective Address to Segment Number of PR3
easp4	331(0)	PREG	124	Effective Address to Segment Number of PR4
easp5	330(1)	PREG	124	Effective Address to Segment Number of PR5
easp6	333(0)	PREG	124	Effective Address to Segment Number of PR6
easp7	332(1)	PREG	124	Effective Address to Segment Number of PR7
eawp0	310(0)	PREG	125	Effective Address to Word/Bit Number of PR0
eawp1	311(1)	PREG	125	Effective Address to Word/Bit Number of PR1
eawp2	312(0)	PREG	125	Effective Address to Word/Bit Number of PR2
eawp3	313(1)	PREG	125	Effective Address to Word/Bit Number of PR3
eawp4	330(0)	PREG	125	Effective Address to Word/Bit Number of PR4
eawp5	331(1)	PREG	125	Effective Address to Word/Bit Number of PR5
eawp6	332(0)	PREG	125	Effective Address to Word/Bit Number of PR6
eawp7	333(1)	PREG	125	Effective Address to Word/Bit Number of PR7
eaxn	62n(0)	FIX	17	Effective Address to Xn
epaq	213(0)	PREG	135	Effective Pointer to AQ-Register
epbp0	350(1)	PREG	126	Effective Pointer at Base to PR0
epbp1	351(0)	PREG	126	Effective Pointer at Base to PR1
epbp2	352(1)	PREG	126	Effective Pointer at Base to PR2
epbp3	353(0)	PREG	126	Effective Pointer at Base to PR3
epbp4	370(1)	PREG	126	Effective Pointer at Base to PR4
epbp5	371(0)	PREG	126	Effective Pointer at Base to PR5
epbp6	372(1)	PREG	126	Effective Pointer at Base to PR6
epbp7	373(0)	PREG	126	Effective Pointer at Base to PR7
epp0	350(0)	PREG	127	Effective Pointer to PR0
epp1	351(1)	PREG	127	Effective Pointer to PR1
epp2	352(0)	PREG	127	Effective Pointer to PR2
epp3	353(1)	PREG	127	Effective Pointer to PR3
epp4	370(0)	PREG	127	Effective Pointer to PR4
epp5	371(1)	PREG	127	Effective Pointer to PR5
epp6	372(0)	PREG	127	Effective Pointer to PR6
epp7	373(1)	PREG	127	Effective Pointer to PR7
era	675(0)	BOOL	78	Exclusive OR to A-Register
eraq	677(0)	BOOL	78	Exclusive OR to AQ-Register
erq	676(0)	BOOL	79	Exclusive OR to Q-Register
ersa	655(0)	BOOL	79	Exclusive OR to Storage with A-Register
ersq	656(0)	BOOL	80	Exclusive OR to Storage with Q-Register
ersxn	64n(0)	BOOL	80	Exclusive OR to Storage with Xn

<u>Mnemonic</u>	<u>Code</u>	<u>Class</u>	<u>Page</u>	<u>Name</u>
erxn	66n(0)	BOOL	81	Exclusive OR to X _n
fad	475(0)	FLT	91	Floating Add
fcmg	425(0)	FLT	108	Floating Compare Magnitude
fcmp	515(0)	FLT	108	Floating Compare
fdi	525(0)	FLT	100	Floating Divide Inverted
fdv	565(0)	FLT	101	Floating Divide
fld	431(0)	FLT	86	Floating Load
fmp	461(0)	FLT	97	Floating Multiply
fneg	513(0)	FLT	103	Floating Negate
fno	573(0)	FLT	104	Floating Normalize
frd	471(0)	FLT	105	Floating Round
fsb	575(0)	FLT	94	Floating Subtract
fst	455(0)	FLT	88	Floating Store
fstr	470(0)	FLT	88	Floating Store Rounded
fszn	430(0)	FLT	109	Floating Set Zero and Negative Indicators
gtb	774(0)	MISC	156	Gray-to-Binary Convert
larn	76n(1)	EIS	178	Load AR _n
lareg	463(1)	EIS	178	Load AR _S
lbar	230(0)	FIX	157	Load BAR
lca	335(0)	FIX	17	Load Complement into A-Register
lcaq	337(0)	FIX	18	Load Complement into AQ-Register
lcpr	674(0)	PRIV	157.1	Load Central Processor Register
lcq	336(0)	FIX	18	Load Complement into Q-Register
lcn	32n(0)	FIX	19	Load Complement into X _n
lda	235(0)	FIX	19	Load A-Register
ldac	034(0)	FIX	20	Load A-Register and Clear
ldaq	237(0)	FIX	20	Load AQ-Register
ldbr	232(0)	PRIV	158	Load Descriptor Base Register
lde	411(0)	FLT	109	Load Exponent
ldi	634(0)	FIX	21	Load IR
ldq	236(0)	FIX	22	Load Q-Register
ldqc	032(0)	FIX	22	Load Q-Register and Clear
ldt	637(0)	PRIV	159	Load Timer Register
ldxn	22n(0)	FIX	23	Load X _n
llr	777(0)	FIX	38	Long Left Rotate
lls	737(0)	FIX	38	Long Left Shift
lpl	467(1)	EIS	178	Load Pointers and Lengths
lpri	173(0)	PREG	128	Load PRs from ITS Pairs
lprpn	76n(0)	PREG	128	Load PRn from Packed Pointer
lptp	257(1)	PRIV	159	Load Page Table Pointers
lptr	173(1)	PRIV	160	Load Page Table Registers
lra	774(1)	PRIV	160	Load Ring Alarm Register
lreg	073(0)	FIX	23	Load Registers
lrl	773(0)	FIX	39	Long Right Logical
lrs	733(0)	FIX	39	Long Right Shift
lsdp	257(0)	PRIV	161	Load Segment Descriptor Pointers
lsdr	232(1)	PRIV	161	Load Segment Descriptor Registers
lxln	72n(0)	FIX	24	Load X _n from Lower
mlr	100(1)	EIS	202	Move Alphanumeric Left to Right
mme	001(0)	MISC	140	Master Mode Entry
mme2	004(0)	MISC	141	Master Mode Entry 2
mme3	005(0)	MISC	141	Master Mode Entry 3
mme4	007(0)	MISC	142	Master Mode Entry 4
mp2d	206(1)	EIS	239	Multiply Using Two Decimal Operands
mp3d	226(1)	EIS	240	Multiply Using Three Decimal Operands

<u>Mnemonic</u>	<u>Code</u>	<u>Class</u>	<u>Page</u>	<u>Name</u>
mpf	401(0)	FIX	57	Multiply Fraction
mpy	402(0)	FIX	57	Multiply Integer
mrl	101(1)	EIS	204	Move Alphanumeric Right to Left
mve	020(1)	EIS	205	Move Alphanumeric Edited
mvn	300(1)	EIS	213	Move Numeric
mvne	024(1)	EIS	216	Move Numeric Edited
mvt	160(1)	EIS	207	Move Alphanumeric with Translation
narn	66n(1)	EIS	179	Numeric Descriptor to ARn
neg	531(0)	FIX	62	Negate (A-Register)
negl	533(0)	FIX	62	Negate Long (AQ-Register)
nop	011(0)	MISC	143	No Operation
ora	275(0)	BOOL	74	OR to A-Register
oraq	274(0)	BOOL	74	OR to AQ-Register
orq	276(0)	BOOL	75	OR to Q-Register
orsa	255(0)	BOOL	75	OR to Storage from A-Register
orsq	256(0)	BOOL	76	OR to Storage from Q-Register
orsxn	24n(0)	BOOL	76	OR to Storage from Xn
orxn	26n(0)	BOOL	77	OR to Xn
puls1	012(0)	MISC	143	Pulse 1
puls2	013(0)	MISC	144	Pulse 2
qlr	776(0)	FIX	40	Q-Register Left Rotate
qls	736(0)	FIX	40	Q-Register Left Shift
qrl	772(0)	FIX	41	Q-Register Right Logical Shift
qrs	732(0)	FIX	41	Q-Register Right Shift
rccl	633(0)	MISC	136	Read Calendar Clock
rcu	613(0)	PRIV	162	Restore Control Unit
ret	630(0)	TXFR	112	Return
rmcm	233(0)	PRIV	170	Read Memory Controller Mask
rpd	560(0)	MISC	145	Repeat Double
rpl	500(0)	MISC	148	Repeat Link
rpt	520(0)	MISC	150	Repeat
rscr	413(0)	PRIV	170	Read System Controller Register
rsw	231(0)	PRIV	171	Read Switches
rtcd	610(0)	TXFR	113	Return Control Double
s4bd	522(1)	EIS	187	Subtract 4-bit Displacement from AR
s6bd	521(1)	EIS	188	Subtract 6-bit Displacement from AR
s9bd	520(1)	EIS	188	Subtract 9-bit Displacement from AR
sarn	74n(1)	EIS	181	Store ARn
sar \bar{e} g	443(1)	EIS	182	Store AR \bar{s}
sb2d	203(1)	EIS	236	Subtract Using Two Decimal Operands
sb3d	223(1)	EIS	237	Subtract Using Three Decimal Operands
sba	175(0)	FIX	50	Subtract from A-Register
sbaq	177(0)	FIX	50	Subtract from AQ-Register
sbar	550(0)	MISC	154	Store BAR
sbd	523(1)	EIS	189	Subtract Bit Displacement from AR
sbla	135(0)	FIX	50	Subtract Logical from A-Register
sblaq	137(0)	FIX	51	Subtract Logical from AQ-Register
sblq	136(0)	FIX	51	Subtract Logical from Q-Register
sblxn	12n(0)	FIX	52	Subtract Logical from Xn
sbq	176(0)	FIX	52	Subtract from Q-Register
sbxn	16n(0)	FIX	53	Subtract from Xn
scd	120(1)	EIS	193	Scan Character Double
scdr	121(1)	EIS	194	Scan Character Double Reverse
scm	124(1)	EIS	196	Scan With Mask
scmr	125(1)	EIS	198	Scan With Mask Reverse

<u>Mnemonic</u>	<u>Code</u>	<u>Class</u>	<u>Page</u>	<u>Name</u>
scpr	452(0)	PRIV	163	Store Central Processor Register
scu	657(0)	PRIV	164	Store Control Unit
sdbbr	154(0)	PRIV	164	Store Descriptor Base Register
smcm	553(0)	PRIV	173	Set Memory Controller Mask
smic	451(0)	PRIV	174	Set Memory Interrupt Cells
spbp0	250(1)	PREG	130	Store Segment Base Pointer of PR0
spbp1	251(0)	PREG	130	Store Segment Base Pointer of PR1
spbp2	252(1)	PREG	130	Store Segment Base Pointer of PR2
spbp3	253(0)	PREG	130	Store Segment Base Pointer of PR3
spbp4	650(1)	PREG	130	Store Segment Base Pointer of PR4
spbp5	651(0)	PREG	130	Store Segment Base Pointer of PR5
spbp6	652(1)	PREG	130	Store Segment Base Pointer of PR6
spbp7	653(0)	PREG	130	Store Segment Base Pointer of PR7
spl	447(1)	EIS	182	Store Pointers and Lengths
spri	254(0)	PREG	131	Store PRs as ITS Pairs
spri0	250(0)	PREG	132	Store PR0 as an ITS Pair
spri1	251(1)	PREG	132	Store PR1 as an ITS Pair
spri2	252(0)	PREG	132	Store PR2 as an ITS Pair
spri3	253(1)	PREG	132	Store PR3 as an ITS Pair
spri4	650(0)	PREG	132	Store PR4 as an ITS Pair
spri5	651(1)	PREG	132	Store PR5 as an ITS Pair
spri6	652(0)	PREG	132	Store PR6 as an ITS Pair
spri7	653(1)	PREG	132	Store PR7 as an ITS Pair
sprpn	54n(0)	PREG	133	Store PRn as a Packed Pointer
sptp	557(1)	PRIV	165	Store Page Table Pointers
sptr	154(1)	PRIV	165.1	Store Page Table Registers
sra	754(1)	MISC	153	Store Ring Alarm Register
sreg	753(0)	FIX	25	Store Registers
ssa	155(0)	FIX	53	Subtract Stored from A-Register
sscr	057(0)	PRIV	174	Set System Controller Register
ssdp	557(0)	PRIV	165.2	Store Segment Descriptor Pointers
ssdr	254(1)	PRIV	166	Store Segment Descriptor Registers
ssq	154(0)	FIX	54	Subtract Stored from Q-Register
ssxn	14n(0)	FIX	54	Subtract Stored from Xn
sta	755(0)	FIX	26	Store A-Register
stac	354(0)	FIX	26	Store A-Register Conditional
stacq	654(0)	FIX	27	Store A-Register Conditional on Q-Register
staq	757(0)	FIX	27	Store AQ-Register
stba	551(0)	FIX	28	Store 9-bit Bytes of A-Register
stbq	552(0)	FIX	29	Store 9-bit Bytes of Q-Register
stc1	554(0)	FIX	29	Store Instruction Counter + 1
stc2	750(0)	FIX	30	Store Instruction Counter + 2
stca	751(0)	FIX	30	Store 6-bit Characters of A-Register
stcd	357(0)	FIX	32	Store Control Double
stcq	752(0)	FIX	31	Store 6-bit Characters of Q-Register
ste	456(0)	FLT	110	Store Exponent
sti	754(0)	FIX	32	Store IR
stq	756(0)	FIX	33	Store Q-Register
stt	454(0)	FIX	33	Store Timer Register
stxn	74n(0)	FIX	34	Store Xn
stz	450(0)	FIX	34	Store Zero
swca	171(0)	FIX	55	Subtract With Carry from A-Register
swcq	172(0)	FIX	55	Subtract With Carry from Q-Register
swd	527(1)	EIS	190	Subtract Word Displacement from AR
sxl _n	44n(0)	FIX	34	Store Xn in Lower

<u>Mnemonic</u>	<u>Code</u>	<u>Class</u>	<u>Page</u>	<u>Name</u>
szn	234(0)	FIX	69	Set Zero and Negative Indicators
sznc	214(0)	FIX	69	Set Zero and Negative Indicators and Clear
sztl	064(1)	EIS	224	Set Zero/Truncation Indicators with Bit String Left
sztr	065(1)	EIS	225	Set Zero/Truncation Indicators with Bit String Right
tct	164(1)	EIS	199	Test Character and Translate
tctr	165(1)	EIS	201	Test Character and Translate Reverse
teo	614(0)	TXFR	114	Transfer on Exponent Overflow
teu	615(0)	TXFR	114	Transfer on Exponent Underflow
tmi	604(0)	TXFR	115	Transfer on Minus
tmoz	604(1)	TXFR	115	Transfer on Minus or Zero
tnc	602(0)	TXFR	115	Transfer on No Carry
tnz	601(0)	TXFR	116	Transfer on Nonzero
tov	617(0)	TXFR	116	Transfer on Overflow
tpl	605(0)	TXFR	117	Transfer on Plus
tpnz	605(1)	TXFR	117	Transfer on Plus and Nonzero
tra	710(0)	TXFR	118	Transfer
trc	603(0)	TXFR	118	Transfer on Carry
trtf	601(1)	TXFR	118	Transfer on Truncation Indicator Off
trtn	600(1)	TXFR	119	Transfer on Truncation Indicator On
tsp0	270(0)	TXFR	120	Transfer and Set PR0
tsp1	271(0)	TXFR	120	Transfer and Set PR1
tsp2	272(0)	TXFR	120	Transfer and Set PR2
tsp3	273(0)	TXFR	120	Transfer and Set PR3
tsp4	670(0)	TXFR	120	Transfer and Set PR4
tsp5	671(0)	TXFR	120	Transfer and Set PR5
tsp6	672(0)	TXFR	120	Transfer and Set PR6
tsp7	673(0)	TXFR	120	Transfer and Set PR7
tss	715(0)	TXFR	120	Transfer and Set Slave
tsxn	70n(0)	TXFR	121	Transfer and Set Xn
ttf	607(0)	TXFR	122	Transfer on Tally Runout Indicator Off
ttn	606(1)	TXFR	122	Transfer on Tally Runout Indicator On
tze	600(0)	TXFR	122	Transfer on Zero
ufa	435(0)	FLT	91	Unnormalized Floating Add
ufm	421(0)	FLT	98	Unnormalized Floating Multiply
ufs	535(0)	FLT	95	Unnormalized Floating Subtract
xec	716(0)	MISC	138	Execute
xed	717(0)	MISC	139	Execute Double

EIS Micro Operations

cht	21	MOP	249	Change Table
enf	02	MOP	249	End Floating Suppression
ign	14	MOP	250	Ignore Source Character
insa	11	MOP	250	Insert Asterisk on Suppression
insb	10	MOP	251	Insert Blank on Suppression
insm	01	MOP	251	Insert Table Entry 1 Multiple
insn	12	MOP	251	Insert on Negative
insp	13	MOP	252	Insert on Positive
lte	20	MOP	252	Load Table Entry
mflc	07	MOP	253	Move with Float Currency Symbol Insertion
mfls	06	MOP	253	Move with Float Sign Insertion
mors	17	MOP	254	Move and OR Sign
mses	16	MOP	255	Move and Set Sign
mvc	15	MOP	255	Move Source Character
mvza	05	MOP	256	Move with Zero Suppression and Asterisk Replacement

<u>Mnemonic</u>	<u>Code</u>	<u>Class</u>	<u>Page</u>	<u>Name</u>
mvzb	04	MOP	256	Move with Zero Suppression and Blank Replacement
ses	03	MOP	257	Set End Suppression

APPENDIX C

ADDRESS MODIFIERS

	00	01	02	03	04	05	06	07	
00		au	qu	du	ic	al	ql	d1	r
10	0	1	2	3	4	5	6	7	
20	n*	au*	qu*		ic*	al*	ql*		ri
30	0*	1*	2*	3*	4*	5*	6*	7*	
40	f1	itp		its	sd	scr	f2	f3	it
50	ci	i	sc	ad	di	dic	id	idc	
60	*n	*au	*qu	*du	*ic	*al	*ql	*d1	ir
70	*0	*1	*2	*3	*4	*5	*6	*7	

NONSTANDARD MODIFIERS

<u>Instruction</u>	<u>Tag</u>	<u>Meaning</u>
scpr	00	Store appending unit history register
	01	Store fault register
	06	Store mode register
	10	Store decimal unit history register
	20	Store control unit history register
	40	Store operations unit history register
lcpr	02	Load cache mode register
	03	Load 0s into all history registers
	04	Load mode register
	07	Load 1s into all history registers
stca		See description in Section 4
stcq		See description in Section 4
stba		See description in Section 4
stbq		See description in Section 4

DPS/LEVEL 68
& DPS 8M

**MULTICS PROCESSOR MANUAL
ADDENDUM B**

SUBJECT

Additions and Changes to the Multics Processor Manual

SPECIAL INSTRUCTIONS

This is the second addendum to AL39, Revision 1 dated April 1979. Insert the attached pages into the manual according to the collating instructions on the back of this cover. See the Preface for additional information regarding this document. Change bars in the margin indicate technical additions and changes; asterisks denote deletions.

Note:

Insert this cover sheet after the manual cover to indicate the updating of the document with Addendum B.

ORDER NUMBER

AL39-01B

February 1982

34293
5C482
Printed in U.S.A.

Honeywell

COLLATING INSTRUCTIONS

To update the manual, remove old pages and insert new pages as follows:

Remove

manual cover ✓
title page, preface ✓

iii through ix ✓

1-5, blank ✓

2-5 through 2-8 ✓
2-11, 2-12 ✓

Section 3 ✓

4-11.1 through 4-16 ✓
4-25 through 4-28 ✓
4-57, 4-58 ✓
4-85, 4-86 ✓
4-135, 4-136 ✓
4-139, 4-140 ✓
4-157, 4-158 ✓

4-159 through 4-176 ✓

4-193 through 4-202 ✓
4-225 through 4-228 ✓
4-249 through 4-257 ✓

6-19 through 6-24 ✓
B-1 through B-8 ✓

i-1 through i-9

Insert

manual cover ✓
title page, preface ✓

iii through ix ✓

1-5, blank ✓

2-5 through 2-8 ✓
2-11, 2-12 ✓

Section 3 ✓

4-11.1 through 4-16 ✓
4-25 through 4-28 ✓
4-57, 4-58 ✓
4-85, 4-86 ✓
4-135, 4-136 ✓
4-139, 4-140 ✓
4-157, blank ✓
4-157.1, 4-158 ✓
4-159 through 4-165 ✓
4-165.1, 4-165.2 ✓
4-166 through 4-168 ✓
4-168.1, blank ✓
4-169 through 4-176 ✓
4-193 through 4-202 ✓
4-225 through 4-228 ✓
4-249 through 4-257, blank ✓

6-19 through 6-24 ✓
B-1 through B-8 ✓

i-1 through i-10

The information and specifications in this document are subject to change without notice. This document contains information about Honeywell products or services that may not be available outside the United States. Consult your Honeywell Marketing Representative.

INDEX

- 29
 - The Use of Bit 29 6-19
- A
 - Accumulator Register (A) 3-2
- ABBREVIATIONS
 - Abbreviations and Symbols 4-4
- ABSOLUTE
 - Absolute Mode 1-3
- ACCUMULATOR
 - Accumulator Register (A) 3-2
- ACCUMULATOR-QUOTIENT
 - Accumulator-Quotient Register (AQ) 3-3
- ADDITION
 - EIS - Decimal Addition 4-230
 - Fixed-Point Addition 4-42
 - Floating-Point Addition 4-90
- Address
 - Address appending 1-2
 - Address Appending Sequences 5-6
 - Address modification 1-2
 - Address Modifier (TAG) Field 6-3
 - Address Register (ARn) 3-12
 - base address register 1-4
 - Base Address Register (BAR) 3-9
 - Common Computed Address Formation 6-6
 - EIS - Address Register Load 4-177
 - EIS - Address Register Special Arithmetic 4-183
 - EIS - Address Register Store 4-180
 - General Computed Address Modification Types 6-5
 - Main Memory Address Generation 5-3, 5-5
 - Main Memory Addresses 4-4
 - Pointer Register Address Arithmetic 4-134
 - special address modifiers 6-19
 - Store Base Address Register 4-154
 - virtual address formation 6-1, 6-19
 - VIRTUAL ADDRESS FORMATION FOR EXTENDED INSTRUCTION SET 6-24
- ADDRESSING
 - CHANGING ADDRESSING MODES 5-5
- ADDRESSING (cont)
 - Character- and Bit-String Addressing 6-26
 - modes of main memory addressing 1-3
- ALARM
 - Ring Alarm Register 4-153
 - Ring Alarm Register (RALR) 3-10
- ALPHANUMERIC
 - Alphanumeric data 2-12
 - ALPHANUMERIC EDIT 4-248
 - ALPHANUMERIC OPERAND DESCRIPTOR FORMAT 4-12
 - EIS - Alphanumeric Compare 4-191
 - EIS - Alphanumeric Move 4-202
- APPEND
 - append mode 5-2
- append mode 1-4
- Appending
 - Address appending 1-2
 - Address Appending Sequences 5-6
 - Appending Unit 1-4
 - Appending Unit (APU) History Register - DPS 8M 3-51
 - Appending Unit (APU) History Register - DPS and L68 3-49
 - APPENDING UNIT DATA WORD FORMATS 5-9
 - APPENDING UNIT OPERATION WITH RING MECHANISM 8-3
- APU
 - Appending Unit (APU) History Register - DPS 8M 3-51
 - Appending Unit (APU) History Register - DPS and L68 3-49
- AQ
 - Accumulator-Quotient Register (AQ) 3-3
- ARITHMETIC
 - EIS - Address Register Special Arithmetic 4-183
 - FIXED-POINT ARITHMETIC 4-16
 - Pointer Register Address Arithmetic 4-134

ARN
 Address Register (ARn) 3-12

ASSEMBLY
 Associative Memory Assembly 1-4

ASSIGNMENT
 Micro Operation Code Assignment Map
 4-257

ASSOCIATIVE
 Associative Memory Assembly 1-4
 Page Table Word Associative Memory
 (PTWAM) 3-20
 Privileged - Clear Associative
 Memory 4-168
 Segment Descriptor Word Associative
 Memory (SDWAM) - DPS/L68 and
 DPS 8M 3-18

BAR
 BAR mode 1-4
 Base Address Register (BAR) 3-9

BASE
 base address register 1-4
 Base Address Register (BAR) 3-9
 Descriptor Segment Base Register
 (DSBR) 3-16
 Store Base Address Register 4-154

BASIC
 basic instructions 4-6
 basic operations 4-1

BINARY
 binary number system 2-1
 FIXED-POINT BINARY DATA 2-4
 FLOATING-POINT BINARY DATA 2-6

BIT
 EIS - Bit String Combine 4-218
 EIS - Bit String Compare 4-222
 EIS - Bit String Set Indicators
 4-224
 The Use of Bit 29 6-19

BIT-STRING
 BIT-STRING OPERAND DESCRIPTOR FORMAT
 4-15
 Character- and Bit-String Addressing
 6-26

BOOLEAN
 Boolean AND 4-70
 Boolean Comparative AND 4-82
 Boolean Comparative NOT 4-84
 Boolean EXCLUSIVE OR 4-78
 BOOLEAN OPERATION INSTRUCTIONS 4-70
 Boolean OR 4-74

CACHE 9-5
 Cache Memory Control in Segment
 Descriptor Words 9-6
 Cache Mode Register (CMR) - DPS and
 L68 3-32

Cache Mode Register (CMR) Format - DPS
 8M 3-34

CALENDAR
 Calendar Clock 4-136

CHANGING
 CHANGING ADDRESSING MODES 5-5

CHARACTER-
 Character- and Bit-String Addressing
 6-26

CLEAR
 Privileged - Clear Associative
 Memory 4-168

CLOCK
 Calendar Clock 4-136

CMR
 Cache Mode Register (CMR) - DPS and
 L68 3-32

CODE
 Micro Operation Code Assignment Map
 4-257
 mnemonic code 4-2

COMBINE
 EIS - Bit String Combine 4-218

COMMON
 Common Computed Address Formation
 6-6

COMPARATIVE
 Boolean Comparative AND 4-82
 Boolean Comparative NOT 4-84

COMPARE
 EIS - Alphanumeric Compare 4-191
 EIS - Bit String Compare 4-222
 EIS - Numeric Compare 4-210
 Floating-Point Compare 4-107

COMPARISON
 Fixed-Point Comparison 4-64

COMPUTED
 Common Computed Address Formation
 6-6
 General Computed Address
 Modification Types 6-5

CONFIGURATION
 Configuration Switch Data - DPS 8M
 3-56
 Configuration Switch Data - DPS and
 L68 3-54
 Privileged - Configuration and
 Status 4-170

CONTROL
 Cache Memory Control in Segment
 Descriptor Words 9-6
 Control Unit 1-4

CONTROL (cont)
Control Unit (CU) History Register -
DPS 8M 3-39
Control Unit (CU) History Register -
DPS and L68 3-37
Control Unit Data 3-58
Privileged - System Control 4-173

CONVERSION
EIS - Data Conversion 4-226

CU
Control Unit (CU) History Register -
DPS 8M 3-39
Control Unit (CU) History Register -
DPS and L68 3-37

CYCLE
FAULT CYCLE SEQUENCE 7-1

DATA
Alphanumeric data 2-12
APPENDING UNIT DATA WORD FORMATS
5-9
Configuration Switch Data - DPS 8M
3-56
Configuration Switch Data - DPS and
L68 3-54
Control Unit Data 3-58
DATA PARITY 2-4
DECIMAL DATA 2-9
Decimal Unit Data 3-63
EIS - Data Conversion 4-226
FIXED-POINT BINARY DATA 2-4
Fixed-Point Data Movement Load 4-16
Fixed-Point Data Movement Shift
4-36
Fixed-Point Data Movement Store
4-25
FLOATING-POINT BINARY DATA 2-6
Floating-Point Data Movement Load
4-86
Floating-Point Data Movement Store
4-87
Pointer Register Data Movement Load
4-124
Pointer Register Data Movement Store
4-130

DECIMAL
DECIMAL DATA 2-9
Decimal Unit 1-5
Decimal Unit Data 3-63
Decimal unit history register 3-43
EIS - Decimal Addition 4-230
EIS - Decimal Division 4-242
EIS - Decimal Multiplication 4-239
EIS - Decimal Subtraction 4-236

Decimal/Operations (DU/OU) History
Register - DPS 8M 3-46

Derail 4-137

DESCRIPTIONS
FAULT DESCRIPTIONS 7-4

DESCRIPTOR
ALPHANUMERIC OPERAND DESCRIPTOR
FORMAT 4-12
BIT-STRING OPERAND DESCRIPTOR FORMAT
4-15
Cache Memory Control in Segment
Descriptor Words 9-6
Descriptor Segment Base Register
(DSBR) 3-16
NUMERIC OPERAND DESCRIPTOR FORMAT
4-13
OPERAND DESCRIPTOR INDIRECT POINTER
FORMAT 4-11.1
Segment Descriptor Word (SDW) Format
5-9
Segment Descriptor Word Associative
Memory (SDWAM) - DPS/L68 and
DPS 8M 3-18

DIFFERENCES
MVNE and MVE Differences 4-248

DIVISION
EIS - Decimal Division 4-242
Fixed-Point Division 4-59
Floating-Point Division 4-99

DPS
Appending Unit (APU) History
Register - DPS 8M 3-51
Appending Unit (APU) History
Register - DPS and L68 3-49
Cache Mode Register (CMR) - DPS and
L68 3-32
Configuration Switch Data - DPS 8M
3-56
Configuration Switch Data - DPS and
L68 3-54
Control Unit (CU) History Register -
DPS 8M 3-39
Control Unit (CU) History Register -
DPS and L68 3-37
Fault Register (FR) - DPS and L68
3-23
Mode Register (MR) - DPS and L68
3-27
Segment Descriptor Word Associative
Memory (SDWAM) - DPS/L68 and
DPS 8M 3-18

DPS/L68
Segment Descriptor Word Associative
Memory (SDWAM) - DPS/L68 and
DPS 8M 3-18

DSBR
Descriptor Segment Base Register
(DSBR) 3-16

E
Exponent Register (E) 3-4

EAQ
Exponent-Accumulator-Quotient
Register (EAQ) 3-4

EDIT
ALPHANUMERIC EDIT 4-248

EDIT (cont)
 edit flags 4-247
 edit insertion table 4-246
 NUMERIC EDIT 4-248

EFFECTIVE
 effective segment number generation 6-22

EIS
 EIS - Address Register Load 4-177
 EIS - Address Register Special Arithmetic 4-183
 EIS - Address Register Store 4-180
 EIS - Alphanumeric Compare 4-191
 EIS - Alphanumeric Move 4-202
 EIS - Bit String Combine 4-218
 EIS - Bit String Compare 4-222
 EIS - Bit String Set Indicators 4-224
 EIS - Data Conversion 4-226
 EIS - Decimal Addition 4-230
 EIS - Decimal Division 4-242
 EIS - Decimal Multiplication 4-239
 EIS - Decimal Subtraction 4-236
 EIS - Numeric Compare 4-210
 EIS - Numeric Move 4-213
 EIS multiword instructions 4-2, 4-8
 EIS single-word instructions 4-2, 4-6
 extended instruction set (EIS) operations 4-1

ENTRY
 Master Mode Entry 4-140

EXCLUSIVE
 Boolean EXCLUSIVE OR 4-78

Execute 4-138

Execution
 Instruction execution 1-1

EXPONENT
 Exponent Register (E) 3-4

EXPONENT-ACCUMULATOR-QUOTIENT
 Exponent-Accumulator-Quotient Register (EAQ) 3-4

EXTENDED
 extended instruction set (EIS) operations 4-1
 VIRTUAL ADDRESS FORMATION FOR EXTENDED INSTRUCTION SET 6-24

EXTERNAL
 INTERRUPTS AND EXTERNAL FAULTS 7-8

FAULT
 FAULT CYCLE SEQUENCE 7-1
 FAULT DESCRIPTIONS 7-4
 fault priority groups 7-3
 Fault Register (FR) - DPS and L68 3-23

FAULTS
 Faults and interrupts 1-3, 7-1
 INTERRUPTS AND EXTERNAL FAULTS 7-8

FEATURES
 PROCESSOR FEATURES 1-1

FIELD
 Address Modifier (TAG) Field 6-3
 modification field 4-9

FIXED-POINT
 Fixed-Point Addition 4-42
 FIXED-POINT ARITHMETIC 4-16
 FIXED-POINT BINARY DATA 2-4
 Fixed-Point Comparison 4-64
 Fixed-Point Data Movement Load 4-16
 Fixed-Point Data Movement Shift 4-36
 Fixed-Point Data Movement Store 4-25
 Fixed-Point Division 4-59
 Fixed-Point Miscellaneous 4-69
 Fixed-Point Multiplication 4-57
 Fixed-Point Negate 4-62
 Fixed-Point Subtraction 4-50

FLAGS
 edit flags 4-247

FLOATING-POINT
 Floating-Point Addition 4-90
 FLOATING-POINT BINARY DATA 2-6
 Floating-Point Compare 4-107
 Floating-Point Data Movement Load 4-86
 Floating-Point Data Movement Store 4-87
 Floating-Point Division 4-99
 Floating-Point Miscellaneous 4-109
 Floating-Point Multiplication 4-96
 Floating-Point Negate 4-103
 Floating-Point Normalize 4-104
 Floating-Point Round 4-105
 Floating-Point Subtraction 4-93

FORMAT
 ALPHANUMERIC OPERAND DESCRIPTOR FORMAT 4-12
 BIT-STRING OPERAND DESCRIPTOR FORMAT 4-15
 FORMAT OF INSTRUCTION 4-2
 NUMERIC OPERAND DESCRIPTOR FORMAT 4-13
 OPERAND DESCRIPTOR INDIRECT POINTER FORMAT 4-11.1
 Page Table Word (PTW) Format 5-10
 Segment Descriptor Word (SDW) Format 5-9

FORMATION
 Common Computed Address Formation 6-6
 Page Number Formation 5-3
 virtual address formation 6-1, 6-19
 VIRTUAL ADDRESS FORMATION FOR EXTENDED INSTRUCTION SET 6-24

FORMATS

APPENDING UNIT DATA WORD FORMATS
5-9
INSTRUCTION WORD FORMATS 4-6
unstructured formats 2-2

FR

Fault Register (FR) - DPS and L68
3-23

FRAMES

page frames 1-2

GENERAL

General Computed Address
Modification Types 6-5

GENERATION

effective segment number generation
6-22
Main Memory Address Generation 5-3,
5-5

GROUPS

fault priority groups 7-3

HISTORY

Appending Unit (APU) History
Register - DPS 8M 3-51
Appending Unit (APU) History
Register - DPS and L68 3-49
Control Unit (CU) History Register -
DPS 8M 3-39
Control Unit (CU) History Register -
DPS and L68 3-37
Decimal unit history register 3-43
Operations Unit (OU) History
Register 3-41

ILLEGAL

illegal modifier 4-6

IN

Cache Memory Control in Segment
Descriptor Words 9-6

INDEX

Index Register (Xn) 3-5
Index Values 4-4

INDICATOR

Indicator Register (IR) 3-5

INDICATORS

EIS - Bit String Set Indicators
4-224

INDIRECT

indirect pointers 4-11
Indirect Then Register (ir)
Modification 6-10
Indirect Then Tally (it)
Modification 6-12
INDIRECT TO POINTER (ITP)
MODIFICATION 6-20
INDIRECT TO SEGMENT (ITS)
MODIFICATION 6-21
indirect word 4-8

INDIRECT (cont)

OPERAND DESCRIPTOR INDIRECT POINTER
FORMAT 4-11.1
Register Then Indirect (ri)
Modification 6-9

INSERTION

edit insertion table 4-246

INSTRUCTION

extended instruction set (EIS)
operations 4-1
FORMAT OF INSTRUCTION 4-2
Instruction execution 1-1
INSTRUCTION WORD FORMATS 4-6
VIRTUAL ADDRESS FORMATION FOR
EXTENDED INSTRUCTION SET 6-24

INSTRUCTIONS

basic instructions 4-6
BOOLEAN OPERATION INSTRUCTIONS 4-70
EIS multiword instructions 4-2, 4-8
EIS single-word instructions 4-2,
4-6
machine instructions 4-1

INTERRUPTS

Faults and interrupts 1-3, 7-1
INTERRUPTS AND EXTERNAL FAULTS 7-8

IR

Indicator Register (IR) 3-5
Indirect Then Register (ir)
Modification 6-10

IT

Indirect Then Tally (it)
Modification 6-12

ITP

INDIRECT TO POINTER (ITP)
MODIFICATION 6-20

ITS

INDIRECT TO SEGMENT (ITS)
MODIFICATION 6-21

L68

Appending Unit (APU) History
Register - DPS and L68 3-49
Cache Mode Register (CMR) - DPS and
L68 3-32
Configuration Switch Data - DPS and
L68 3-54
Control Unit (CU) History Register -
DPS and L68 3-37
Fault Register (FR) - DPS and L68
3-23
Mode Register (MR) - DPS and L6L68
3-27

LOAD

EIS - Address Register Load 4-177
Fixed-Point Data Movement Load 4-16
Floating-Point Data Movement Load
4-86
Pointer Register Data Movement Load
4-124

LOAD (cont)
 Register Load 4-157

LOCALITY
 Locality of reference 9-1

MACHINE
 machine instructions 4-1

MAIN
 Main memory 9-1
 Main Memory Address Generation 5-3,
 5-5
 Main Memory Addresses 4-4
 modes of main memory addressing 1-3

MAP
 Micro Operation Code Assignment Map
 4-257

MASTER
 Master Mode Entry 4-140

MECHANISM
 APPENDING UNIT OPERATION WITH RING
 MECHANISM 8-3

MEMORY
 Associative Memory Assembly 1-4
 Cache Memory Control in Segment
 Descriptor Words 9-6
 Main memory 9-1
 Main Memory Address Generation 5-3,
 5-5
 Main Memory Addresses 4-4
 modes of main memory addressing 1-3
 Page Table Word Associative Memory
 (PTWAM) 3-20
 Privileged - Clear Associative
 Memory 4-168
 Segment Descriptor Word Associative
 Memory (SDWAM) - DPS/L68 and
 DPS 8M 3-18

MICRO
 Micro Operation Code Assignment Map
 4-257

MISCELLANEOUS
 Fixed-Point Miscellaneous 4-69
 Floating-Point Miscellaneous 4-109
 Pointer Register Miscellaneous
 4-135
 Privileged - Miscellaneous 4-176

MNEMONIC
 mnemonic code 4-2

MODE
 Absolute Mode 1-3
 append mode 5-2
 BAR mode 1-4
 Cache Mode Register (CMR) - DPS and
 L68 3-32
 Master Mode Entry 4-140
 Mode Register (MR) - DPS and L68
 3-27
 normal mode 1-3

MODE (cont)
 privileged mode 1-3

MODES
 CHANGING ADDRESSING MODES 5-5
 modes of main memory addressing 1-3

Modification
 Address modification 1-2
 General Computed Address
 Modification Types 6-5
 Indirect Then Register (ir)
 Modification 6-10
 Indirect Then Tally (it)
 Modification 6-12
 INDIRECT TO POINTER (ITP)
 MODIFICATION 6-20
 INDIRECT TO SEGMENT (ITS)
 MODIFICATION 6-21
 modification field 4-9
 Register (r) Modification 6-6
 Register Then Indirect (ri)
 Modification 6-9

MODIFIER
 Address Modifier (TAG) Field 6-3
 illegal modifier 4-6

MODIFIERS
 special address modifiers 6-19

MOVE
 EIS - Alphanumeric Move 4-202
 EIS - Numeric Move 4-213

MOVEMENT
 Fixed-Point Data Movement Load 4-16
 Fixed-Point Data Movement Shift
 4-36
 Fixed-Point Data Movement Store
 4-25
 Floating-Point Data Movement Load
 4-86
 Floating-Point Data Movement Store
 4-87
 Pointer Register Data Movement Load
 4-124
 Pointer Register Data Movement Store
 4-130

MR
 Mode Register (MR) - DPS and L68
 3-27

MULTIPLICATION
 EIS - Decimal Multiplication 4-239
 Fixed-Point Multiplication 4-57
 Floating-Point Multiplication 4-96

MULTIWORD
 EIS multiword instructions 4-2, 4-8

MVE
 MVNE and MVE Differences 4-248

MVNE
 MVNE and MVE Differences 4-248

NEGATE
 Fixed-Point Negate 4-62
 Floating-Point Negate 4-103

NO
 No Operation 4-143

Normal
 Normal mode 1-3

NORMALIZE
 Floating-Point Normalize 4-104

NOT
 Boolean Comparative NOT 4-84

NOTATION
 NOTATION AND SYMBOLS 4-4

NUMBER
 binary number system 2-1
 effective segment number generation 6-22
 Page Number Formation 5-3

NUMERIC
 EIS - Numeric Compare 4-210
 EIS - Numeric Move 4-213
 NUMERIC EDIT 4-248
 NUMERIC OPERAND DESCRIPTOR FORMAT 4-13

OPERAND
 ALPHANUMERIC OPERAND DESCRIPTOR FORMAT 4-12
 BIT-STRING OPERAND DESCRIPTOR FORMAT 4-15
 NUMERIC OPERAND DESCRIPTOR FORMAT 4-13
 OPERAND DESCRIPTOR INDIRECT POINTER FORMAT 4-11.1

OPERATION
 APPENDING UNIT OPERATION WITH RING MECHANISM 8-3
 BOOLEAN OPERATION INSTRUCTIONS 4-70
 Micro Operation Code Assignment Map 4-257
 No Operation 4-143
 Operation Unit 1-5

OPERATIONS
 basic operations 4-1
 extended instruction set (EIS) operations 4-1
 Operations Unit (OU) History Register 3-41

OR
 Boolean EXCLUSIVE OR 4-78
 Boolean OR 4-74

OTHER
 Other Symbols 4-5

OU
 Operations Unit (OU) History Register 3-41

OVERLENGTH
 Overlength Registers 2-8

PAGE
 page frames 1-2
 Page Number Formation 5-3
 Page Table Word (PTW) Format 5-10
 Page Table Word Associative Memory (PTWAM) 3-20

PAGING 5-3
 Segmentation and Paging 1-2

PARITY
 DATA PARITY 2-4

POINTER
 INDIRECT TO POINTER (ITP) MODIFICATION 6-20
 OPERAND DESCRIPTOR INDIRECT POINTER FORMAT 4-11.1
 Pointer Register (PRn) 3-11
 Pointer Register Address Arithmetic 4-134
 Pointer Register Data Movement Load 4-124
 Pointer Register Data Movement Store 4-130
 Pointer Register Miscellaneous 4-135
 Procedure Pointer Register (PPR) 3-14
 Temporary Pointer Register (TPR) 3-15

POINTERS
 indirect pointers 4-11

PPR
 Procedure Pointer Register (PPR) 3-14

PRIORITY
 fault priority groups 7-3

PRIVILEGED
 Privileged - Clear Associative Memory 4-168
 Privileged - Configuration and Status 4-170
 Privileged - Miscellaneous 4-176
 Privileged - Register Store 4-163
 Privileged - System Control 4-173
 privileged mode 1-3

Privileged - Register Load 4-157.1

PRN
 Pointer Register (PRn) 3-11

PROCEDURE
 Procedure Pointer Register (PPR) 3-14

PROCESSOR 1-1
 PROCESSOR FEATURES 1-1

PTW
Page Table Word (PTW) Format 5-10

PTWAM
(PTWAM) registers 1-4
Page Table Word Associative Memory
(PTWAM) 3-20

Q
Quotient Register (Q) 3-3

QUOTIENT
Quotient Register (Q) 3-3

R
Register (r) Modification 6-6

RALR
Ring Alarm Register (RALR) 3-10

REFERENCE
Locality of reference 9-1

REGISTER
(PTWAM) registers 1-4
(SDWAM) registers 1-4
Accumulator Register (A) 3-2
Accumulator-Quotient Register (AQ)
3-3
Address Register (ARn) 3-12
Appending Unit (APU) History
Register - DPS 8M 3-51
Appending Unit (APU) History
Register - DPS and L68 3-49
base address register 1-4
Base Address Register (BAR) 3-9
Cache Mode Register (CMR) - DPS and
L68 3-32
Control Unit (CU) History Register -
DPS 8M 3-39
Control Unit (CU) History Register -
DPS and L68 3-37
Decimal unit history register 3-43
Descriptor Segment Base Register
(DSBR) 3-16
EIS - Address Register Load 4-177
EIS - Address Register Special
Arithmetic 4-183
EIS - Address Register Store 4-180
Exponent Register (E) 3-4
Exponent-Accumulator-Quotient
Register (EAQ) 3-4
Fault Register (FR) - DPS and L68
3-23
Index Register (Xn) 3-5
Indicator Register (IR) 3-5
Indirect Then Register (ir)
Modification 6-10
Mode Register (MR) - DPS and L68
3-27
Operations Unit (OU) History
Register 3-41
Overlength Registers 2-8
Pointer Register (PRn) 3-11
Pointer Register Address Arithmetic
4-134
Pointer Register Data Movement Load
4-124

REGISTER (cont)
Pointer Register Data Movement Store
4-130
Pointer Register Miscellaneous
4-135
Privileged - Register Store 4-163
Procedure Pointer Register (PPR)
3-14
Quotient Register (Q) 3-3
Register (r) Modification 6-6
Register Load 4-157
Register Then Indirect (ri)
Modification 6-9
Ring Alarm Register 4-153
Ring Alarm Register (RALR) 3-10
Store Base Address Register 4-154
Temporary Pointer Register (TPR)
3-15
Timer Register (TR) 3-10

Repeat 4-145

RI
Register Then Indirect (ri)
Modification 6-9

RING
APPENDING UNIT OPERATION WITH RING
MECHANISM 8-3
Ring Alarm Register 4-153
Ring Alarm Register (RALR) 3-10

ROUND
Floating-Point Round 4-105

SDW
Segment Descriptor Word (SDW) Format
5-9

SDWAM
(SDWAM) registers 1-4
Segment Descriptor Word Associative
Memory (SDWAM) - DPS/L68 and
DPS 8M 3-18

SEGMENT
Cache Memory Control in Segment
Descriptor Words 9-6
Descriptor Segment Base Register
(DSBR) 3-16
effective segment number generation
6-22
INDIRECT TO SEGMENT (ITS)
MODIFICATION 6-21
Segment Descriptor Word (SDW) Format
5-9
Segment Descriptor Word Associative
Memory (SDWAM) - DPS/L68 and
DPS 8M 3-18
segment size 1-2

Segment Descriptor Word 8-2

SEGMENTATION 5-2
Segmentation and Paging 1-2

SEQUENCE
FAULT CYCLE SEQUENCE 7-1

SEQUENCES
 Address Appending Sequences 5-6

SET
 EIS - Bit String Set Indicators 4-224
 extended instruction set (EIS) operations 4-1
 VIRTUAL ADDRESS FORMATION FOR EXTENDED INSTRUCTION SET 6-24

SHIFT
 Fixed-Point Data Movement Shift 4-36

SINGLE-WORD
 EIS single-word instructions 4-2, 4-6

SIZE
 segment size 1-2

SPECIAL
 EIS - Address Register Special Arithmetic 4-183
 special address modifiers 6-19

STATUS
 Privileged - Configuration and Status 4-170

STORE
 EIS - Address Register Store 4-180
 Fixed-Point Data Movement Store 4-25
 Floating-Point Data Movement Store 4-87
 Pointer Register Data Movement Store 4-130
 Privileged - Register Store 4-163
 Store Base Address Register 4-154

STRING
 EIS - Bit String Combine 4-218
 EIS - Bit String Compare 4-222
 EIS - Bit String Set Indicators 4-224

SUBTRACTION
 EIS - Decimal Subtraction 4-236
 Fixed-Point Subtraction 4-50
 Floating-Point Subtraction 4-93

SWITCH
 Configuration Switch Data - DPS 8M 3-56
 Configuration Switch Data - DPS and L68 3-54

SYMBOLS
 Abbreviations and Symbols 4-4
 NOTATION AND SYMBOLS 4-4
 Other Symbols 4-5

SYSTEM
 binary number system 2-1
 Privileged - System Control 4-173

TABLE
 edit insertion table 4-246
 Page Table Word (PTW) Format 5-10
 Page Table Word Associative Memory (PTWAM) 3-20

tabs 4-8

TAG
 Address Modifier (TAG) Field 6-3

TALLY
 Indirect Then Tally (it) Modification 6-12

TEMPORARY
 Temporary Pointer Register (TPR) 3-15

THEN
 Indirect Then Register (ir) Modification 6-10
 Indirect Then Tally (it) Modification 6-12
 Register Then Indirect (ri) Modification 6-9

TIMER
 Timer Register (TR) 3-10

TPR
 Temporary Pointer Register (TPR) 3-15

TR
 Timer Register (TR) 3-10

Translation 4-155

TYPES
 General Computed Address Modification Types 6-5

UNIT
 Appending Unit 1-4
 Appending Unit (APU) History Register - DPS 8M 3-51
 Appending Unit (APU) History Register - DPS and L68 3-49
 APPENDING UNIT DATA WORD FORMATS 5-9
 APPENDING UNIT OPERATION WITH RING MECHANISM 8-3
 Control Unit 1-4
 Control Unit (CU) History Register - DPS 8M 3-39
 Control Unit (CU) History Register - DPS and L68 3-37
 Control Unit Data 3-58
 Decimal Unit 1-5
 Decimal Unit Data 3-63
 Decimal unit history register 3-43
 Operation Unit 1-5
 Operations Unit (OU) History Register 3-41

UNSTRUCTURED
 unstructured formats 2-2

VALUES

Index Values 4-4

VIRTUAL

virtual address formation 6-1, 6-19
VIRTUAL ADDRESS FORMATION FOR
EXTENDED INSTRUCTION SET 6-24

WORD

APPENDING UNIT DATA WORD FORMATS
5-9

indirect word 4-8

INSTRUCTION WORD FORMATS 4-6

Page Table Word (PTW) Format 5-10

Page Table Word Associative Memory
(PTWAM) 3-20

Segment Descriptor Word (SDW) Format
5-9

Segment Descriptor Word Associative
Memory (SDWAM) - DPS/L68 and
DPS 8M 3-18

WORDS

Cache Memory Control in Segment
Descriptor Words 9-6

XN

Index Register (Xn) 3-5

Together, we can find the answers.

Honeywell

Honeywell Information Systems

U.S.A.: 200 Smith St., MS 486, Waltham, MA 02154

Canada: 155 Gordon Baker Rd., Willowdale, ON M2H 3N7

U.K.: Great West Rd., Brentford, Middlesex TW8 9DH **Italy:** 32 Via Pirelli, 20124 Milano

Mexico: Avenida Nuevo Leon 250, Mexico 11, D.F. **Japan:** 2-2 Kanda Jimbo-cho Chiyoda-ku, Tokyo

Australia: 124 Walker St., North Sydney, N.S.W. 2060 **S.E. Asia:** Mandarin Plaza, Tsimshatsui East, H.K.

39649, 284, Printed in U.S.A.

AL39-01